



DATE: July 11, 2019

FROM: Wight & Company
2500 N. Frontage Road
Darien, IL 60561

Wight & Company

wightco.com

.....
2500 North Frontage Road
Darien, IL 60561

.....
P 630.969.7000

F 630.969.7979

SUBJECT: **ADDENDUM #1 TO THE BIDDING DOCUMENTS FOR:
NORTH HIGH SCHOOL BID GROUP #7 Phase B Part B**
MASTER FACILITY PLAN IMPLEMENTATION
COMMUNITY HIGH SCHOOL DISTRICT 99
NORTH HIGH SCHOOL
4436 MAIN STREET
DOWNERS GROVE, IL 60516

This addendum forms a part of the Bidding Contract Documents, dated June 7, 2019. Bidders must acknowledge receipt of this Addendum in the space provided on the Bid Form.

Bid Date Change:

Tuesday July 23rd 2019
1:00 pm
6301 Springside Ave
Downers Grove, IL 60516

Scope of work:

00300 BG7B BP55 Drywall & Metal Frames
00300 BG7B BP58 Electrical
00300 BG7B BP59 Kitchen Equipment

I. Clarifications

1. None

II. Specifications

1. Section 114000 Food Service Equipment

III. Drawings

K100-General notes and schedule

K101-Layout & schedule

K102-Special conditions layout

K200-Spot locations and schedules

K600-Exhaust ventilation system drawing, details and schedules

K700- Equipment details, elevations and sections

END OF ADDENDUM

BG7B BP55 SCOPE OF WORK FOR METAL FRAMING & GYPSUM BOARD – NORTH HIGH SCHOOL

Scope – This TRADE CONTRACTOR's scope shall include but not be limited to the scope listed below. Please see entirety of bid documents for all scope requirements.

1. This TRADE CONTRACTOR shall reference ALL General, Structural, Demolition, Architectural and MEP Sheets included in this Bid Group 7B as they relate to Metal Framing and Gypsum Board. This TRADE CONTRACTOR shall read all Notes and General Notes included in the drawings as they pertain to this scope of work. This TRADE CONTRACTOR shall review the project SCHEDULE included in this project manual and provide sufficient manpower to complete this TRADE CONTRACTOR's scope of work within the designated durations provided.
2. This TRADE CONTRACTOR shall be responsible for furnishing and installing all materials, skilled and/or licensed labor, equipment, tools, etc.. to complete all aspects of this TRADE CONTRACTOR's work **Cold Formed Metal Framing, Light Gauge Metal Framing, Gypsum Board Sheathing and accessories, Extruded Metal Corner Reinforcing, Fire-Resistant Assembly Identification, Acoustical Batts, Elevator Shaft Walls, LULA lift shaft walls, Gypsum Board Reveals, Backer Boards, Joint Sealants (as part of the drywall system), Non-hardening Acoustical Sealants, Acoustical Joint Sealants over Butyl Backer Rod and Wool Felt.** All work completed according to the specifications and as shown on the construction documents.

NOTE: This TRADE CONTRACTOR shall be responsible for furnishing and installing abuse resistant gypsum board as called out in construction documents. Refer to drawings A8.00 and A8.01 for further details and instructions.

NOTE: This TRADE CONTRACTOR shall be responsible for furnishing and installing high impact wall stud spacing with high impact high abuse gypsum board as called out per keynote 20 on A2.02B.b.

NOTE: This TRADE CONTRACTOR shall be responsible for ALL framing, exterior sheathing and fluid applied air barrier, insulation, plywood (cover board) for all roof details shown on A5.41 and all similar details.

For all exterior wall type A1, this TRADE CONTRACTOR shall furnish and install

1. A minimum of 20 mil fluid air & water barrier membrane applied to the facer-mat of the glass-mat panel
2. Maximum 10 perm rating on the composite panel and air and water barrier membrane

NOTE: This TRADE CONTRACTOR shall be responsible for furnishing and installing ALL components of Top of Wall details on drawings A8.00 and A8.01, including but not limited to mineral wool, deflection track, acoustical joint sealant spray, etc. Refer to Partition Types on drawings A8.00 and A8.01 for further details and instructions.

NOTE: This TRADE CONTRACTOR shall be responsible for providing tile backer board in lieu of gypsum wood board at partitions receiving wall tile.

NOTE: This TRADE CONTRACTOR shall provide moisture resistant gypsum board at partitions adjacent to plumbing and/ or plumbing fixtures.

NOTE: This TRADE CONTRACTOR shall NOT be responsible for furnishing or installing ceiling or wall joint covers (CJ, WJ). This scope of work will be by the GENERAL CARPENTRY TRADE CONTRACTOR.

3. This TRADE CONTRACTOR shall be responsible for furnishing and installing ALL gypsum board ceilings shown on reflected ceiling plans. Refer to RCPs and ceiling details on A3.10 and A3.11 for further details and instructions. This TRADE CONTRACTOR shall include 20ea. Access panels in their base bid to be located by the CONSTRUCTION MANAGER.
4. This TRADE CONTRACTOR shall NOT be responsible for furnishing Hollow Metal Doors and Frames, Service Windows, Flush Wood Doors, or Door Hardware as shown in the Contract Documents.

NOTE: This TRADE CONTRACTOR shall be responsible for unloading and setting ALL Hollow Metal Doors and Hollow Metal Window Frames in new gypsum board partitions. The abovementioned frames are furnished and delivered by the DOORS & HARDWARE TRADE CONTRACTOR. Glazing of the abovementioned frames is the responsibility of the STOREFRONT TRADE CONTRACTOR.

5. This TRADE CONTRACTOR shall be responsible for the delegated design/ structural engineering of the Cold Formed Metal Framing (CFMF) by a licensed Illinois Structural Engineer per the contract documents.
6. This TRADE CONTRACTOR shall be responsible for and compliant with all specified requirements including but not limited to all: Performance Requirements, Submittals, QA, Testing, Training, QC, and Extra Materials specified and pertaining to this TRADE CONTRACTOR's work as noted in the plans and specifications.

NOTE: This TRADE CONTRACTOR's Guarantee/warranty period of equipment will not start until after final acceptance, including any and all equipment/material utilized before final acceptance.

7. This TRADE CONTRACTOR shall be responsible for wall layout prior to mobilization and installation of this scope of work for use by OTHERS. This may include installing the top track only for coordination with other trades and should figure multiple mobilizations to complete this scope of work per the Project Schedule and at the direction of the CONSTRUCTION MANAGER.
8. This TRADE CONTRACTOR shall be responsible to provide its own project layout according to the drawings, considering the benchmark locations and elevations that will be given by the Construction Manager.

ALLOWANCES, BOND, & ALTERNATES

1. This TRADE CONTRACTOR shall include an allowance of **\$40,000.00 in their base bid** to account for any unforeseen conditions. Contract amounts will be adjusted by change order for amounts greater or less than the allowance. Allowance to be utilized only at the direction of Construction Manager.
2. This TRADE CONTRACTOR will be required to provide a Performance and Payment Bond for their work in accordance with 00201 of the General Conditions.

00300-2

ACCEPTANCE

Accepted as listed above in addition to terms and conditions of the original construction documents on which the bid was based.

Company: Wight Construction Services, Inc.
2500 North Frontage Road
Darien, IL 60561

Signed: _____

Printed Name: _____

Position: _____

Date: _____

END OF SECTION 00300 –Scope

BG7B BP58 SCOPE OF WORK FOR ELECTRICAL – NORTH HIGH SCHOOL

Scope – This TRADE CONTRACTOR’s scope shall include but not be limited to the scope listed below. Please see entirety of bid documents for all scope requirements.

1. This TRADE CONTRACTOR shall reference ALL General, Logistics Plan, Civil, Structural, Architectural, MEP and Kitchen & Seryery drawings in this Bid Group 7B as they relate to Electrical. This TRADE CONTRACTOR shall read all Specification Sections in this manual as well as Notes and General Notes included in the drawings as they pertain to this scope of work. This TRADE CONTRACTOR shall review the project SCHEDULE included in this project manual and provide sufficient manpower and equipment to complete this TRADE CONTRACTOR’s scope of work within the designated durations provided.
2. This TRADE CONTRACTOR acknowledges there is an occupied portion of the building that will remain occupied throughout the duration of this project. Existing Life Safety systems must remain protected and in-service.
3. This TRADE CONTRACTOR shall be responsible for furnishing and installing all materials, skilled and/or licensed labor, equipment, tools, etc. to complete all aspects of this trade contractor’s work for the complete electrical package including but not limited to **power, temporary power, grounding & bonding, panels, outlets, floor boxes, interior lighting, occupancy sensors, exterior lighting, site lighting, emergency lighting, exit lighting, temporary lighting, lighting controls, automatic lighting controls, transformer(s), surge protection, disconnects, miscellaneous equipment/motor wiring, etc...** all work as listed in the specifications and shown on the construction documents.

NOTE: This TRADE CONTRACTOR shall furnish and install all raceways, power, backboxes, and stub-ups per Kitchen (K-series) drawings.

NOTE: This TRADE CONTRACTOR shall coordinate all equipment types, connection types, plug types, and circuit requirements with the Kitchen Drawings. This TRADE CONTRACTOR shall coordinate, furnish and install ALL final electrical hookups, disconnects, etc. Refer to Kitchen Equipment Schedules on E7.03 for further details.

NOTE: This TRADE CONTRACTOR IS **NOT** responsible for the telecommunications, A/V, temperature control, and Security raceways, pathways, pull boxes, junction boxes, and pull points as noted on the drawings. The Low-Voltage contractor will be responsible to provide their own rough-in.

NOTE: This TRADE CONTRACTOR shall **NOT** be responsible for fire stopping all thru wall penetrations in rated walls as indicated on construction documents and/or as specified in the project manual. This work is to be completed by the **GENERAL CARPENTRY BID PACKAGE.**

4. This TRADE CONTRACTOR shall review and become familiar with ALL documents included in this bid group. This Trade Contractor shall furnish, install, complete and/or otherwise comply with all work as noted and or implied by the following but not limited to: All Specification sections in Divisions 26, General Notes, and all sheets under the Electrical Scope.

Note: All Demolition work shown on the demolition drawings will be completed by OTHERS. THIS TRADE CONTRACTOR shall be responsible to verify all demolition work and make safe any connections and remove wiring back to existing panels. **This TRADE CONTRACTOR, shall mobilize prior to demolition activities to assist in**

marking existing piping, panels, equipment, etc., to remain for coordination with the DEMOLITION CONTRACTOR and CONSTRUCTION MANAGER.

Note: This TRADE CONTRACTOR shall be responsible for Primary Service Riser demolition including all underground wiring, panels, ATS, transformers, conduits, disconnects, and switchgear as shown on sheet E5.00 and ED2.01B. The underground raceways will be cut & capped below grade and abandoned in place.

5. This TRADE CONTRACTOR shall be responsible to intercept existing raceways to remain that will be re-fed from new panel locations. All junction boxes, splices, accessories, and any new wiring is to be included. Pull box locations and new or existing raceways associated with this work shall be identified on building as-builts. This also applies to the existing emergency generator system.
6. This TRADE CONTRACTOR is responsible for shop drawings, layout, and field layout of conduits, boxes, hangers, fixtures, etc...

Note: This TRADE CONTRACTOR acknowledges that this contractor shall coordinate conduit layout in a neat and orderly fashion. This Trade Contractor further acknowledges that the design team will have some input on location and routing of exposed raceways.

7. This TRADE CONTRACTOR is responsible for shop drawings, layout, and field layout of this TRADE CONTRACTOR's work. This TRADE CONTRACTOR shall coordinate the installation of his work with plumbing, electrical, HVAC, technology, ceiling and all other trades as required. Mechanical contractor shall lead in the coordination effort of all of these trades. This shall include obtaining the Autocad files from the sprinkler, plumbing and electrical contractor and plotting all systems in color on one drawing.
8. This TRADE CONTRACTOR shall be responsible for furnishing, layout, and installation of all electrical components including but not limited to: conduit, boxes, wiring, light fixtures, lamps, exit signs, panels, transformer(s), switchgear, outlets, switches, plates, etc... and any other electrical/lighting components as required within the specifications and as indicated on drawings. This TRADE CONTRACTOR shall be responsible for all conduit, pull string and junction boxes as required within the specifications and as indicated on drawings.
9. This TRADE CONTRACTOR shall be responsible for all electrical requirements for electric door strikes, power transfer supplies, locks and other hardware as indicated on the architectural door schedule whether shown on the Electrical plans or not. Hardware by OTHERS. This TRADE CONTRACTOR is also responsible for the final connections of these components for a complete install.
10. This TRADE CONTRACTOR shall be responsible for installing ALL Light Fixtures supported independent from ceiling grid.
11. This TRADE CONTRACTOR shall be responsible for coordination with other trade contractors to obtain wiring diagrams and power requirements for equipment furnished by OTHERS, prior to wiring same in the field.
12. This TRADE CONTRACTOR is responsible for any necessary electrical required for all mechanical equipment as required within the specifications and indicated on drawings.
13. This TRADE CONTRACTOR shall be responsible for all directory label charts, along with identification and tagging requirements of work as required within the specifications and as indicated on the drawings, per Construction Manager direction (verify numbering and tagging sequence with Construction Manager). Contractor shall provide a typed directory

00300-2

in every panel matching the As-Built condition and not necessarily as shown in the panel schedules.

14. This TRADE CONTRACTOR shall be responsible for all electrical/lighting related work on drawings and in specifications, as may be noted on architectural, mechanical, Fire Protection, Plumbing and Kitchen (K-series) drawings, documents or specification sections.
15. Regardless of fixture designation, i.e. grid type, flange type, lay-in as may be designated on the drawings, this TRADE CONTRACTOR will correlate with the reflected ceiling plan and will furnish the fixture to fit the ceiling construction as outlined in the reflected ceiling drawings and/or room finish schedule.
16. This TRADE CONTRACTOR shall be responsible for all hand or machine excavation, backfill, compaction, and concrete as required to install this Trade Contractor's work, including granular fill requirements for any under slab or sitework as required within the specifications and indicated on drawings.

NOTE: Any saw-cutting of existing concrete slabs for installation of any materials related to this scope of work is the responsibility of this TRADE CONTRACTOR. i.e. floor boxes raceways, etc.. The subsequent backfill and concrete patching is the responsibility of this TRADE CONTRACTOR.

- ~~17. All New Primary & Medium Voltage raceways underground as indicated on E1.00 shall be backfilled and 4" of concrete poured over top of raceways for protection. Metallic tape with "DANGER HIGH VOLTAGE" shall be laid on top of trench prior to final backfill. All of this work including rough grading and any existing pavement patching is the responsibility of this TRADE CONTRACTOR.~~

~~**NOTE:** Any dewatering of existing vaults/manholes in order for this TRADE CONTRACTOR to do their work is the responsibility of THIS TRADE CONTRACTOR.~~

18. This TRADE CONTRACTOR shall be responsible for testing of electrical/lighting systems as required in obtaining approval of inspection authorities having jurisdiction
19. This TRADE CONTRACTOR shall be responsible for all electrical connections, including low-voltage, for all starters, motor control devices, installation of VFD's, etc... for HVAC, Controls, Fire Protection and plumbing work as required within the specifications and as indicated on drawings.

- ~~20. This TRADE CONTRACTOR shall provide layout, frame and pour concrete interior housekeeping pads needed for equipment furnished and installed by this TRADE CONTRACTOR.~~

~~**Note:** This TRADE CONTRACTOR shall furnish and install the concrete pads for the exterior transformers as shown on the Electrical Site Plan E1.0.~~

21. This TRADE CONTRACTOR shall include connections of any related equipment furnished by others (i.e. hot water heater(s), electric water cooler, HVAC equipment, etc...) as shown on the drawings.

- ~~22. This TRADE CONTRACTOR shall be responsible for the coordination with electrical utility companies for the procurement and installation of the new power (i.e. Transformer, CT Meter and Cabinet, any and all associated assemblies, pads, grounding installations, trenching, sleeves, future pull strings, etc...) and/or hardware necessary for a complete and functioning service.~~

00300-3

Note: Work specified for Utility Companies shall be as coordinated with Electrical Contractor and paid for by CONSTRUCTION MANAGER (IF ANY).

23. This TRADE CONTRACTOR shall be responsible for furnishing, installing and maintaining all temporary electrical service and lighting as required by CONSTRUCTION MANAGER, per OSHA standards, in all areas of construction.

NOTE: Installation of temporary lighting must be installed prior to demolition activities and a separate mobilization shall be figured. Coordinate with CONSTRUCTION MANAGER.

24. This TRADE CONTRACTOR shall be responsible for and compliant with all specified requirements including but not limited to all: Performance Requirements, Submittals, QA, Testing, Training, QC, and Extra Materials specified and pertaining to this trade contractor's work as noted in the plans and specifications.

Note: This TRADE CONTRACTOR's Guarantee/warranty period of equipment will not start until after final acceptance, including any and all equipment utilized before final acceptance.

25. This TRADE CONTRACTOR shall be NOT be responsible for fire stopping all thru wall penetrations in rated walls as indicated on construction documents and/or as specified in the project manual. This work is by OTHERS. This TRADE CONTRACTOR shall provide all clip hangers, angles, and miscellaneous metal of any nature, which is required for work covered by this Contract.

26. This TRADE CONTRACTOR shall coordinate all piping to avoid conflicts with areas required for other trade contractor's work (i.e., F.P. piping, F.P. heads, ductwork, etc...).

ALLOWANCES, BOND, & ALTERNATES

1. This TRADE CONTRACTOR shall include an allowance of **\$40,000.00 in their base bid** to account for any unforeseen conditions. Contract amounts will be adjusted by change order for amounts greater or less than the allowance. Allowance to be utilized only at the direction of Construction Manager.
2. This TRADE CONTRACTOR will be required to provide a Performance and Payment Bond for their work in accordance with 00201 of the General Conditions.
3. **Alt. Bid #1:** This TRADE CONTRACTOR shall provide an ADD alternate to furnish and install lighting fixtures in Area E.

ACCEPTANCE

Accepted as listed above in addition to terms and conditions of the original construction documents on which the bid was based.

00300-4

Company: Wight Construction Services, Inc.
2500 North Frontage Road
Darien, IL 60561

Signed: _____
Printed Name: _____
Position: _____
Date: _____

END OF SECTION 00300 –Scope

Scope – This TRADE CONTRACTOR’s scope shall include but not be limited to the scope listed below. Please see entirety of bid documents for all scope requirements.

BG7B BP59 SCOPE OF WORK KITCHEN EQUIPMENT – NORTH AND SOUTH HIGH SCHOOL

1. This TRADE CONTRACTOR shall reference ALL General, Logistics Plan, Architectural, MEP and Kitchen Service Sheets included in this Bid Group 7B as they relate to Kitchen Equipment. This TRADE CONTRACTOR shall read all Specification Sections in this manual as well as Notes and General Notes included in the drawings as they pertain to this scope of work. This TRADE CONTRACTOR shall review the project SCHEDULE included in this project manual and provide sufficient manpower and equipment to complete this trade contractor’s scope of work within the designated durations provided.
2. This TRADE CONTRACTOR shall be responsible for furnishing and installing all materials, equipment, skilled and/or licensed labor, tools, etc... to complete all aspects of this TRADE CONTRACTOR’s work for Kitchen Equipment as listed in the specifications and Kitchen & Served drawings (K-series). This TRADE CONTRACTOR shall be responsible for furnishing and installing ALL equipment listed in the Equipment Schedule in Kitchen & Served drawings and Kitchen Equipment specifications 114000, except for items that are explicitly marked “NOT IN KEC CONTRACT.”

NOTE: This TRADE CONTRACTOR is responsible for the Kitchen Equipment as specified in Food Service Equipment Specifications, 114000. This TRADE CONTRACTOR shall follow all requirements listed in the specifications.

3. This TRADE CONTRACTOR shall be responsible for any and all associated hardware, accessories, controls, etc... as needed for a complete installation.

NOTE: Final connections for power, ventilation, plumbing, etc...shall be by that respective TRADE CONTRACTOR but this TRADE CONTRACTOR shall coordinate and provide all required Product Data as necessary.

4. This TRADE CONTRACTOR shall leave the site in a safe and orderly manner including barricades and effective deterrents from any and all possible dangers on a daily basis and at the conclusion of this TRADE CONTRACTOR’s work.
5. This TRADE CONTRACTOR shall be responsible to provide its own project layout according to the drawings, considering the benchmark locations and elevations that will be given by the Construction Manager.
6. This TRADE CONTRACTOR shall provide, on a separate form to be submitted with bid documents, a quantity take-off and cost breakdown of this bid.

SITE SPECIFIC – DOWNERS GROVE SOUTH

00300-1

1. This TRADE CONTRACTOR shall be responsible for furnishing and installing all materials, equipment, skilled and/or licensed labor, tools, etc... to complete all aspects of this TRADE CONTRACTOR’s work for Kitchen Equipment as listed in the specifications and Kitchen & Servery drawings (K-series). This TRADE CONTRACTOR shall be responsible for furnishing and installing ALL equipment listed in the Equipment Schedule in Kitchen & Servery drawings and Kitchen Equipment specifications 114000, except for items that are explicitly marked “NOT IN KEC CONTRACT.”

NOTE: This TRADE CONTRACTOR is responsible for the Kitchen Equipment as specified in Food Service Equipment Specifications, 114000. This TRADE CONTRACTOR shall follow all requirements listed in the specifications.

ALLOWANCES, BOND, AND ALTERNATES

1. This TRADE CONTRACTOR shall include an allowance of **\$10,000.00 in their base bid** to account for any unforeseen conditions. Contract amounts will be adjusted by change order for amounts greater or less than the allowance. Allowance to be utilized only at the direction of Construction Manager.
2. This TRADE CONTRACTOR will be required to provide a Performance and Payment Bond for their work in accordance with 00201 of the General Conditions.

ACCEPTANCE

Accepted as listed above in addition to terms and conditions of the original construction documents on which the bid was based.

Company: Wight Construction Services, Inc.
2500 North Frontage Road
Darien, IL 60561

Signed: _____
Printed Name: _____
Position: _____
Date: _____

END OF SECTION 00300 –Scope

SECTION 114000 – FOODSERVICE EQUIPMENT

PART 1 - GENERAL

1.01 DESCRIPTION OF WORK

- A. The Food Facility Consultant (FFC) for this project is Reitano Design Group. In the event it is necessary to communicate questions, clarifications and comments, from prior to bid award through final purchase, contact the FFC at the following:

Reitano Design Group
302 North East Street, Studio One
Indianapolis, Indiana 46202
Phone: 317-637-3204

- B. Kitchen Equipment Contractor (KEC) means the company or corporation who will contract completion of work specified herein.

1.02 RELATED DIVISIONS / WORK BY OTHER TRADES

- A. Refer to General Conditions, Supplementary Conditions, and applicable provisions of Division 1 for additional instructions.
- B. Refer to Mechanical/Plumbing Divisions for applicable provisions and sections regarding mechanical services necessary to complete final connections to individual items as specified in this section. This work to include, but not be limited to, the following:
1. Rough-in all required services for all equipment specified and shown on drawings.
 2. Furnish and install all piping, traps, tailpieces, vents, stops, valves and other related items necessary for final connections.
 3. Install all items provided loose by the KEC per specifications such as, but not limited to, faucets, vacuum breakers, solenoid valves and control panels.
 4. Final mechanical and ventilating connections to equipment.
- C. Refer to Electrical Divisions for applicable provisions and sections regarding electrical services necessary to complete final connections to individual items as specified in this section. This work to include, but not be limited to, the following:
1. Rough-in all required services for all equipment specified and shown on drawings.
 2. Furnish and install all disconnects, conduit, wire, cover plates, starters, cord sets and other related items necessary for final connections.
 3. Install all items provided loose by the KEC per specifications such as, but not limited to, control panels, starters and disconnects.
 4. Final electrical connections to equipment.
 5. Furnish and install all control wiring and/or power wiring between electrical components as specified such as, but not limited to, exhaust/make-up air fans and the ventilation hood control panel, walk-in cooler/freezer coils and their respective compressors and the walk-in cooler/freezer lights.

- D. Work included in other Divisions – provision of all wall, floor, and/or ceiling/roof openings, recesses, sleeves, and/or conduits; and equipment pads, and sealing thereof, as necessary for installation of items included in this section.
- E. Work included in other Divisions – disconnection of existing equipment to be relocated and/or reused; and removal of existing equipment which will not be reused, as determined and designated by the Architect in other divisions. (Applicable to project with existing equipment.)
- F. Work referenced by other trades is not for the purpose of assigning work to a specified trade, but rather to clarify the coordination between the KEC and all other trades. All assignments of work by others are to be directed by Division 1 of the written specifications.

1.03 DEFINITIONS

- A. Furnish – supply and deliver to project site, ready for unloading, unpacking, assembly, installation, and similar operations.
- B. Install (set in place) – operations at project site including actual unloading, unpacking, assembly, erecting, placing, anchoring, applying, finishing, curing, protecting, cleaning and similar operations; ready for final utility connections by other divisions as appropriate.
- C. Provide – furnish and install complete, ready for intended use.

1.04 ABBREVIATIONS

- A. FFC – Food Facility Consultant
- B. KEC – Kitchen Equipment Contractor
- C. GD – General Division
- D. ED – Electrical Division
- E. MD – Mechanical Division

1.05 LAWS, ORDINANCES, REGULATIONS AND STANDARDS

- A. Comply with the following;
 - 1. Air Conditioning and Refrigeration Institute (A.R.I.): applicable regulations and references of the latest edition of standards for remote refrigeration system(s), components and installation.
 - 2. American Gas Association (A.G.A.): standards for gas heated equipment, and provide equipment with the A.G.A. seal. Automatic safety pilots to be provided on all equipment, where available. (Canada Gas Association or alternate testing lab's seals accepted if acceptable to local code jurisdictions.)
 - 3. American National Standards Institute (A.N.S.I.): Z21-Series for gas-burning equipment. Provide labels indicating name and testing agency.
 - 4. American National Standards Institute (A.N.S.I.): B57.1 for compressed gas cylinder connections, and with applicable standards of the Compressed Gas Association for compressed gas piping.
 - 5. American National Standards Institute (A.N.S.I.): A40.4 and A40.6 for water connection air gaps and vacuum breakers.
 - 6. American Society of Heating, Refrigeration and Air Conditioning Engineers (A.S.H.R.A.E.): applicable regulations and references of the latest edition of standards for remote refrigeration system(s), components and installation.

7. American Society of Mechanical Engineers (A.S.M.E.): Boiler Code requirements for steam generating and steam heated equipment, and provide A.S.M.E. inspection stamp and registration with National Board.
8. American Society for Testing and Materials (A.S.T.M.): C1036 for flat glass.
9. American Society for Testing and Materials (A.S.T.M.): C1048 for heat-treated flat glass – Kind HS, Kind FT coated and uncoated glass.
10. American Society for Testing and Materials (A.S.T.M.): F232-03 for pre-rinse spray units, and in compliance with Energy Policy Act of 2005 (EPAAct).
11. American Welding Society (A.W.S.): D1.1 structural welding code.
12. Energy Policy Act of 2005 (EPAAct 2005): water savings pre-rinse spray valves.
13. National Electric Code (N.E.C.); N.F.P.A. Volume 5 for electrical wiring and devices included with foodservice equipment, A.N.S.I. C2 and C73, and applicable N.E.M.A. and N.E.C.A. standards.
14. National Electrical Manufacturers Association (N.E.M.A.): LD3 for high-pressure decorative laminates.
15. National Fire Protection Association (N.F.P.A.): applicable sections for exhaust hoods, ventilators, duct and fan materials, hoods fire suppression systems, wheel placement systems, construction and installation; in addition to local codes and standards.
16. National Sanitation Foundation (NSF): latest Standards and Revisions, and as accredited by ANSI, IAS, NELAC, ISO, OSHA and SCC. Provide NSF Seal of Approval on all standard manufactured items included in this project and listed in any NSF Certified Food Equipment Products Category, and on all items of custom fabricated work included in this project. (UL Sanitation approval and seal accepted if acceptable to local code jurisdictions).
17. Sheet Metal and Air Conditioning Contractor's National Association (S.M.A.C.N.A.): latest edition of guidelines for seismic restraint of kitchen equipment, as applicable to project location.
18. Underwriters Laboratories (U.L.): as applicable for electrical components and assemblies. Provide either U.L. labeled products or, where no labeling service is available, "recognized markings" to indicate listing in the U.L. "Recognized Component Index". (Canadian Standards Association or alternate testing lab's seals accepted if acceptable to local code jurisdictions.)
19. UL 300 Standard: for wet chemical fire suppression systems for exhaust hoods/ventilators.
20. American with Disabilities Act (ADA): as applicable to this project.
21. Refrigeration Service Engineers Society (R.S.E.S.): applicable regulations and references of the latest edition of standards for remote refrigeration system(s), components and installation.
22. All refrigerants used for any purpose is to comply with the 1995 and 2010 requirements of the Montreal Protocol Agreement, and subsequent revisions and amendments. No CFC or HCFC refrigerants will be permitted on this project.
23. All refrigeration components installation, repairs, and/or associated work on any refrigeration system, is to be performed by a Certified Refrigeration Mechanic thoroughly familiar with this type commercial foodservice installation.
24. ETL and other national and international recognized Testing and Listing Agencies labels and certifications are acceptable in lieu of Listing Agencies indicated in these documents, if acceptable to the local code jurisdictions.
25. All applicable local codes, standards and regulations.

26. All special local codes, standard, and regulations; such as (examples only) California Energy Commissions Regulations, Dade County requirements for walk-in cooler(s) and/or freezer(s).
27. For detention facilities projects (as applicable): applicable Correctional Standards. Verify the level of security and construction required with the Architect, and provide all items in compliance.

1.06 BIDDING

- A. This specification and the accompanying contract drawings must be considered together. Any work called for in one or on the other, together with such work as can reasonably be considered a part of the installation and necessary to complete same, shall be included.
- B. KEC is responsible for verifying and coordinating all items provided in this section, with the drawings, specifications, manufacturer's requirements, submittals, actual site conditions, adjacent items, and associated (Sub-) Contractors; to assure that there are no discrepancies or conflicts. This is to include, but not be limited to, quantities, dimensions, clearances required, direction of operation, door swings, utilities, fabrication details and methods, installation requirements, etc.
- C. The submitting of a bid shall constitute full evidence that the KEC has viewed and examined the site and all contract documents necessary pertaining to same and that the KEC is therefore, fully cognizant of the conditions under which the work must be conducted.
- D. Where discrepancies are discovered between the drawings and the specifications, regarding quality or quantity, the higher quality or the greater quantity is to be included in the Bid Proposal. KEC to notify the Architect and FFC, in writing, of any discrepancies discovered; and await written clarification prior to proceeding with the items or areas in question.
- E. Unless otherwise instructed by Division 1 bidding instructions, the Bidder shall provide pricing, listing quantity, manufacturer and model number on the attached unit price form with separate total prices for delivery and installation. Any and all city, state, occupational and government taxes, which are applicable to this project, shall be included and added as a separate charge. KEC shall be bound to supply the manufacturer and model number listed on their bid form. Bids shall be valid for thirty (30) days after bid deadline date, and shall indicate same. Failure to comply with the above may be cause for rejection of the bid. Owner reserves the right to delete any item from the bid form.

1.07 APPROVED SUBSTITUTIONS AND/OR LISTED ALTERNATES

- A. The basis of design for all drawings, specifications, and detail references is the first manufacturer and model listed. If another listed manufacturer is chosen by the KEC, it is the responsibility of the KEC to provide a model that is equal in production capabilities, capacity, and performance to the first manufacturer and model listed. The KEC is also to verify, coordinate, and allow for proper installation of equipment; taking into account possible revisions for utility connections, loads, and physical sizes. In the event there are any additional costs or change orders by other trades as a result of the KEC submitting another listed manufacturer, those charges shall be the sole responsibility of the KEC.

- B. The successful contractor will be bound to furnish equipment in strict accordance with the specifications. Where a single manufacturer is listed, it is not the intention to discriminate against any equal product of another manufacturer, but is intended that a definite stringent standard be established.
- C. Any request for substitution of a manufacturer not listed in the specifications shall be submitted at least ten (10) business days prior to the bid opening. Requests are required to be submitted in writing to the Architect with an additional copy sent to the FFC for review. The request shall include complete information with the manufacturer's name, model number, utility information, and all other appropriate data. If approved, the Architect will issue an addendum to all bidders of record.
- D. Should a request for substitution be accepted and the substitute item proves to be defective or otherwise unsatisfactory for the service intended, the KEC shall replace the item with the product that was originally specified. This shall be done within the guarantee period and with no cost to the Owner.
- E. Substitution of non-approved items on the base bid may constitute grounds for rejection of bid.

1.08 SUBMITTALS

- A. General Note: KEC to submit rough-in drawings, equipment brochure books, and manufacturers shop drawings at one time. The submittals will be reviewed as a complete package.
- B. Provide all submittals for review by the FFC per one of the following options:
 - 1. Electronic Format: FFC will print one (1) hardcopy for their records and will return reviewed submittals electronically through the proper channels.
 - 2. Hardcopy Format: KEC to submit five (5) sets of submittals and FFC will keep one (1) set for their records and will return the balance of the reviewed submittals through the proper channels.
- C. KEC to review all submittals for compliance with the Contract Documents prior to submitting to the FFC for review.
- D. Equipment Plan and Rough-In Drawings:
 - 1. Submit 1/2" scale drawings. These drawings are to include complete information on the work included in this contract, with references to equipment as provided by others; and are to provide sufficient information for associated trades, contractors, and/or sub-contractors to complete their division of work associated with food service equipment included in this contract. They are to be dimensioned; showing locations of ducts, stubs, floor and wall sleeves, for ventilation, plumbing, steam, electrical, refrigeration lines, and concrete base and curb dimensions, as required for equipment so supported, and any additional information pertinent to the installation of this equipment.
 - 2. Drawings to also include equipment plan(s) with detailed equipment list, similar to Foodservice Equipment Plans included in the Contract Documents. Item numbers are to be the same as shown in the contract documents, and are to include spare numbers and associated items as provided by others.
- E. Product Data Submittal Manuals:
 - 1. Equipment brochure books shall be provided in a 3-ring binder or GBC bound and shall include the KEC's name, address, phone number, e-mail address, project name and location.
 - 2. Each project item shall be referenced and accounted for in the equipment brochure book regardless of utility requirements and supplier, and shall include:
 - a. Manufacturers catalog sheet

- b. Line drawings as available
- c. Plumbing and/or wiring schematics as available
- d. Data/cover sheet showing:
 - (1) Item number
 - (2) Manufacturer
 - (3) Model number
 - (4) All plumbing information
 - (5) All electrical information
 - (6) All ventilating information
 - (7) All accessories.
3. All refrigerated devices shall include:
 - a. Data sheet showing:
 - (1) BTUH
 - (2) Type of refrigerant
 - (3) Amount of charge
- F. Shop Drawings:
 1. Submit shop drawings for items of custom fabrication included in this contract. Shop drawings are to be submitted at $\frac{3}{4}$ " and/or 1-1/2" scale and are to show dimensions, materials, details of construction, installation and relation of adjoining work requiring cutting or close fitting. Shop drawings are to also indicate reinforcements, anchorage and related work required for the complete installation of fixtures.
 2. Submit shop drawings for any equipment requiring field assembly, including but not limited to, cooking suite assemblies, pulper/extractor assemblies, remote refrigeration systems, walk-in coolers and/or freezers, exhaust hoods/ventilators, fire suppression system, utility distribution systems, pot/utility/ware washing assemblies/machines and conveyors.
 3. Before proceeding with the fabrication or manufacture of any item, KEC is responsible for verifying and coordinating all dimensions and details, with site dimensions, conditions, and adjacent equipment.
- G. FFC's review of submittal drawings, shop details, product data brochures, and operation and maintenance manuals is for general conformance with the design concept and contract documents. Review markings or comments are not to be construed as relieving the KEC from compliance with the contract documents, or departures there from. The KEC remains responsible for details and accuracy, confirming and correlating all quantities and dimensions, selecting fabrication processes, techniques of assembly, and performing their work in a safe, satisfactory, and professional manner.
- H. Commencement of purchasing or fabrication by the KEC, of any item(s) included in this contract, prior to receipt of reviewed submittals from the FFS, shall be at the KEC's own risk; unless specifically instructed to do so in writing by the Owner, including the specific item numbers requested.

1.09 OPERATION & MAINTENANCE DATA MANUALS

- A. Three (3) bound sets of manuals are to be furnished for items of standard manufacture on/or before the date of the first event to occur of the following: demo/start-up, start-up for intended use by the Owner/Operator, completion of installation of kitchen equipment contract package, or final acceptance of installation by Owner. Manuals are to be in alphabetical order according to manufacturer and are to include each individual piece of equipment's serial number as applicable. Manufacturer's info is to

include Technical Services telephone number, e-mail, and web site address, where available.

- B. Provide a complete list of authorized local service agencies for included manufacturers, complete with address, telephone number, e-mail and web site addresses, where available. List to include warranty information per each piece of equipment.
- C. Provide video tapes and/or CD's for maintenance, training, operation, etc., where available from the manufacturer.

1.10 AS-BUILT / RECORD DOCUMENTS (WHEN APPLICABLE TO PROJECT)

- A. Maintain one (1) record set of Foodservice Equipment plans with any related corrections, revisions, additions, deletions, changes, etc. noted during construction and installation. Provide an "as-built" set in reproducible transparency form and electronic computer disk form.
- B. Provide one (1) final set of Product Data Submittal Manual with any related corrections, revisions, additions, deletions, changes, etc. noted during construction and installation as a specifications record set.
- C. These documents are to be provided at the same time as the O&M Data Manuals.

1.11 PRODUCT HANDLING

- A. Deliver materials (except bulk materials) in manufacturer's containers, fully identified with manufacturer's name, trade name, type, class, grade, size, color, item number, area, etc.
- B. KEC is responsible for receiving and warehousing equipment and fixtures, until ready for installation. Store materials, equipment and fixtures in sealed containers, where possible. Store off the ground and under cover, protected from damage.
- C. KEC to verify and coordinate conditions at the building site, particularly door and/or wall openings, and passages, to assure access for all equipment. Pieces too bulky for existing facilities are to be hoisted or otherwise handled with apparatus as required. All special handling equipment charges will be arranged for and paid for by the KEC.

1.12 PRODUCT PROTECTION

- A. To the best of their abilities, KEC is to protect their equipment against theft or damage, until final acceptance by the Owner.
- B. Use all means reasonable to protect the materials of this section before, during, and after installation; and to protect the associated work and materials of the other trades.
- C. Pre-fabricated walk-in coolers/freezers are not to be used as general storage; and should be locked before leaving the site daily. Damage and theft resulting from failure to secure units will be repaired or replaced at the KEC's expense.
- D. No architectural walls, ceilings, décor, structural components or any other details may be physically attached to, into, or rest on any walk-in wall, ceiling panel(s), or component thereof. KEC is responsible for coordinating this requirement with other Contractors.

1.13 WARRANTY

- A. Unless otherwise noted in Related Divisions / Work by Other Trades (Section 1.02), items furnished are to be fully guaranteed against defects in workmanship, materials, and functionality for one (1) full year from the first full day of operation for the food service facility.
 - 1. Date of regular operation is defined as the first full day of operation for this food service facility.
 - 2. Full warranty shall cover all parts, labor, and travel expenses.
 - 3. There shall be no cost to the Owner on matters that are “under warranty”.
 - 4. Manufacturer warranties that extend longer than one (1) year shall be started on the date of regular operation and extend for the full term as prescribed by their specific warranty policy.
- B. Additional Refrigeration Warranty: in addition to one-year warranty requirements as stated above, provide start-up and parts and labor for the first year; plus additional four-year extended warranty on compressors. Extended warranty is for provision of replacement compressor, determined to be defective by a certified refrigeration mechanic. However verification of defective compressor, installation of replacement compressor, recharging and repairs of system will be the responsibility of the Owner. This includes all items with built-in or remote refrigeration system.
- C. Periodic routine maintenance, servicing, adjustments, cleaning, etc., as required by the manufacturers included in this project, are the responsibility of the Owner.
- D. Any and all parts or requirements for manufacturer’s warranties to be in effect, whether or not noted in the itemized specifications, are to be provided or complied with by the KEC. This is to include, but not be limited to, particular parts, accessories, or installation; installation supervision, start-up, and/or follow-up inspections required by factory trained certified, and/or authorized personnel. Factory training, certification, and/or authorization are to be in effect at the time of bidding, installation, start-up, and warranty period of this project.
- E. Manufacturer’s warranties which comply with the requirements of this warranty article 1.13 are to be provided in lieu of KEC’s own warranties, where available. Copies of the written warranties are to be included in the O&M Manuals.
- F. The KEC shall be the Owner’s only contact for any service on any equipment under warranty.
- G. Owner shall have use of defective item until the KEC can deliver and install a replacement.

PART 2 - PRODUCTS

2.01 MATERIALS

- A. Metals:
 - 1. Stainless steel shall be type 304/302, extra low carbon, nonmagnetic, austenitic, corrosion-resisting alloy steel. Composition to be minimum of 18% chromium, minimum 8% nickel and maximum 0.2% carbon. Mill finish of not less than 150 grit on one side and not less than 80 grit on the backside. All stainless steel sheets shall bear manufacturer trademark, designation of type and heat number and shall be stretcher leveled.
 - 2. Galvanized iron shall be an approved grade of either low carbon steel or copper bearing steel. Zinc coating shall be applied after fabrication (brake or die forming, drilling, fitting, welding or other operations). Finish of galvanized iron to be two

- coats of epoxy based gray hammer tone paint on prime undercoat over thoroughly cleaned surfaces.
3. All gauges for sheet iron and sheet steel shall be U.S. standard gauges and shall not vary from standard thickness by more than 5%.
- B. Plastic Laminate: NEMA LD3, Type 2, 0.050" thick, except Type 3, 0.042" for post-forming smooth (non-textured). Color and texture as selected by Architect/Interior Designer and/or Owner.
1. Comply with N.S.F. Standard No. 35.
 2. Veneered with approved waterproof and heat proof cement. Rubber base adhesives are no acceptable.
 3. Applied directly over close grained plywood, such as solid Mahogany or solid Birch, of selected, smooth, sanded stock to ensure a smooth ripple-free laminated surface; or commercial grade furniture particle board, Cortron or equal.
 4. Exposed faces and edges are to be faced with 1/16" thick material. Corresponding backs are to be covered with approved backing and balancing sheet material.
- C. Millwork: No unfinished millwork, plywood/particle board or wood framing (including backs, undersides, and all surfaces concealed from view) will be permitted. All unfinished surfaces or openings cut through finished surfaces are to be sealed to be water resistant; with excess plastic laminate material, Cortron (Melamine) material, backing materials, sealers, primers, finish paint, etc., to blend with specified finish materials.
- D. Hardwood Work Surfaces: Laminated edge grained hard maple (*Acer saccharum*), NHLA First Grade with knots, holes and other blemishes culled out, kiln dried at 8 percent or less moisture, waterproof glue, machined, sanded, and finished with N.S.F. approved oil-sealer.
- E. Solid Surface Material (SSM): As indicated, provide DuPont Corian ½" thick 100% homogeneous filled acrylic material meeting ANSI Z124.6 Type 6; or DuPont Zodiaq ¾" thick quartz material, unless otherwise specified or selected. Colors and patterns as selected by Architect/Interior Designer and/or Owner. The following guidelines and general requirements apply to DuPont SSM, in addition to granite, marble, or any other solid surface materials specified or selected; except fabricator and installer are to be thoroughly experienced and certified in commercial foodservice installation of granite, marble, or other solid surface material specified or selected.
1. Comply with N.S.F. Standard No. 51.
 2. Acrylic adhesive is to be used for all joints.
 3. Install directly over ¾" thick (minimum) substrate of close grained plywood, such as solid Mahogany or solid Birch, of selected, smooth, sanded stock to ensure a smooth ripple-free surface; or commercial grade furniture particle board, Cortron or equal. Additional bracing and support to be provided as required by the SSM manufacturer.
 4. Fabricator to be trained by DuPont factory authorized training personnel and certified as a Commercial Corian/Zodiaq Fabricator; or equivalent by other SSM manufacturers. If no commercial certification program is available from other manufacturer specified or selected, then fabricator is to be certified as Commercial Corian/Zodiaq Fabricator.
 5. Installer to be trained by DuPont factory authorized training personnel and certified as a Commercial Corian/Zodiaq Installer; or equivalent by other SSM manufacturers. If no commercial certification program is available from other manufacturer specified or selected, then installer is to be certified as Commercial Corian/Zodiaq Installer.

6. All fabrication and installation of Corian/Zodiaq, and all components attached to or installed in or through Corian/Zodiaq are to be in compliance with manufacturer's instructions and the DuPont Corian/Zodiaq Commercial Food Service Installation bulletins. Of particular concern are the sections, details, and instructions on the installation of drop-in or built-in hot or cold components. The DuPont Corian/Zodiaq Food Service Installation bulletins requirements are to also apply to any other SSM, in addition to that manufacturer's instructions.
7. KEC to verify and coordinate overhead heat lamps and/or food warmers to be installed in accordance with manufacturer's recommendations over solid surface materials and solid surface materials manufacturer's recommendations.
8. All surfaces are to be non-porous or cleaned and sealed, in compliance with local health codes; such as with 511 Impregnator by Miracle Sealants for granite.

2.02 QUALITY ASSURANCE

- A. It is required that all fabricated equipment described in specifications and designated on drawings shall be manufactured by one equipment manufacturer which has engineering personnel and plant facilities to design, detail and fabricate the highest quality equipment in strict compliance with appropriate standards of National Sanitation Foundation.
- B. All exposed surfaces shall be free from bolt, screw and rivet heads. When bolts are required they shall be of concealed type and be of similar composition as the metal to which they are applied. Where bolt or screw threads on the interior of fixtures are visible or may come in contact with heads or wiping cloth they must be capped with a stainless steel acorn nut with a stainless steel lock washer.
- C. Where screw threads are not visible or readily accessible, they may be capped with a standard lock washer and steel nut treated to prevent rusting or corroding. Where bolts or screws are welded to the underside of trim or tops, the reverse side of the weld shall be neatly finished uniform with the adjoining surface of the trim or the top. Depressions at these points will not be acceptable. Rivets shall not be used as a method of fastening in any location.
- D. All welds, bolts, screws, nuts, washers, and rivets shall be steel except where brass or stainless steel is fastened, in which case they shall be brass or stainless steel respectively. Where dissimilar metals are fastened, the fastenings shall be of higher grade metal. Spacing and extend of welds, bolts, screws and rivets shall insure suitable fastenings and prevent bulging of metals fastened.
- E. All exposed, welded joints shall be suitably ground flush with adjoining material and neatly finished to harmonize therewith. Wherever material has been sunken or depressed by welding operation, such depressions shall be suitable hammered and peened flush with the adjoining surface and, if necessary, again ground to eliminate low spots. In all cases the grain of rough grinding shall be removed by successive fine polishing operations. All stainless steel shall have a No. 4 finish on all exposed surfaces and a No. 2 finish on all concealed surfaces.
- F. All unexposed welded joints on undershelves of tables or counters in stainless steel construction shall be suitable coated at the factory by means of metallic base point to prevent possible corrosion at such locations.
- G. After galvanized iron members have been welded, all welds and areas where galvanizing has been damaged shall be re-coated to prevent oxidation. Submit a sample of re-coated area complete with a detailed explanation of the method to be used for approval before proceeding.

- H. Butt joints and contract joints, wherever they occur, shall be close fitting and shall not require solder as filler. Wherever break bends occur they shall be free of undue exudence and shall not be flaky, scaly or cracked in appearance of the material all such marks shall be removed by suitable grinding, polishing and finishing. Wherever sheared edges occur they shall be free of burrs, fins or irregular projections and shall be finished to obviate all danger of cutting or laceration when the hand is drawn over such sheared edges. In no case are overlapping materials to be acceptable where miters of bull-nosed corners occur.
- I. The grain of polishing shall run in the same direction on all horizontal and on all vertical surfaces of each individual item of fabricated equipment, except in the case where table or sink tops join at right angles, where the finish of the horizontal sections of each terminating in a mitered edge shall be acceptable. Where sinks and adjacent drain boards are equipped with splash back, the grain of polishing shall be consistent in direction throughout the length of the splash back and sink compartment.
- J. Where stainless steel surfaces are distributed by the fabricating process, such surfaces shall be finished to match the adjoining surfaces.
- K. Final Polishing: At the completion of the installation work, all stainless steel shall be gone over with a portable polishing machine and buffed to perfect surfaces. All painted surface shall be carefully gone over and retouched as required.

2.03 FABRICATION COMPONENTS

A. Hardware :

1. General: Manufacturer's standard, but not less than ANSI 156.9 Type 2 (institutional), satin finish stainless steel or dull chrome finish on brass, bronze, or steel.
2. Metal Hinged Door Hardware: Doors to be mounted on Component Hardware Group model M75-5003, or equal, stainless steel, heavy duty, lift-off flag hinge that is 3" long and NSF approved with a swedged knuckle design. Door to be fitted with Component Hardware Group model P63-1012, or equal, stainless steel full grip type with frame beveled edge pull. Catches to be heavy-duty magnetic type, except as otherwise indicated.
3. Sliding Door Hardware: Doors to be mounted on large, quiet ball bearing rollers in 14 gauge stainless steel overhead tracks, and be removable without the use of tools. Bottom of cabinet to have stainless steel guide-pins and not channel tracks for doors.
4. Millwork Hinged Door Hardware: Doors to be mounted with Blum 95 degree CLIP top thick door all metal hinges, nickel plated, with 3 dimensional adjustment, or equal; or as per individual itemized specifications.
5. Drawer Hardware: Slides to be Component Hardware Group series S52, or equal, with 200 pounds minimum capacity per pair, 201 or 300 series stainless steel, full extension, side-mounting, self-closing type, with stainless steel ball-bearings, and positive stops. Drawer front to be fitted with Component Hardware Group model P63-1012, or equal, stainless steel full grip type with frame beveled edge pull.
6. All hardware to be identified with manufacturer's name and number, so that broken or worn parts may be replaced.

B. Casters:

1. Type and size as recommended by caster manufacturer, N.S.F. approved for the type and weight of equipment supported; normally 5" diameter heavy-duty, ball-bearing, solid or disc wheel with non-marking grease proof rubber, neoprene or

- polyurethane tire; unless otherwise specified. Minimum width of tread to be 1-3/16". Minimum capacity per caster to be 250 pound, unless otherwise noted in itemized specifications.
2. Solid material wheels to be provided with stainless steel rotating wheel guard.
 3. To be sanitary, have sealed wheel and swivel bearings and polished plate finish per N.S.F.
 4. Unless otherwise indicated, equip each item with two (2) swivel-type casters and two (2) fixed casters, with foot brakes on two (2) casters.
 5. Unless item is equipped with another form of all-around protective bumper, provide circular rotating bumper above each caster, 5" diameter tire of light grey synthetic rubber (hollow or closed-cell) on cadmium-plated disc.
- C. Plumbing Fittings, Trim & Accessories:
1. General: Where exposed or semi-exposed, provide bright chrome plated brass or polished stainless steel units. Provide copper or brass where not exposed.
 2. Vacuum Breakers: Provide with foodservice equipment as listed in the itemized specifications.
 3. Water Outlets: At sinks and at other locations where water is supplied (by manual, automatic or remote control), furnish commercial quality faucets, valves, dispensers or fill devices, of the type and size indicated, and as required to operate as indicated.
 4. Waste Fittings: Except as otherwise indicated, furnish 2" NPS twist handle drain with overflow assembly and crumb cup strainer, similar to Component Hardware Group #D53-7215.
 5. Also refer to article 2.04 for additional information.
- D. Electrical Materials:
1. General: Provide standard materials, devices and components as recommended by the manufacturer or fabricator, selected and installed in accordance with N.E.M.A. standards and recommendations; and as required for safe and efficient use and operation of the foodservice equipment, without sanitation problems.
 2. Components to bear the U.L. label or be approved by the prevailing authority.
 3. Where light fixtures are specified or detailed as part of counters, cases or fixtures; light fixtures with lamps to be furnished and installed. Warm white lamps to be provided, unless otherwise specified. If fluorescent light fixtures are specified, ballasts and tubes to be provided. Shields to be provided for all light fixtures.
 4. Convenience and Power Outlets: Make cutouts and install appropriate boxes or outlets in fabricated fixtures, complete with wiring, conduit, outlet and stainless steel cover plate. Outlets and plugs to conform to N.E.M.A. standards. Electrical outlets and devices to be first quality "Specification Grade". GFCI outlets to be furnished where adjacent to sink compartments, as per the National Electrical Code.
 5. Plugs & Cords: Where cords and plugs are provided, they are to comply with N.E.M.A. requirements. Indicate N.E.M.A. configuration for each applicable item.
 6. Power Characteristics: Refer to Electrical Divisions specifications for project power characteristics. Also, refer to individual equipment requirements for loads and ratings.
 7. All electrical components (J-boxes, conduit, outlets, switches, cover plates, light fixtures, panels, etc.) built into or on any equipment provided by the KEC, other than standard buy-out factory manufactured equipment, are to be vapor or water tight type. Provide buy-out equipment with vapor or water tight electrical components wherever available.

2.04 FABRICATED PRODUCTS

A. General Fabrication Requirements:

1. Except as otherwise indicated, provide framing of minimum 1" pipe-size round pipe or tube members, with mitered and welded joints and gusset plates, ground smooth. Provide 14 gauge stainless steel tube for exposed framing, and galvanized steel pipe for concealed framing.
2. Reinforce metal at locations of hardware, anchorages and accessory attachments wherever metal is less than 14 gauge, or requires mortised application. Conceal reinforcements to the greatest extent possible. Weld in place, on concealed faces.
3. Provide removable panels for access to mechanical and electrical service connections, which are concealed behind or within foodservice equipment, buy only where access is not possible and not indicated through other work.
4. Where ends of fixtures, splash backs, shelves, etc., are open, fill by forming the metal or welding sections, if necessary, to close entire opening flush to walls or adjoining fixtures.
5. Rolled edges are to be as detailed, with corners bull nosed, ground and polished.
6. Equipment to have $\frac{3}{4}$ " or larger radius coves in horizontal and vertical corners, and intersections, per N.S.F. standards.

B. Metal & Gauges:

1. Except as otherwise indicated, fabricate exposed metalwork of stainless steel; and fabricate the following components from the gauge of metal indicated, and other components from not less than 20 gauge metal:
 - a. Table & counter tops: 14 gauge
 - b. Sinks & drain boards: 14 gauge
 - c. Shelves: 16 gauge
 - d. Front drawer & door panels: 18 gauge (double-pan type)
 - e. Single pan doors and drawer fronts: 16 gauge
 - f. Enclosed base cabinets: 16 gauge
 - g. Enclosed wall cabinets: 16 gauge
 - h. Exhaust hoods & ventilators: 18 gauge
 - i. Pan-type insets & trays: 16 gauge
 - j. Removable covers & panels: 18 gauge
 - k. Skirts and enclosure panels: 18 gauge
 - l. Closure & trim strips over 4" wide: 18 gauge
 - m. Hardware reinforcement: 12 gauge
 - n. Gusset plates: 10 gauge

C. Worktable Tops:

1. Construct worktable of 14 gauge stainless steel, one-piece, welded construction, including field joints.
2. Secure to a full perimeter, 4"x1"x 12 gauge, galvanized steel channel frame with channel running front to back at each leg. Two (2) channels lengthwise on worktables up to 30" wide and channels spaced no more than 18" on center for over 30" wide. Fasten top with stud bolts and combination of zinc plated locknut with rubber seal.
3. Where worktables abut wall or other equipment, backsplash or side splashes shall be 6" high, with return to wall of 1" and turn down of 1", unless otherwise specified. Secure backsplash to wall with "Z" clips and enclosed all exposed ends.

- D. Dishtable Tops:
1. Construct dishtables of 14 gauge stainless steel with all intersections meeting in a spherical section.
 2. Secure to a full perimeter, 4"x1"x 12 gauge, galvanized steel channel frame with channel running front to back at each leg. Two (2) channels lengthwise on dishtables up to 30" wide and channels spaced no more than 18" on center for over 30" wide. Fasten top with stud bolts and combination of zinc plated locknut with rubber seal.
 3. Where dishtables abut wall or other equipment, backsplash or side splashes shall be 10" high with 45 degree return to wall of 2" and turn down of 1", unless otherwise specified. Secure backsplash to wall with "Z" clips and enclose all exposed ends.
 4. Slope dishtables to dishmachine, sinks, troughs, cones or drainers at a minimum of 1/8" per foot. Where dishtables lip into dishmachine fasten securely with stainless steel fasteners and seal to insure no water leakage.
 5. Where applicable to project, pass thru shelves, sills or other configurations are to be welded and constructed integral to dishtable.
- E. Edges & Corners: (See detail on first page of elevations)
1. Edges to be die-formed and integral with top.
 2. Where indicated, flange rear and end edges up to form splashes integrally with top, with vertical and horizontal corners coved of not less than 3/4" radius, die formed. Turn back splashes 1" to wall across top and ends with rounded edge on break, unless otherwise specified.
 3. For standard flat edge, turn down 1-1/2" on outside and back at 45 degree angle another 1/2" along return.
 4. For marine splash edge, turn up 1/2" at a 45 degree angle, out 1", turn down 2" and back at a 45 degree angle another 1/2" along return.
 5. For rolled rim edge, turn up 3" with 3/4" coved radius and roll out semi-circle to 3/4" radius.
 6. For rolled edge, roll down semi-circle to 3/4" radius.
 7. For rounded corners, form to 1" radius, weld, and polish to original finish.
- F. Field Joints: For any field joint required because of size of fixture; butt-joint, reinforce on underside with angles of same material, bolt together with non-corrosive bolts and nuts, field weld, grind and polish.
- G. Pipe Bases: Construct pipe bases of 1-5/8" diameter 18 gauge stainless steel tubing. Fit legs with polished stainless steel sanitary adjustable bullet feet to provide for adjustment of approximately 1-1/2", without exposing threads. Space legs to provide ample support for tops; precluding any possibility of buckling or sagging, and in no case more than 6'-0" centers.
- H. Legs & Crossrails:
1. Equipment legs and crossrails to be 1-5/8", 16 gauge stainless steel tubing.
 2. Welds at crossrails to be continuous and ground smooth. Tack welds will not be acceptable. Top of crossrail to be 10" above finished floor.
 3. Bottom of legs to be swedged inward and fitted with a stainless steel bullet-type foot with not less than 2" adjustment.
 4. Free standing legs to be pegged to floor with 1/4" stainless steel rod, or provided with bolt down type flanged feet anchored to the floor; depending on expected severity of use and/or abuse
 5. Components:
 - a. Stainless Steel Gusset: Stainless steel exterior to fit 1-5/8" tubing, with Allen screw for fastening and adjustment. Not less than 3" diameter at top and 3-

- 3/4" long. Outer shell 16 gauge stainless steel, reinforced with 12 gauge mild steel insert welded interior shell, or approved equal.
- b. Stainless Steel Low Counter Legs: Stainless steel exterior 5-3/4" minimum, 7" maximum length with stainless steel 3-1/2" square plate with four counter-sunk holes, welded to top for fastening.
 - c. Stainless Steel Adjustable Foot: Stainless steel 1-1/2" diameter tapered at bottom to 1" diameter, fitted with threaded cold rolled rod for minimum 1-1/2" diameter x 3/4" threaded bushing plug welded to legs, or approved equal. Push-in foot not acceptable.
6. Legs to be fastened to equipment with gussets as follows:
- a. Sinks: Reinforced with bushings and set screw.
 - b. Metal Top Tables & Dish Tables: Welded to galvanized steel channels, 14 gauge or heavier, anchored to top with screws through slotted holes.
 - c. Wood Top Tables: Welded to stainless steel channels, 14 gauge or heavier, anchored to top with screws through slotted holes.
- I. Shelves:
1. Construct solid shelves under pipe base tables of 16 gauge stainless steel, with 1-1/2" turned down and back 1/2" at 45 degree angle on exposed sides, and 2" turn up against walls or equipment. Fully weld to pipe legs at 10" above finished floor.
 2. In fixtures with enclosed bases, turn up shelves on back and sides with 1/4" (minimum) radius and feather slightly to ensure a tight fit to enclosure panels.
 3. Construct wall shelves of 14 gauge stainless steel, with 1-1/2" turned down and back at 45 degree angle on exposed sides, and 1-1/2" turn up against walls or equipment. Support wall shelves with 14 gauge stainless steel triangle brackets secured to wall with stainless steel fasteners.
- J. Sinks:
1. Construct sinks of 14 gauge stainless steel with No. 4 finish inside and outside.
 2. Form back, bottom and front of one piece, with ends and partitions welded into place. Partitions: double thickness, 1" minimum space between walls. Multiple compartments to be continuous on the exterior, without applied facing strips or panels.
 3. Cove interior vertical and horizontal corners of each tub not less than 3/4" radius, die formed. Outer ends of drain boards to have roll rim risers not less than 3" high.
 4. Drill faucet holes in splashes 2-1/2" below top edge. Verify center spacing with faucet specified.
 5. Sink inserts to be drawn of 14 gauge, or heavier, polished stainless steel. Weld into sink drain boards with 1-1/2" x 1-1/2" x 14 gauge stainless steel angle brackets; securely welded to sinks and galvanized cross angles spot welded to underside of drain boards to form an integral part of the installation.
 6. The bottom of each compartment is to be creased such as to ensure complete drainage to waste opening. Slope bottom of sink bowls toward outlet.
- K. Drains, Wastes & Faucets:
1. Furnish and install Component Hardware Group#D63-4590, or equal, twist handle box pattern drain with overflow assembly, with chrome finish, in die-drawn inset type sinks and bain marie sinks.
 2. Other custom fabricated sinks to be furnished with Component Hardware Group #D53-7215, or equal, twist lever handle waste outlet with overflow assembly and crumb cup strainer. Waste connection to have 2" external thread size, with 1-1/2" internal thread size.

3. Twist Lever Handle: Of sufficient length to extend to front edge of sink. No riveting, screws or soldering permitted to fit drains to sinks, with all parts of drains easily removable for servicing and replacement. Furnish stainless steel twist lever handle support for each drain.
 4. All faucets furnished with equipment included in this Section to be lead free and comply with N.S.F. Standard #61, Section #9; such as manufacturer by Fisher, Chicago or T&S Brass.
 5. Faucets and pre-rinse spray assemblies furnished with equipment included in this Section, are to have a maximum GPM flow rate in compliance with the Energy Policy Act of 2005 (EPAAct) and later updates; or local requirements, whichever is lower. EPAAct / local requirements are to be applicable to all faucets and pre-rinses, except for pre-rinse type assemblies used at glass icing/fill stations, fill hose/faucet assemblies at high water usage cooking equipment such as kettles, tilt fry pans, etc., and fill faucets at high volume/usage sinks such as pot and prep sinks, etc. are to have flow rates of approximately 5 gpm flow minimum.
 6. All flex hose type faucet assemblies, such as pre-rinses, kettle fill hoses, etc. to have an inline pressure type back flow preventer in the hose assembly, as required by local codes.
 7. All equipment provided by the KEC, which discharges liquid waste exceeding 140 degrees F, is to be provided with a cold water drain tempering assembly per local codes.
- L. Workmanship:
1. Best quality in the trade. Field verify dimensions before fabricating; conform all items to dimensions of building; neatly fit around pipes, offsets and other obstructions.
 2. Fabricate only in accordance with approved shop drawings, showing pipes, obstructions to be built around, and location of utilities and services.
- M. Casework:
1. Enclosure: except as otherwise indicated, provide each unit of casework (base, wall, overhead and free-standing) with a complete-enclosure metal cabinet, including fronts, backs, tops, bottoms, and sides.
 2. Bases to be made of 16 gauge stainless steel sheets reinforced by forming the metal.
 3. Unexposed backs and structural members may be galvanized, unless otherwise noted.
 4. Vertical ends and partitions to be stainless steel fully enclosed and completely vermin proof with a 2" face and 3/4" return.
 5. Sides and through partitions are flush with bottom rail, welded at intersections.
 6. Shelves: Provide adjustable standards for positioning and support of shelves in casework; except bottom shelf of cabinet mounted on legs or as specified. Turn back of shelf units up 2" and hem. Turn other edges down to form open channel. Reinforce shelf units to support 40 pounds per square foot loading, plus 100 percent impact loading.
 7. Bottom front rail of bases set on masonry platform to be continuously closed and sealed to platform.
- N. Doors:
1. Metal doors to be double-cased stainless steel. Outer pans to be 18 gauge stainless steel and inner pans to be 20 gauge stainless steel fitted tightly into outer pan with a sound deadening, moisture proof, fire proof, and vermin proof material used as a core. The two pans to be tack welded together and joints solder fitted. All corners to be welded, ground smooth and polished.

2. Metal doors to finish approximately $\frac{3}{4}$ " thick and be fitted with Component Hardware Group #P63-1012, or equal, stainless steel full grip type with frame beveled edge door pull.
 3. Hinged doors to be mounted on Component Hardware Group #M75-5003, or equal, stainless steel heavy duty lift-off flag hinge. Hinge to be 3" long, NSF approved with swedged knuckle design.
 4. All doors to be furnished with stainless steel faced, disc tumbler, utility lock. All locks to be keyed alike.
 5. All doors to be easily removable without the use of tools.
- O. Drawer Assemblies:
1. Assemblies to consist of removable drawer body mounted in a ball bearing slide assembly with fully enclosed housing. Assembly to have unibody fully welded construction throughout.
 2. Slide assembly consists of one pair of 200 pound capacity stainless steel roller bearing full extension slides, with side and back enclosure panels, front spacer angle, two drawer carrier angles, secured to slides and stainless steel front.
 3. Drawers intended for tools and general non-food products storage are to have 20" x 20" x 5" deep, 18 gauge minimum stainless steel drawer pans.
 4. Drawers intended to hold food products are to have 12" x 20" x 5" deep, 18 gauge stainless steel food pans.
 5. All drawer pans to be easily removable without tools or disassembly of any drawer assembly components.
 6. Drawer fronts are double cased, $\frac{3}{4}$ " thick, with 16 gauge stainless steel welded and polished front pan. Steel back pan is tightly fitted and tack welded. Sound deaden with rigid insulation material.
 7. Provide drawers with replaceable soft neoprene bumpers or for refrigerated drawers, a full perimeter replaceable refrigerator gasket.
 8. All drawers to be finished with stainless steel faced, disc tumbler, utility lock. All locks to be keyed alike.
- P. Closed Base: Where casework is indicated to be located on a raised-floor base, prepare casework for support without legs, and for anchorage and sealant application, as required for a completely enclosed and concealed base.
- Q. Support from Floor: Equip floor supported mobile units with casters, and equip items indicated as roll-out units, with manufacturer's standard one-directional rollers. Otherwise, and except for closed-base units, provide pipe or tube legs, with adjustable bullet-design feet for floor supported items of fabricated metalwork. Provide 1-1/2" adjustment of feet (concealed threading).
- R. Shop Painting:
1. Clean and prepare metal surfaces to be painted; remove rust and dirt. Apply treatment to zinc coated surfaces, which have not been mill phosphatized. Coat welded and abraded areas of zinc coated surfaces, with galvanize repair paint.
 2. Apply 1.5 mil (dry film thickness) metal primer coating, followed by 2, 1.0 mil (dry film thickness) metal enamel finish coatings.
 3. Bake primer and finish coatings in accordance with paint manufacturer's instructions for a baked enamel finish.
- S. Sound Deadening:
1. Sound deaden underside of metal tops, drain boards, undershelves, cabinet interior shelves, etc., above the underbracing/reinforcing/framing only.

2.05 MILLWORK

- A. All products shall be of first or best quality and conform to “custom grade” as specified by The Architectural Woodwork Institute.
- B. Flame spread rating of Class II per the ASTM e-84 where specified.
- C. Plastic laminate cabinets to conform to Custom Grade per Section 400b AWI unless otherwise specified.
 - 1. Cabinet body to be $\frac{3}{4}$ ” thick plywood with plastic laminate on all exposed interior and exterior surfaces.
 - 2. Doors and drawer fronts to be $\frac{3}{4}$ ” plywood with plastic laminate on all exposed interior and exterior surfaces. Drawer box to have $\frac{1}{2}$ ” hardwood sides. Drawer bottom to be $\frac{1}{4}$ ” plywood with plastic laminate where exposed. Drawer corners to be lock shoulder joined, glued and screwed. Drawer bottom set in groove cut into all side pieces and glued. Attach drawer box to front with screws from box side, independent of drawer pulls.
 - 3. Shelves to be adjustable on Knappe and Vogt KV255AL/KV256AL standards and supports and constructed of $\frac{3}{4}$ ” plywood with plastic laminate on all surfaces.
 - 4. Hinges to be Grass System #1200 or equal. Pulls to be polished chrome wire. Drawer slides to be full extension, ball bearing 75#/pair capacity Knappe and Vogt #1300 or equal.
 - 5. Counter tops shall be fabricated of $\frac{3}{4}$ ” plywood with plastic laminate or solid polymer surface as specified. Edges shall be 1-1/2” high and covered with matching finish surface material as laminate tops. Edges of solid polymer tops shall be chemically attached to top with adhesive as recommended by the manufacturer, sanded smooth for an invisible joint and of the size shown. Backsplash where shown also to be covered with a finish matching top surface material.
 - 6. Counters to be fabricated of one piece unless top is larger than can be cut from a standard sheet of material. Where splines are required, joints shall touch throughout the length and be flush to within tolerance of .005”. Field assemblies with bolt-up type fasteners. Splines shall not be made at cutouts.
 - 7. Provide material samples and/or mock-up as required.
 - 8. General construction to be of AWI grade birch hardwood framing and $\frac{3}{4}$ ” APA A-B hardwood or marine grade plywood. Fiberboard, pressboard or equal will not be acceptable.
 - 9. Plastic laminate to be suede or matte finish high wear .050 general purposes as manufactured by Formica, Wilson-Art, and Nevamar or as specified.
- D. Adhesive as recommended by manufacturer. Solid polymer to be cast, filled acrylic (not coated, laminated or of composite construction) meeting ANSI Z-124-1980 Type 6, of thickness as specified and manufactured by E.I. Dupont de Nemours and Company/Corian, Wilson Art International/Gibraltar or Formica/Surrell. Fabricator certified in writing by the solid polymer material manufacturer shall do fabrication and installation. Work to be done in such a manner as to ensure compliance with the manufacturer’s warranty and assure a quality installation. Utilize manufacturer’s two part joint adhesive kit to create inconspicuous, non-porous joints.

2.06 MISCELLANEOUS MATERIALS & FABRICATION

- A. Nameplates: Whenever possible, locate nameplates and labels on manufactured items, in accessible position, but not within customer’s normal view. Do not apply name plates or labels on custom fabricated work, except as required for compliance with governing regulations, insurance requirements, or operator performance.

- B. **Manufactured Equipment Items:** Furnish items as scheduled or herein specified. Verify dimensions, spaces, rough-in and service requirements, and electrical characteristics, before ordering. Provide trim, accessories and miscellaneous items for complete installation.
- C. **Insert Pans:**
 - 1. **General:** Cut-outs, openings, drawers, or equipment specified or detailed to hold stainless steel insert pans to be provided with a full complement of pans as follows:
 - a. One (1) stainless steel, 20 gauge minimum, solid insert pan for each space, sized per plans, details, or specifications.
 - b. Where pan sizes are not indicated in plans, details, or specifications, provide one full-size pan for each opening.
 - c. Provide maximum depth pan to suit application and space.
 - 2. Provide 18 gauge removable stainless steel adapter bars where applicable.
 - 3. All cut-outs and openings, or equipment specified or detailed to hold stainless steel insert pans, shall be provided with a hinged stainless steel removable night cover.
- D. **Tray Slides:** Before fabrication of counters with tray slides, verify:
 - 1. Size and shape of tray with Owner/Operator. Edge of tray should not overhang outer support/slider by more than 2". If edge of tray exceeds this dimension, notify Architect, in writing, for evaluation and adjustment, if necessary.
 - 2. Configuration of corners, turns, and shape of tray slides for proper support and safe guidance of trays.
 - 3. Tray slide to be capable of supporting 200 pounds per linear foot, live load.
- E. **Self-leveling Dispensers:** Verify type, make dimensions and weight of ware with Owner/Operator; and submit to the dispenser manufacturer, for proper sizing and calibration of dispensers.
- F. **Carbon Dioxide (CO2) Equipment:** Where equipment requires connection with compressed CO2 cylinder for operation, provide 2-cylinder manifold and control system (integral with equipment) with proper connectors for Department of Transportation (DOT) approved type cylinders, complete with cylinder safety devices and supports. Applicable to projects with CO2 equipment included in Contractor's specified equipment.
- G. Reasonable quietness of operation of equipment is a requirement, and Contractor will be required to replace or repair any equipment producing out of the ordinary intolerable noise. This also includes providing and installing bumpers and gaskets for doors and drawers on fabricated and standard manufactured items and sound insulation where feasible.
- H. **Gas Pressure Regulator:** All gas fired equipment included with this Section is to be provided with a gas pressure regulating valve with a built-in vent limiting device. Contractor is responsible for coordinating this requirement with their manufacturers and suppliers.

PART 3 - EXECUTION

3.01 SUPERVISION

- A. A competent supervisor, representing the KEC, is to be present at all times during progress of the KEC's work.

- B. The KEC is responsible for coordinating all general and specific requirements included in Parts 1, 2, and 3 of this Section 114000 general condition, with their manufacturers, fabricators, and suppliers.

3.02 SITE EXAMINATION

- A. Verify site conditions under the provisions of the General Conditions, Supplementary Conditions and applicable provisions of Division 1 Sections. Notify the Architect, in writing, of unsatisfactory conditions for proper installation of foodservice equipment.
- B. Verify wall, column, door, window, and ceiling locations and dimensions. Fabrication and installation should not proceed until dimensions and conditions have been verified and coordinated with fabrication details.
- C. Verify that wall reinforcement or backing has been provided, and is correct for wall supported equipment. Coordinate placement dimensions with wall construction section.
- D. Verify that ventilation ducts are of the correct characteristics, and in the required locations.
- E. Verify that utilities are available, of the correct characteristics, and in the required locations.

3.03 INSTALLATION

- A. Sequence installation and erection to ensure correct mechanical and electrical utility connections are achieved.
- B. Install items in accordance with manufacturer's instructions.
- C. Set each item of non-mobile and non-portable equipment securely in place, leveled and adjusted to correct height. Anchor to supporting substrate where indicated, and where required for sustained operation and use without shifting or dislocation. Conceal anchorages wherever possible. Adjust counter tops and other work surfaces to a level tolerance of 1/16" (maximum offset, and plus or minus on dimension, and maximum variation in 24" run from level or indicated slope). Provide anchors, supports, bracing, clips, attachments, etc., as required to comply with the local seismic restraint requirements. The Guidelines For Seismic Restraint Of Kitchen Equipment, as prepared for the Sheet Metal Industry Fund of Los Angeles and endorsed by S.M.A.C.N.A., is to be followed.
- D. Complete field assembly joints in the work (joints which cannot be completed in the shop) by welding, bolting-and-gasketing, or similar methods as indicated and specified. Grind welds smooth and restore finish. Set or trim flush, except for "T" gaskets as indicated.
- E. Provide closure plates and strips where required, with joints coordinated with units of equipment.
- F. Provide sealants and gaskets all around each unit to make joints airtight, waterproof, vermin-proof, and sanitary for cleaning purposes.
- G. Joints up to 3/8" wide, to be stuffed with backer rod, to shape sealant bead properly, at 1/4" depth.
- H. At internal corner joints, apply sealant or gaskets to form a sanitary cover, of not less than 3/8" radius.
- I. Shape exposed surfaces of sealant slightly concave, with edges flush with faces of materials at joint.

- J. Provide sealant filled or gasketed joints up to 3/8" joint width. Wider than 3/8", provide matching metal closure strips, with sealant application each side of strips. Anchor gaskets mechanically, or with adhesives to prevent displacement.
- K. Treat enclosed spaces, inaccessible after equipment installation, by covering horizontal surfaces with powdered borax at a rate of 4 ounces per square foot.
- L. Insulate to prevent electrolysis between dissimilar metals.
- M. Cut and drill components for service outlets, fixtures, piping, conduit, and fittings.
- N. Verify and coordinate the mounting heights of all wall shelves and equipment, with equipment located below them, for proper clearances.
- O. Coordinate with Plumbing and Electrical Divisions, and provide holes in food service equipment for plumbing and electrical service to and through the fixtures, as required. This includes welded sleeves, collars, ferrules, or escutcheons. These services are to be located so that they do not interfere with intended use and/or servicing of the fixture.
- P. All equipment provided by this Section, which requires light bulb(s), are to be provided with heavy-duty, energy efficient, extra-long life bulbs with a minimum life expectancy of 5000 hours, and as required by the local Jurisdictions. All light bulbs in and/or above foodservice equipment and/or areas are to be coated or provided with shields in compliance with local health codes.
- Q. All equipment provided by this Section, shall include any and all parts, components, options, accessories, etc. necessary to provide a completely functional item for its intended use under normal conditions; and if appropriate, after the final utility connections are completed by other Divisions. This shall generally apply to equipment such as soda systems, beer systems, and remote refrigeration systems, any type remote system or equipment, or ice machines; but shall also apply to any equipment provided by this Section.

3.04 ADJUSTING

- A. Test and adjust equipment, controls and safety devices to ensure proper working order and conditions.
- B. Repair or replace equipment which is found to be defective in its operation, including units which are below capacity or operating with excessive noise or vibration.

3.05 CLEANING AND RESTORING FINISHES

- A. After completion of installation, and completion of other major work in foodservice areas, remove protective coverings and clean foodservice equipment, internally and externally.
- B. Restore exposed and semi-exposed finishes, to remove abrasions and other damages; polish exposed metal surfaces and touch-up painted surfaces. Replace work, which cannot be successfully restored.
- C. Polish glass, plastic, hardware and accessories, fixtures and fittings.
- D. Wash and clean equipment, and leave in a condition ready for the Owner to sanitize and use.

3.06 TESTING, START-UP AND INSTRUCTIONS

- A. Delay the start-up of equipment until service lines have been tested, balanced, and adjusted for pressure, voltage and similar considerations; and until water and steam lines have been cleaned and treated for sanitation.

- B. Prior to demonstration, the KEC shall arrange for every item to be started-up, checked out, properly calibrated and adjusted by an authorized service agency.
- C. Make arrangements for demonstration of foodservice equipment operation and maintenance, in advance with the Owner/Operator. KEC shall notify the FFC and Architects so that they may be present.
- D. Demonstrate foodservice equipment, to familiarize the Owner and the Operator on operation and maintenance procedures, including periodic preventative maintenance measures required. Include an explanation of service requirements and simple on-site service procedures, as well as, information concerning the name address and telephone number of qualified local source of service. The individual(s) performing the demonstration are to be knowledgeable of operating and service aspects of the equipment. KEC to be onsite for all demonstrations.
- E. Provide a written report of the demonstration, to the Owner, outlining the equipment demonstrated and any malfunctions or deficiencies noted. Indicate individuals present at the demonstration. Notify the FFC and Architect in writing that demonstrations/instructions have been completed with statement from Owner and the Operator that proper demonstrational instruction has satisfactorily been completed. Once this has been completed final jobsite inspection will be performed.
- F. Final Cleaning: After testing and start-up, clean the foodservice equipment, and leave in a condition ready for the Owner to sanitize and use.
- G. All keys for all locks provided with equipment provided under this Section, are to be gathered up, individually tagged with the equipment they belong to, put into a single box, and handed over to the Owner's authorized representative. A list of the keys and their associated equipment item numbers is to be provided with the O&M Manuals, along with a copy of the list, signed by the Owner's representative, acknowledging receipt of the keys.

3.07 CLEAR AWAY

- A. Throughout the progress of their work, the KEC is to keep the working area free from debris, and remove rubbish from premises resulting from work being done by them. At the completion of their work, the KEC is to leave the premises in a clean and finished condition.

3.08 EXISTING EQUIPMENT (Applicable to projects with reused existing equipment)

- A. The KEC is responsible for identifying, tagging and/or removing all existing equipment, which will be reused. Verify and coordinate specific equipment with these plans and specifications, and the Owner. This includes items existing, and the associated work necessary, at the time of the signing of the Contract for the foodservice equipment section; and does not include any items added, changed, or damaged (by other than the KEC) after the signing; except to the extent of work which would have been included with the original existing items.
- B. Remove from existing locations, clean and renovate as noted below, store and re-install existing equipment to be reused, in the new locations as shown on plans; ready for utility connections, as appropriate. Existing equipment to be reused, with utility connections, to be removed after disconnection as noted in paragraph J below.
- C. Do work in cooperation with Owner, so that normal functioning of services is minimally interrupted. Coordinate all removal and replacement scheduling with the Construction Scheduling Manager (or similar responsible party), to insure adequate time to complete the necessary work. If adequate time to properly relocate and reset the

- existing items, and complete all cleaning and repair will not be available, due to continuing use of the existing items, or the allotted construction time; contact the Owner and obtain a written agreement as to what work is to be deleted or delayed; such as cleaning, repainting, or repairs.
- D. All surface dirt, grease, oil, food residues, ingredients, extraneous matter and other soiling materials is to be removed in order to obtain minimum acceptable sanitation and food service standards. Thorough final rinsing of all cleaning agents to be at a minimum temperature of 180 degrees Fahrenheit where possible without damage to equipment or controls. Otherwise, use USDA approved cleaning agents and/or cleaning agents, which are acceptable for use with commercial food service equipment. This includes all exterior surfaces of the existing equipment to be reused, and interior work surfaces such as inside oven compartments, fryer vats, warewashers, etc.
 - E. All painted items with major paint blemishes to be sanded, primed, and repainted to match the original color and type paint. Primer and paint to be of a type approved for use with commercial food service equipment. All controls, lights, view windows, non-painted parts, etc. to be protected as recommended by the Manufacturer. Minor paint blemishes can be touched-up in a professional manner. This work is to be included in the bid submittal, as a separate line cost, at the end of the bid submittal.
 - F. Replace and/or repair minor broken parts to produce a cleanable and functional item. Repairs and/or parts are for minor required items such as control knobs, handles, pilot lamps, belts, oil changes, minor adjustments and recalibrations, etc. This does not include addition or replacement of any wearing components such as cutters, blades, etc.; or any accessory components such as mixer beaters, hooks, whips, etc., except for presently existing accessory components which are broken and non-functional, or as noted in the itemized specifications.
 - G. Where required by local code authorities, provide additional parts and/or modifications to comply with code requirements in place at the time of this project.
 - H. Where required, remove reused existing equipment from the premises for repairs, alterations and cleaning.
 - I. Refer to schedule on the foodservice drawings and to the itemized specifications at the end of this section, for reused existing equipment.
 - J. Disconnection of existing equipment to be relocated and/or reused and disconnection and removal/disposal of existing equipment, which will not be reused, is work as designated by the Architect, and not included in this section. (see page 114000-1, 1.02.E)
 - K. Cost estimates for any repairs and/or parts more than the minor items stated above, or repairs requiring significant disassembling of the item, should be submitted to the Owner, for consideration and approval as an addition to the Contract. In general, this would be considered as any repairs and/or parts amounting to an estimate up to 10% of the cost of a comparable new item.
 - L. The Owner has salvage rights to all existing equipment. Existing equipment that is not to be reused, or claimed by the Owner, shall be removed by the contractor and disposed of as directed by the Architect/Owner.

3.09 ITEMIZED SPECIFICATIONS

- A. Refer to the following pages for specific specification information on each item included in this section.

ITEMIZED SPECIFICATIONS

Note: Per 1.07 'A' of this section the basis of design for all drawings, specifications, and detail references is the first manufacturer and model listed. If another listed manufacturer is chosen by the KEC, it is the responsibility of the KEC to provide a model that is equal in production capabilities, capacity, and performance to the first manufacturer and model listed. The KEC is also to verify, coordinate, and allow for proper installation of equipment; taking into account possible revisions for utility connections, loads, and physical sizes. In the event there are any up charges or change orders by other trades as a result of the KEC submitting another listed manufacturer, those charges shall be the sole responsibility of the KEC.

ITEM #1 Single Door Roll-In Refrigerator
MFGR: Traulsen or Approved Equal
MODEL: RRI134LUT-FHS

Provide and set-in place two (2) only Single Door Roll-In Refrigerator per plan. Complete with all standard accessories.

Consisting of:

- a. Digital temperature display.
- b. Full-height solid door.
- c. Door hinged per plan
- d. Cam-lift hinges.

ITEM #2 Spare Number

ITEM #3 Spare Number

ITEM #4 Spare Number

ITEM #5 Spare Number

ITEM #6 Spare Number

ITEM #17 Stainless Steel Wall Panels
MFGR: IEL, Conover Custom Fabrication, LTI or Approved Equal
MODEL: Fabricated

Provide and set-in place one (1) only Stainless Steel Utility Chase per plan. Stainless Steel Utility Chase constructed per Fabrication Section 2.04. Refer to equipment plan, elevations and sections or size and configuration.

Consisting of:

- a. Stainless steel wall panels on LEFT, REAR, and RIGHT side of prep table from floor to underside of stone bar top. To include all joiner strips and end caps for finished installation.

ITEM #8 Hand Sink Faucet
MFGR: T&S Brass or Approved Equal
MODEL: B-1146-04-CR

Provide and set-in place one (1) only Hand Sink Faucets per plan. Complete with all standard accessories.

ITEM #9 Wall-Mounted Hand Sink
MFGR: John Boos or Approved Equal
MODEL: PBHS-W-1410-SSLR

Provide and set-in place one (1) only Wall-Mounted Hand Sinks per plan. Complete with all standard accessories.

ITEM #10 Prep Sink Faucet
MFGR: T&S Brass or Approved Equal
MODEL: B-0226-CC-CR

Provide and set-in place one (1) only Prep Sink Faucets per plan. Complete with all standard accessories.

ITEM #11 Dry Storage Shelving Unit – Provided by Owner / Not in Kitchen Equipment Contract

ITEM #12 Desks & Chairs - Provided By Architect / Not In Kitchen Equipment Contract

ITEM #13 Spare Number

ITEM #14 Exhaust Ventilation System
MFGR: Allied Air or Approved Equal
MODEL: Custom

Furnish exhaust hood(s), exhaust fan(s), supply fan(s), supply air plenum(s), direct-fired gas furnace(s), hood control panel(s) and fire suppression system(s) as specified. System shall meet all requirements as set forth by NFPA 96, UL and NSF.

EXHAUST HOOD: Provide wall mounted style exhaust hood. Hood body to be single wall construction consisting of 18 gauge, type 304 stainless steel polished to a #3 finish on all exposed surfaces. Construction shall be dependent on the structural application to minimize and/or eliminate distortion and other defects. Hoods shall be U.L. Listed construction without exhaust dampers and include concealed grease trough with concealed grease cup. Hood canopies shall be listed to meet NSF and U.L. Listed 710 standards and constructed in accordance with NFPA-96.

BULKHEAD: Coordinate bulkhead requirements with Architect as required; exposed atrium above exhaust duct to second floor ceiling.

EXHAUST HOOD CONTROL PANEL: Provide control panel mounted in fire suppression cabinet at right end of hood. complete with recess mounted fan/light/winter-summer control oil tight switches and solid state Maxitrol dial located on control panel for controlling incoming supply air temperature while obtaining signal from temperature sensor located in the supply air stream. Switches to have function labeling, be internally wired to indicator lights mounted on control panel face and be pre-wired to junction box on top of hood(s). Exhaust switches to be internally wired to hood mounted temperature sensor and an adjustable shut-off delay which is to be factory set for a 15-minute delayed shut-off after cooking equipment cools and the temperature sensors are satisfied. Temperature sensors are to be factory set to 140 degrees Fahrenheit to allow for the exhaust system to activate in the event that the cooking equipment is turned on prior to exhaust system or left on after exhaust system is manually turned off. Additionally, the control panel shall include re-set flame control for indirect gas fired MUA furnace. Coordinate installation of control panel with Utility Distribution System manufacturer.

ELECTRICAL WIRING: Provide single point electrical connection on top of hood for hood lighting power and exhaust and supply fan control. All hood wiring shall be concealed within the hood body. All switches for hood lighting, exhaust/supply fans to be oil tight switches and clearly labeled with etched nameplate indicating switch function.

FILTERS: Provide U.L. classified stainless steel baffle filters. Filter rack mullion to be tack welded to inside end panel. Integral bottom grease filter frame forms a pitched drip guard draining to a stainless steel drip pan. Furnish high efficiency stainless steel filters and stainless steel blank-off panels in size and quantity as required by ventilator. Filters are not to exceed 20" x 20" x 2" in overall size and blank-off panels are not to exceed 6" in width.

LIGHTS: Provide U.L. Listed vapor proof LED light fixtures pre-wired to a common junction box, quantity as needed to reach light intensity dictated by code.

SUPPLY AIR PLENUM: Provide supply air plenum mounted directly in front of the exhaust hoods and at a point below the finished ceiling as dictated by job site conditions. Plenum to be constructed of the same material and finish as hood body with perforated stainless steel panels per drawing.

EXHAUST FAN: Provide one (1) only spun aluminum up-blast type roof mounted exhaust fan. Unit to be belt driven with centrifugal backward inline wheel which is statically and dynamically balanced, UL 762 rated for grease laden air and be complete with externally mounted disconnect switch, curb hinge, and grease collection device. Fan horsepower and performance requirements to be as shown on drawing.

SUPPLY FAN: Provide one (1) only supply fan mounted in outdoor rated cabinet in conjunction with supply furnace. Fan to be size and CFM rated per drawing. Cabinet to be constructed of 18 gauge galvanized steel. Blower inside case to be heavy gauge, rigid steel die stamped housing. Motor to be open drip proof with ball bearings. Motor plate and bearings to be mounted on vibration isolators. Factory wired disconnect switch in unit cabinet to be included. Motor to be furnished with the voltage and phase per drawings. Factory to install motor starters for exhaust and supply fans inside supply fan cabinet. Outside air intake shroud to include four (4) washable aluminum outside air filters. Motorized backdraft damper to be mounted in unit make-up air outlet. Damper to close when unit is turned off to prevent outside air infiltrating into building. Exterior of fan cabinet to be painted.

DIRECT FIRED GAS FURNACE: Provide one (1) only furnace, mounted in outdoor rated cabinet, in conjunction with supply fan. Furnace size, natural gas supply connection and BTU requirement per drawing. Burner box to be all galvanized steel material. Baffle plates to be installed in burner box to provide proper air flow across burner for ordered CFM. Control box to be all galvanized steel material. Cabinet door to be lift-out type for easy access to controls. Burner to have cast iron supports and stainless steel perforated air foils. 30 to 1 turndown ratio for optimum energy efficiency. Spark ignition to be on all control systems. Controls include 50 to 90 degrees operating range. System is ETL Listed per ANSI 283.4-1999 and 283.4a-2001 standards. All components are factory mounted in the furnace. Control voltage to be 115/60/1. Standard manifold to be set for 7" gas pressure. Burner control to be electronic control system. Controls pilot on-off so that standing pilot is not required. Wiring harness is included to provide control voltage from supply fan to furnace.

ROOF CURBS AND EQUIPMENT SUPPORT RAIL: Provide curb style consistent with other curbs furnished for this project. Curb material to be 18 gauge, all welded galvanized construction, height and slope to be determined by job conditions. Curbs to be internally insulated with rigid fiberglass with foil backing. Equipment support rail to be same construction and material as curb with adjustable cap for leveling in the field.

FIRE SUPPRESSION SYSTEM: Provide one (1) only Ansul R-102 fire suppression system. System shall include Ansul test and permit fees. The Ansul system cabinet shall be mounted in a utility cabinet as part of the exhaust hood or on building wall as shown on drawings and dictated by field conditions. Wiring from Ansul tanks located in cabinet to manual pull stations to be done by E.C. in field. Ansul R-102 fire extinguishing system shall protect kitchen hood against grease fires by a completely automatic fire control system of the wet chemical type. Fire detection system shall be capable of detecting fire in the hood, duct, or surface equipment and shall automatically discharge liquid extinguishing agent into the plenum chamber, exhaust duct collar, and cooking appliances areas to ensure against re-ignition or re-flash. System components shall include a spring loaded release mechanism, agent tank brass nozzles with blow off caps and stainless steel (chrome-plated) appliance drops, fusible link detector, wall mounted

emergency pull stations, wall mounted Automan and cabinet, and a mechanical gas valve installed in the gas line serving the cooking equipment (valve provided by fire protections system manufacturer and installed in gas line by plumber.) System installation shall be made by an authorized representative of the system manufacturer and conform to UL 300 requirements and local codes.

EXHAUST SYSTEM WORK BY OTHERS TRADES: Other trades to install the following equipment which will be provided by the KEC: hood(s), exhaust fan(s), supply fan(s), direct fired gas furnace, roof curb(s) as specified.

Other trades to provide and install connecting ductwork (including fire wrap as required) and installation/start-up/air balance/one year service.

ELECTRICAL DIVISION: Provide 120/60/1 20 amp circuit, for hood lights and controls to junction box on top of hood. Provide circuit (for fan motor) to disconnect switch mounted on exterior of exhaust fan cabinet. Extend power wiring from motor starter to connection point on exhaust fan. Provide conduit and four wires from terminal block on exhaust hood to exhaust fan motor starter panel. Provide conduit and three wires from terminal block on hood to micro-switch of fire protection system. Provide and install an octagon box for the fire system pull station, mounting the centerline of the box at 42" above the finished floor. Run ½" conduit from the top of the box to 6" above the ceiling. Pull station to be provided with fire system. Provide and install automatic power shut-off devices (shunt trip breakers or definite purpose contactors) with interlock to fire system micro switch, shutting off all power below the hood (including control voltage) in the event of fire system actuation. This work must be in accordance with N.F.P.A. 17A, IEC, and the I.E.C.

MECHANICAL DIVISION: Provide net room air demand as indicated on the hood system drawings. This air volume is required only when hood system is in operation. Install gas valve (supplied with the fire suppression system) in the main supply line serving the cooking equipment to shut-off gas service to the cooking equipment in the event of fire system actuation.

NOTE: After the KEC and exhaust hood canopy manufacturer has verified all field dimensions, duct collar locations, mounting methods and engineered the canopy with the specified cooking equipment, the KEC is to insert the manufacturer's "as-built" drawings into their mechanical submittals as to verify proper CFM's, static pressures, and overall performance of the system as a whole. The Mechanical Contractor is responsible for a final test and balance of the exhaust hood system.

ITEM #15 Four Burner Range with Oven Base
MFGR: Montague or Approved Equal
MODEL: 124-5

Provide and set-in place one (1) only Four Burner Range with Oven Base per plan. Complete with all standard accessories.

Consisting of:

- a. Provide unit with 1" left rear manifold with pressure regulator.
- b. Cap & stainless steel manifold cover - both left & right.
- c. Provide (4) polyurethane casters (2) locking (2) non locking

ITEM #15.1 Gas Connector Kit
MFGR: T&S Brass or Approved Equal
MODEL: HG-4E-48SK

Provide and set-in place one (1) only Gas Connector Kit per plan. Complete with all standard accessories.

ITEM #16 Countertop Charbroiler
MFGR: Montague or Approved Equal

MODEL: UFLC-18R

Provide and set-in place one (1) only Countertop Charbroiler per plan. Complete with all standard accessories.

Consisting of:

- a. Provide unit with 1" left rear manifold with pressure regulator.
- b. Cap & stainless steel manifold cover - both left & right.

ITEM #16.1 Gas Connector Kit
MFGR: T&S Brass or Approved Equal
MODEL: HG-4E-48SK

Provide and set-in place one (1) only Gas Connector Kit per plan. Complete with all standard accessories.

ITEM #16.2 Countertop Griddle
MFGR: Montague or Approved Equal
MODEL: C18-8T

Provide and set-in place one (1) only Countertop Griddle per plan. Complete with all standard accessories.

Consisting of:

- a. Provide unit with 3/4" left rear manifold with pressure regulator.
- b. Cap & stainless steel manifold cover - both left & right.
- c. Provide 36"W S/S mobile equipment stand with polyurethane casters for griddle and charbroiler

ITEM #16.3 Gas Connector Kit
MFGR: T&S Brass or Approved Equal
MODEL: HG-4D-48SK

Provide and set-in place one (1) only Gas Connector Kit per plan. Complete with all standard accessories.

ITEM #17 Spare Number

ITEM #18 Induction Warmers - Provided By Owner / Not In Kitchen Equipment Contract

ITEM #19 Combi Oven/Steamer
MFGR: Convotherm or Approved Equal
MODEL: 6.10 ET MINI

Provide and set-in place one (1) only Combi Oven/Steamer per plan. Complete with all standard accessories.

Consisting of:

- a. Provide unit with Convotherm Factory Authorized Installation Program.
- b. Provide six (6) total full-size stainless steel wire shelves.
- c. Door hinged: right
- d. Provide unit with CombiClean and Combitherm solutions for one-year of normal use [per manufacturer's recommendation].
- e. Provide Optipure #QT1+CR water filtration system with one (1) additional back up cartridge

ITEM #20 Worktable
MFGR: Advance/Tabco, John Boos, Eagle or Approved Equal

MODEL: AG-3642

Provide and set-in place one (1) only Worktable per plan. Complete with all standard accessories.

Consisting of:

- a. Provide 14 gauge stainless steel one-piece, fully-welded countertop at 36" high with standard flat edge detail on exposed front, sides and rear of countertop.

ITEM #21 Prep Counter w/Sinks
MFGR: Conover Custom Fabrication, LTI or Approved Equal
MODEL: Fabricated

Provide and set-in place one (1) only Prep Counter w/Sinks per plan. Prep Counter w/Sinks constructed per Fabrication Section 2.04. Refer to equipment plan, elevations and sections for size and configuration.

Consisting of:

- a. Provide 14 gauge stainless steel one-piece, fully-welded countertop at 34" high with standard flat edge detail on exposed front, sides and rear of countertop. Where countertop abuts building wall, furnish 2" turn-up back/side and seal thereto.
- b. Three (3) only 12" x 14" x 10" deep fully-welded sinks integral to top with 1" thick wall partition between compartments.
- c. Three (3) only Component Hardware Group #D53-7215 twist lever waste drains.
- d. One (1) only 16" x 20" x 10" deep fully-welded sink integral to top.
- e. Provide splash guard integrally welded to left of sink
- f. Provide space for Undercounter Refrigerator [Item #22] as shown.

ITEM #22 Undercounter Refrigerator
MFGR: True or Approved Equal
MODEL: TUC-60D-2-LP-HC

Provide and set-in place one (1) only Undercounter Refrigerator per plan. Complete with all standard accessories.

Consisting of:

- a. Barrel locks, factory installed.
- b. Exterior digital thermometer, factory installed.
- c. Doors hinged per plan

ITEM #23 Hand Sink Faucet
MFGR: T&S Brass or Approved Equal
MODEL: B-0321-CC-CR

Provide and set-in place one (1) only Prep Sink Faucets per plan. Complete with all standard accessories.

ITEM #24 Walk-In Cooler
MFGR: Nor-Lake or Approved Equal
MODEL: KLB7756-C

Provide and set-in place one (1) only Walk-In Cooler per plan. Complete with all standard accessories.

Consisting of:

- a. ENVIROCONTROL Enviro-Control Electronic Cooler with demand defrost and superheat control
- b. 30"W door hinged RIGHT
- c. #127226 Exterior Kick Plate 30"W x 30"H aluminum diamond tread
- d. #103025 Strip Curtain

ITEM #25 Walk-In Cooler Shelving
MFG: Nor-Lake of Approved Equal
MODEL: SSG56-4

Provide and set-in place (1) only Shelving Kit for 5'x6' walk-in cooler per plan. Complete with all standard accessories.

ITEM #26 Single Door Reach-In Freezer – Provided By Owner / Not In Kitchen Equipment Contract

ITEM #27 Worktable
MFG: Advance/Tabco, John Boos, Eagle or Approved Equal
MODEL: AG-3054

Provide and set-in place one (1) only Worktable per plan. Complete with all standard accessories.

Consisting of:

- a. Provide 14 gauge stainless steel one-piece, fully-welded countertop at 36" high with standard flat edge detail on exposed front, sides and rear of countertop.
- b. One (1) set 5" casters, front locking.

ITEM #28 Heavy-Duty Bun Pan Rack
MFG: Channel Manufacturing or Approved Equal
MODEL: 401A

Provide and set-in place four (4) only Heavy-Duty Bun Pan Racks per plan. Complete with all standard accessories.

(Not shown on drawing)

Consisting of:

- a. Pan stop, aluminum.
- b. Perimeter bumper.
- c. One (1) set 5" x 2" heavy-duty casters with front-locking, heavy-duty caster brakes

ITEM #29 Spare Number

ITEM #30 Mobile Racks - Provided By Owner / Not In Kitchen Equipment Contract

**UNIT PRICE FORM:
 COMMUNIT HIGH SCHOOL DISTRICT 99
 DOWNERS GROVE SOUTH HIGH SCHOOL**

Note: This form, completely filled in, shall be submitted with the bid.

All items in this form shall be filled in and shall be bid as specified. The Bidder is required to list all manufacturers and model numbers of buy-out equipment and the specific fabricator and suppliers of all custom pieces for this project. The successful bidder agrees to supply all items on this bid form as specifically listed. No variations of this form will be accepted without written approval by the Foodservice Consultant.

The amount listed for new items shall include the cost of the item, applicable taxes and installation of that piece of equipment.

ITEM	QTY	DESCRIPTION	MRF./MODEL	UNIT PRICE	TOTAL
1	2	Single Door Roll-In Refrigerator			
2		Spare Number			
3		Spare Number			
4		Spare Number			
5		Spare Number			
6		Spare Number			
7	Lot	S/S Wall Panels			
8	1	Hand Sink Faucet			
9	1	Wall Mounted Hand Sink			
10	1	Deck Mounted Faucet			
11	2	Dry Storage Shelving- Provided By Owner / Not In Kitchen Equipment Contract			
12	3	Desk - Provided By Owner / Not In Kitchen Equipment Contract			
13		Spare Number			
14	1	Kitchen Exhaust System			
15	1	Four Burner Range with Oven			
16	1	Countertop Charbroiler/Grille/Stand			

17	1	Spare Number			
18	2	Induction Warmers - Provided By Owner / Not In Kitchen Equipment Contract			
19	1	Countertop Combi/Steamer			
20	1	Work Table			
21	1	Work Table with Sinks			
22	1	Undercounter Refrigerator			
23	1	Deck Mounted Faucet			
24	1	Walk-In Cooler			
25	1	Cooler Shelving Kit			
26	1	Single Door Reach-In Freezer			
27	1	Mobile Work Table			
28		Spare Number			
29		Spare Number			
30	4	Mobile Racks - Provided By Owner / Not In Kitchen Equipment Contract			
TOTAL BID PRICE:					\$

ACKNOWLEDGEMENT AND ACCEPTANCE:

By signing this document we acknowledge that we have read the complete specification section. Furthermore, we agree to use factory authorized installers and/or supervisors as specifically noted for specialty equipment in this specification section. These systems include, but are not limited to, walk-in cooler/freezers (including refrigeration systems), exhaust systems, and utility distribution systems.

Corporate Name of Bidder: _____

Individual Responsible for this Project: _____

Signature: _____

Date: _____

END OF SECTION 114000

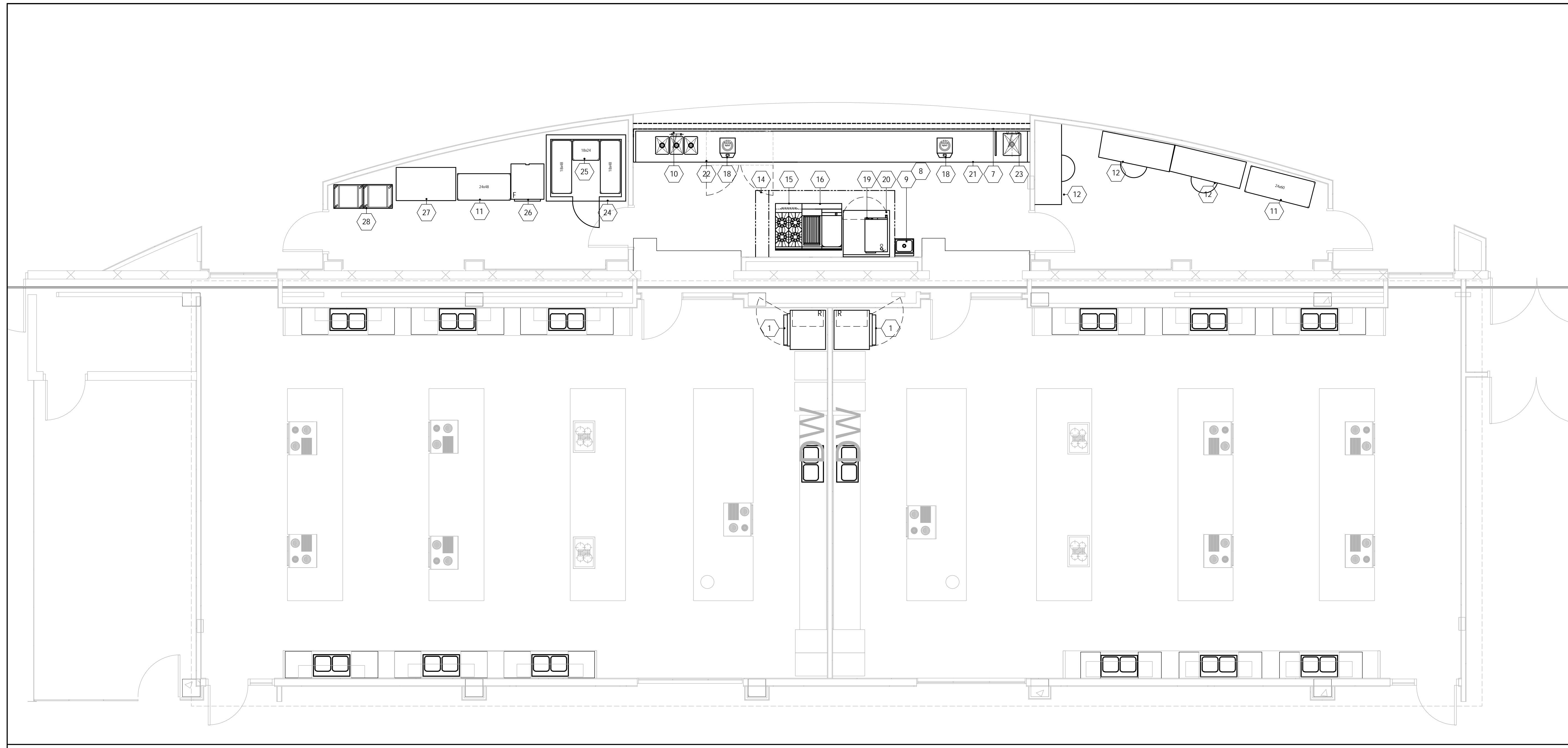

EQUIPMENT SCHEDULE

ITEM	QTY	ITEM DESCRIPTION	MANUFACTURER	MODEL
1	2	SINGLE DOOR ROLL-IN REFRIGERATOR	TRAUlsen	RR134LUT-FHS
2		SPARE NUMBER		
3		SPARE NUMBER		
4		SPARE NUMBER		
5		SPARE NUMBER		
6		SPARE NUMBER		
7	LOT	S/S WALL PANELS	FABRICATED EQUIPMENT	CUSTOM
8	1	HAND SINK FAUCET	T & S BRASS	B-1146-04-CR
9	1	WALL MOUNTED HAND SINK	JOHN BOOS	PBHS-W-1410-SSLR
10	1	DECK MOUNTED FAUCET	T&S BRASS	B-0321-CC-CR
11	LOT	2	PROVIDED BY OWNER	NOT IN KEC CONTRACT
12	3	DESK	PROVIDED BY ARCHITECT	NOT IN KEC CONTRACT
13		SPARE NUMBER		
14	1	KITCHEN EXHAUST SYSTEM	FABRICATED EQUIPMENT	CUSTOM
15	1	FOUR BURNER RANGE WITH OVEN	MONTAGUE	124-5
16	1	COUNTERTOP CHARBROILER/GRIDDLE/STAND	MONTAGUE	UFLC-18R/C18-BT
17		SPARE NUMBER		
18	2	INDUCTION WARMER	PROVIDED BY OWNER	NOT IN KEC CONTRACT
19	1	COUNTERTOP COMBI/STEAMER	CONVO THERM	6-10 ET MINI
20	1	WORK TABLE	ADVANCE TABCO	AG-3642
21	1	WORK TABLE W/SINKS	FABRICATED EQUIPMENT	CUSTOM
22	1	UNDERCOUNTER REFRIGERATOR	TRUE	TUC-60D-2-LP-HC
23	1	DECK MOUNTED FAUCET	T&S BRASS	B-0226-CC-CR
24	1	WALK-IN COOLER	NOR-LAKE	KLB7756-C
25	1	COOLER SHELVING KIT	NOR-LAKE	SSG56-4
26	1	SINGLE DOOR REACH-IN FREEZER	PROVIDED BY OWNER	NOT IN KEC CONTRACT
27	1	MOBILE WORK TABLE	ADVANCE TABCO	AG-3054
28		SPARE NUMBER		
29		SPARE NUMBER		
30	4	MOBILE RACKS	PROVIDED BY OWNER	NOT IN KEC CONTRACT



Kitchen & Servery Renovation Drawings For:
Downers Grove South
 1436 Norfolk St., Downers Grove, Illinois 60516

ISSUED FOR DESIGN DEVELOPMENT - PHASE B
 Foodservice Consultant:
 Reitano Design Group
 302 N. East Street - Studio One
 Indianapolis, Indiana 46202
 T - (317) 637-3204

FOODSERVICE
 EQUIPMENT
 LAYOUT & SCHEDULE

Project Number 2018-025
 Date June 7, 2019
 Drawn By CW
 Checked By RDG

K101
 Scale 1/4" = 1'-0"

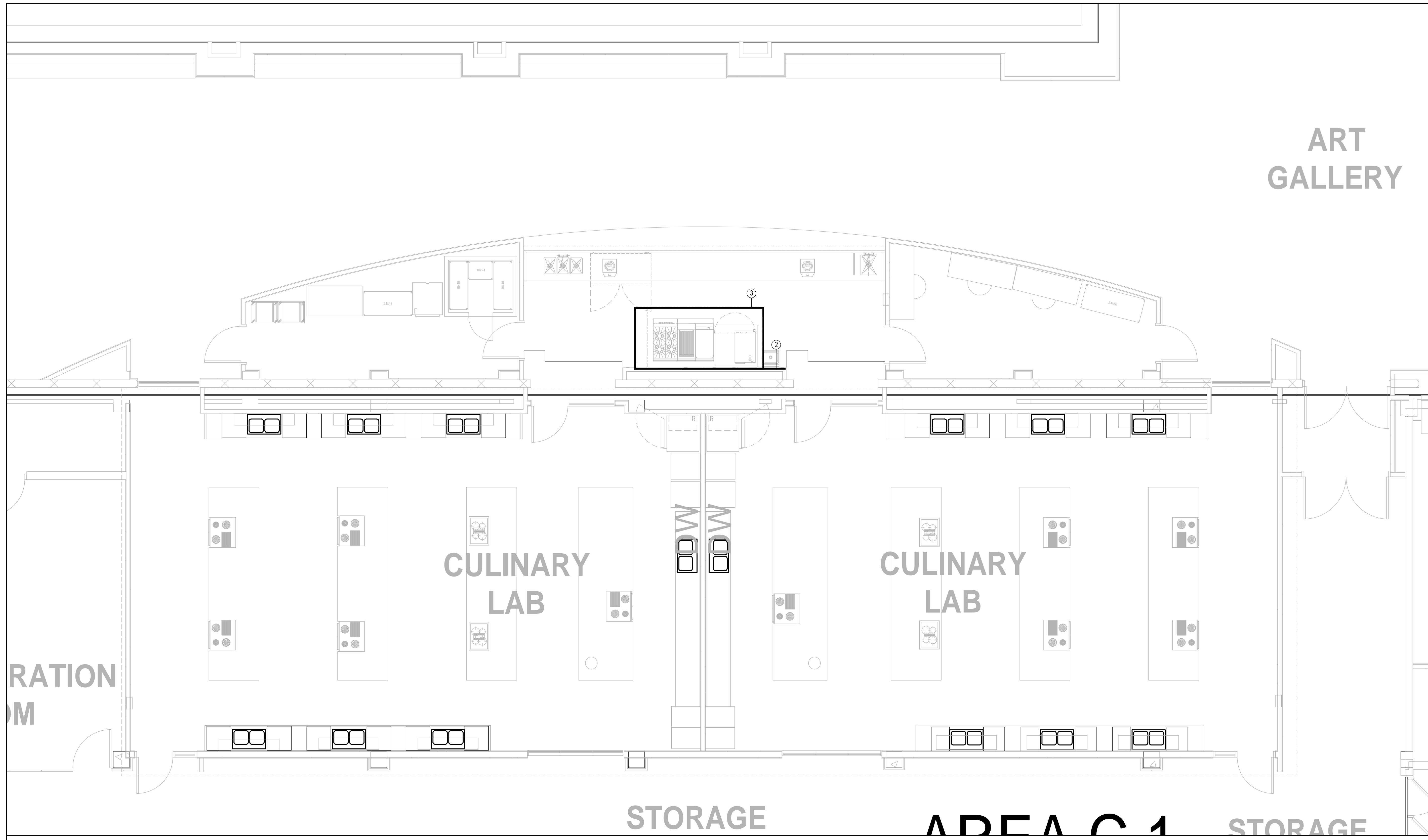

SPECIAL CONDITIONS LAYOUT NOTES

GENERAL DIVISION:

1. PROPERLY REINFORCE ALL WALLS AND/OR CEILINGS TO SUPPORT ALL WALL AND/OR CEILING SUPPORTED EQUIPMENT. ALL WALL BLOCKING TO BE MINIMUM 3/4" MARINE GRADE PLYWOOD OR 14 GAUGE GALVANIZED STEEL. WALL BLOCKING LENGTHS SHOWN ARE MINIMUM AND WALL BLOCKING SHALL ALWAYS EXTEND TO NEXT STUD OVER IN EACH DIRECTION.
2. PROVIDE BOX OUT IN CEILING GRID LAYOUT FOR EXHAUST SYSTEM HOODS AS SHOWN. (REFER TO EXHAUST VENTILATION SYSTEM DRAWINGS FOR MORE INFORMATION)



Kitchen & Servery Renovation Drawings For:
Downers Grove South
 1436 Norfolk St., Downers Grove, Illinois 60516

ISSUED FOR DESIGN DEVELOPMENT - PHASE B

Foodservice Consultant:
 Reitano Design Group
 302 N. East Street - Studio One
 Indianapolis, Indiana 46202
 T - (317) 637-3204

FOODSERVICE
 EQUIPMENT
 SPECIAL CONDITIONS
 LAYOUT

Project Number 2018-025
 Date June 7, 2019
 Drawn By CW
 Checked By RDG

K102

Scale 1/4" = 1'-0"

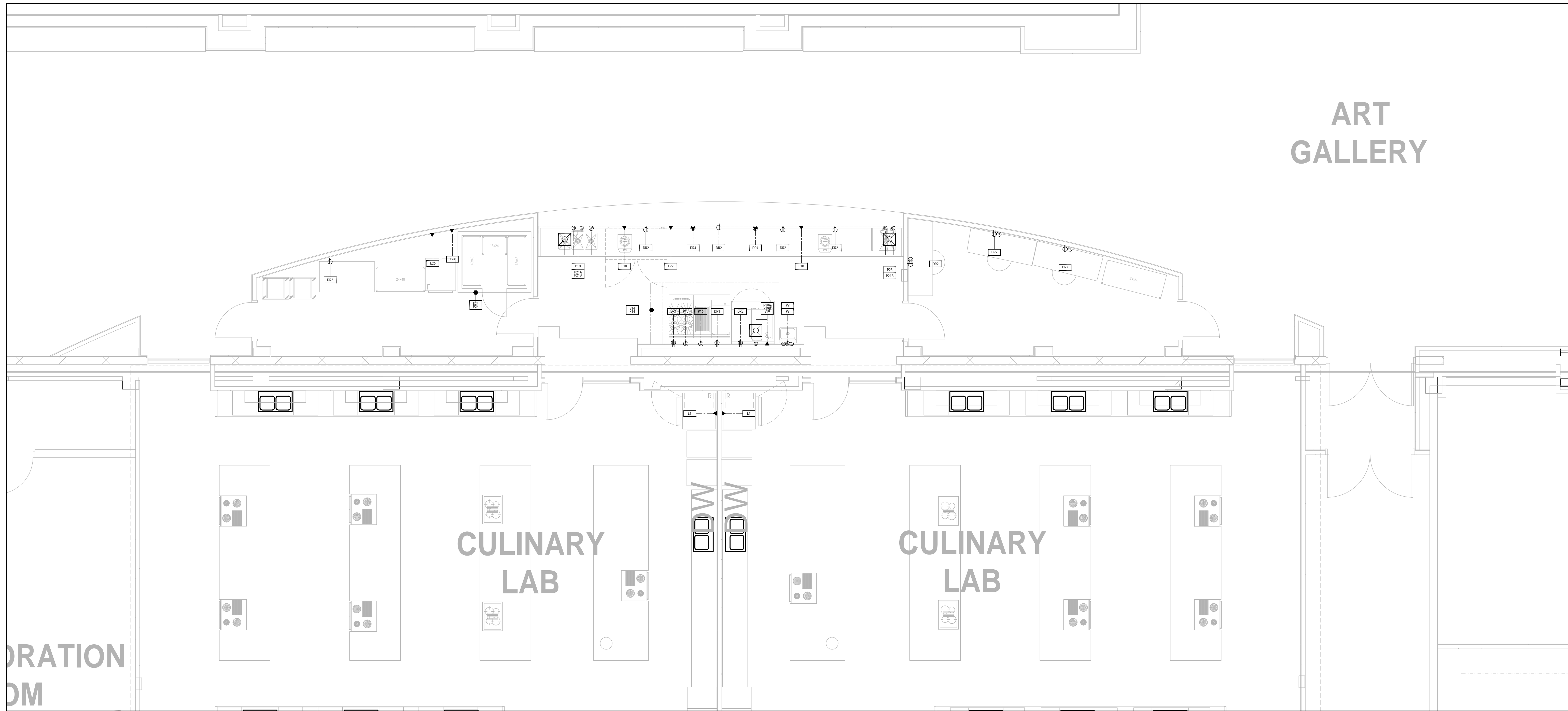

PLUMBING NOTES

- FOODSERVICE SPOT LOCATION SCHEDULES & DRAWINGS ARE FOR REFERENCE AND BIDDING PURPOSES. TO BE USED ONLY AS A GUIDE FOR FOOD SERVICE EQUIPMENT ELECTRICAL, PLUMBING & VENTILATION SPOT LOCATIONS AND ARE NOT APPROVED FOR USE ON THE JOB SITE FOR ROUGH-IN PURPOSES. THE KITCHEN EQUIPMENT CONTRACTOR SHALL BE RESPONSIBLE FOR CREATING HIS/HER OWN ROUGH-IN SCHEDULES & DRAWINGS SHOWING ACCURATE LOCATIONS FOR UTILITIES AND WORK TO BE INSTALLED IN ACCORDANCE WITH ALL FEDERAL, STATE & LOCAL CODES.
- ALL SPOT LOCATIONS SHOWN ON THESE DRAWINGS ARE SPECIFIC TO THE EQUIPMENT SHOWN ON THE FOODSERVICE EQUIPMENT PLAN. REFER TO ARCHITECTURAL & PLUMBING DRAWING SETS FOR ADDITIONAL PLUMBING REQUIREMENTS NOT SHOWN.
- ALL FLOOR AREAS IN THE KITCHEN & SERVING SPACE SHALL BE "TRANSIT LEVEL". DO NOT SLOPE FLOOR TO FLOOR DRAINS OR FLOOR SINKS IN THIS AREA!!!
- MECHANICAL DIVISION TO INSTALL ALL FAUCET ASSEMBLIES, PRE-RINSE SPRAY ASSEMBLIES, HOSE ASSEMBLIES, VACUUM BREAKERS, CHECK VALVES, FLOW CONTROL VALVES, SOLENOID VALVES, WATER PRESSURE REDUCING VALVES, GAS PRESSURE REDUCING VALVES, TEMPERATURE GAUGES, PRESSURE GAUGES, WATER HAMMER SHOCK ABSORBERS & WATER FILTRATION SYSTEMS FURNISHED BY THE KITCHEN EQUIPMENT CONTRACTOR.
- MECHANICAL DIVISION TO FURNISH & INSTALL ALL WATER, GAS & STEAM SUPPLY LINES, DRAIN MANIFOLDS & TAILPIECES, TRAPS, SHUT-OFF VALVES, VENT PIPING, GAS SUPPLY LINE STRAINERS/FILTERS, BACK FLOW PREVENTION DEVICES, FLOOR DRAINS & FLOOR SINKS AS REQUIRED FOR EQUIPMENT INSTALLATION AND ANY CODE REQUIREMENTS. ALL SUPPLY LINES SERVICING EQUIPMENT ADJACENT TO AN EXTERIOR WALL ARE TO BE RAN ALONG INTERIOR FACE OF WALL TO AVOID POTENTIAL FREEZING.
- MECHANICAL DIVISION TO FURNISH & INSTALL STAINLESS STEEL OR CHROME PLATED BRASS ESCUTCHEONS OR FLANGES FOR UTILITY LINES WHICH EXTEND THROUGH BUILDING WALLS AND EQUIPMENT. ALL PENETRATIONS TO BE SEALED WATER-TIGHT AND VERMIN PROOF.
- MECHANICAL DIVISION TO FURNISH & INSTALL TYPE "L" COPPER TUBING DRAIN LINES FROM ALL APPLICABLE EQUIPMENT TO FLOOR SINKS (INCLUDING WALK-IN COOLERS AND FREEZER COILS) AND TO INSULATE ALL DRAIN LINES FROM ICE BINS, REFRIGERATION EQUIPMENT ETC. MECHANICAL DIVISION TO INSTALL DRAIN LINES SO THEY DO NOT AFFECT UNDERCOUNTER STORAGE AND OTHER OPERATIONAL FUNCTIONS OF THE FIXTURES.
- MECHANICAL DIVISION TO FURNISH & INSTALL CHROME PLATED PIPING ON ALL EXPOSED PIPING ABOVE COUNTER HEIGHT OR IN "DIRECT" LINE OF SIGHT TO THE OWNER/OPERATOR.
- MECHANICAL DIVISION TO FURNISH & INSTALL ALL 1/2"x1/2" FLOOR SINKS WITH HALF GRATES. FLOOR SINKS TO BE MOUNTED IN FLOOR SLUGH THAT THE TOP OF THE RIM WILL BE FLUSH WITH FINISHED FLOOR ELEVATION UNLESS OTHERWISE DIRECTED BY STATE & LOCAL CODES. FLOOR SINKS FOR DISHWASHERS AND ALL COOKING EQUIPMENT TO HAVE A MINIMUM OF 3" DRAIN CONNECTION.
- MECHANICAL DIVISION TO COOL, HEAT &/OR VENTILATE FOOD SERVICE DRY STORAGE ROOM TO MAINTAIN A TEMPERATURE OF 68 DEGREES TO 72 DEGREES YEAR AROUND.
- MECHANICAL DIVISION TO UTILIZE EXISTING FLOOR DRAINS, FLOOR SINKS, DIRECT PLUMBING DRAINS, GAS CONNECTIONS & WATER CONNECTIONS WHERE POSSIBLE FOR NEW EQUIPMENT AND CAP OFF ANY EXISTING SERVICES MADE OBSOLETE BY THESE DRAWINGS.



Kitchen & Servery Renovation Drawings For:

Downers Grove South

1436 Norfolk St., Downers Grove, Illinois 60516

ELECTRICAL NOTES

- FOODSERVICE SPOT LOCATION SCHEDULES & DRAWINGS ARE FOR REFERENCE AND BIDDING PURPOSES. TO BE USED ONLY AS A GUIDE FOR FOOD SERVICE EQUIPMENT ELECTRICAL, PLUMBING & VENTILATION SPOT LOCATIONS AND ARE NOT APPROVED FOR USE ON THE JOB SITE FOR ROUGH-IN PURPOSES. THE KITCHEN EQUIPMENT CONTRACTOR SHALL BE RESPONSIBLE FOR CREATING HIS/HER OWN ROUGH-IN SCHEDULES & DRAWINGS SHOWING ACCURATE LOCATIONS FOR UTILITIES AND WORK TO BE INSTALLED IN ACCORDANCE WITH ALL FEDERAL, STATE & LOCAL CODES.
- ALL SPOT LOCATIONS SHOWN ON THESE DRAWINGS ARE SPECIFIC TO THE EQUIPMENT SHOWN ON THE FOODSERVICE EQUIPMENT PLAN. REFER TO ARCHITECTURAL & ELECTRICAL DRAWING SETS FOR ADDITIONAL ELECTRICAL REQUIREMENTS NOT SHOWN.
- ELECTRICAL AMPERAGE NOTED IN SCHEDULE INDICATES AMP "DRAW" & NOT CIRCUIT BREAKER SIZE UNLESS OTHERWISE NOTED. ELECTRICAL DIVISION IS RESPONSIBLE FOR PROPER CIRCUIT BREAKER SIZING.
- ELECTRICAL DIVISION TO VERIFY ALL FOODSERVICE EQUIPMENT WITH DIRECT ELECTRICAL CONNECTION TO BE IN LINE OF SIGHT OF KITCHEN ELECTRICAL DISTRIBUTION PANEL AND IF NOT, ELECTRICAL DIVISION TO FURNISH & INSTALL A FUSED QUICK DISCONNECT ADJACENT TO EQUIPMENT.
- ELECTRICAL DIVISION TO INSTALL ALL CONTROL PANELS, STARTERS, SOLENOID VALVES, JUNCTION BOXES & DISCONNECT SWITCHES FURNISHED BY THE KITCHEN EQUIPMENT CONTRACTOR.
- ELECTRICAL DIVISION TO FURNISH & INSTALL ALL WIRING, ELECTRICAL OUTLETS, STARTERS, JUNCTION BOXES, DISCONNECT SWITCHES & CONDUIT REQUIRED FOR EQUIPMENT INSTALLATION IN ACCORDANCE WITH MANUFACTURER'S SPECIFICATIONS & ELECTRICAL CODE REQUIREMENTS. ELECTRICAL RECEPTACLES TO BE FLUSH MOUNTED UNLESS OTHERWISE NOTED.
- ELECTRICAL DIVISION TO FURNISH & INSTALL GROUNDING WIRE TO ALL FOOD SERVICE EQUIPMENT IN ADDITION TO THE NUMBER OF WIRES NOTED IN INDIVIDUAL SERVICES.
- ELECTRICAL DIVISION TO FURNISH & INSTALL GROUND FAULT PROTECTION FOR ANY RECEPTACLE WITHIN THE KITCHEN & SERVING AREAS.
- ELECTRICAL DIVISION TO FURNISH & INSTALL SHUNT TRIP BREAKERS FOR ALL ELECTRICAL SERVICE TO EQUIPMENT UNDER EXHAUST HOODS WHEN FIRE SUPPRESSION SYSTEM IS REQUIRED.
- ELECTRICAL DIVISION TO FURNISH 6"-0" PIGTAIL FLEX CONDUIT AT ALL DIRECT CONNECTION STUB-OUTS AND EXTEND TO FINAL CONNECTION ON EQUIPMENT. ELECTRICAL DIVISION TO PROVIDE CAPS AND CORDS FOR ALL ITEMS WHICH USE CONVENIENCE OUTLETS WHEN NOT SUPPLIED BY THE MANUFACTURER AND SHORTEN ANY CORDS IF NECESSARY.
- ELECTRICAL DIVISION TO UTILIZE EXISTING ELECTRICAL CONNECTIONS WHERE POSSIBLE FOR NEW EQUIPMENT AND CAP OFF ANY EXISTING SERVICES MADE OBSOLETE BY THESE PLANS.

ISSUED FOR DESIGN DEVELOPMENT - PHASE B
Foodservice Consultant:
Reitano Design Group
302 N. East Street - Studio One
Indianapolis, Indiana 46202
T - (317) 637-3204

FOODSERVICE
EQUIPMENT
SPOT LOCATIONS
AND SCHEDULES

Project Number 2018-025
Date June 7, 2019
Drawn By CW
Checked By RDG

K200

Scale 1/4"=1'-0"

FOODSERVICE EQUIPMENT ELECTRICAL SCHEDULE

ITEM	EQUIPMENT DESCRIPTION	MARK	VOLTAGE	PHS	KW	AMP	HP	CONN	AFF	REMARKS	
1	SINGLE DOOR ROLL-IN REFRIGERATOR	E1	120	1		10.6	0.33	PLUG	86		
14	KITCHEN EXHAUST SYSTEM	E14	REFER TO EXHAUST VENTILATION SYSTEM DRAWING K600								
18	INDUCTION WARMER	E18	208	1		16.0		PLUG	42	VERIFY REQUIREMENTS WITH EXISTING EQUIPMENT	
19	COUNTERTOP COMBI/STEAMER	E19	208	3		23.6		PLUG	42		
22	UNDERCOUNTER REFRIGERATOR	E22	120	1		4.0	0.25	PLUG	18		
24	WALK-IN COOLER LIGHTS AND DOOR HEATER	E24A	120	1		4.0		DIRECT	DFA		
	WALK-IN COOLER COMPRESSOR	E24A	120	1		14.3	0.50	PLUG	96		
26	SINGLE DOOR REACH-IN FREEZER	E26	120	1		9.7	0.50	PLUG	86	VERIFY REQUIREMENTS WITH EXISTING EQUIPMENT	
	DUPLEX CONVENIENCE RECEPTACLE	DR1	120	1		16.0			16		
	DUPLEX CONVENIENCE RECEPTACLE	DR2	120	1		16.0			42	FURNISH HORIZONTAL RECEPTACLE WHEN MOUNTED ABOVE COUNTERTOP	
	SPECIAL PURPOSE RECEPTACLE	DR4	208	1		30.0			42	FURNISH HORIZONTAL RECEPTACLE WHEN MOUNTED ABOVE COUNTERTOP	

FOODSERVICE EQUIPMENT PLUMBING SCHEDULE

ITEM	EQUIPMENT DESCRIPTION	MARK	WATER			WASTE			GAS			REMARKS
			HW	CW	AFF	CONN	SIZE	AFF	SIZE	MBTU	AFF	
8	HAND SINK FAUCET	P8	0.5	0.50	20							EXTEND SERVICE TO EQUIPMENT MOUNTED FAUCET
9	WALL MOUNTED HAND SINK	P9				DIRECT	1.50	14				EXTEND DRAIN LINE FROM SINK TO DIRECT DRAIN
10	DECK MOUNTED FAUCET	P10	0.5	0.50	14							EXTEND SERVICE TO EQUIPMENT MOUNTED FAUCET
14	KITCHEN EXHAUST SYSTEM	P14	REFER TO EXHAUST VENTILATION SYSTEM DRAWING K600									
15	FOUR BURNER RANGE WITH OVEN	P15							1.00	140.0	12	EXTEND GAS SERVICE TO EQUIPMENT THRU KEC FURNISHED STATIONARY GAS CONNECTOR KIT.
16	CHARBROILER/GRIDDLE	P16							1.00	78.0	12	EXTEND GAS SERVICE TO EQUIPMENT THRU KEC FURNISHED STATIONARY GAS CONNECTOR KIT.
19	COUNTERTOP COMBI/STEAMER	P19A		0.75	42							EXTEND ONE (1) WATER SERVICE DIRECTLY TO CONDENSATE LINE AND ONE (1) WATER SERVICE TO STEAM LINE THRU KEC FURNISHED WATER FILTER. EXTEND STEAM-RESISTANT DRAIN LINE FROM EQUIPMENT TO FLOOR SINK.
		P19B		0.75	42							
		P19C				INDIRECT	1.50	FLR SNK				
21	WORK TABLE W/SINKS	P21A				DIRECT	2.00	12				MANIFOLD DRAIN LINES FROM WASH AND RINSE SINKS AND EXTEND TO DIRECT DRAIN. EXTEND DRAIN LINE FROM SANITIZE SINK TO FLOOR SINK.
		P21B				INDIRECT	2.00	FLR SNK				
23	DECK MOUNTED FAUCET	P10	0.5	0.50	14							EXTEND SERVICE TO EQUIPMENT MOUNTED FAUCET
	FLOOR DRAIN	FD1				INDIRECT		FL DRN				
	FLOOR SINK	FS1				INDIRECT		FL SNK				

EXHAUST VENTILATION SYSTEM SCHEDULE (ITEM #14)

EXHAUST VENTILATION ELECTRICAL REQUIREMENTS							
ITEM	EQUIPMENT DESCRIPTION	VOLTAGE	PHS	AMP	HP	AFF	REMARKS
E14	COOKING VENTILATION HOOD	120	1	16.0		DFA	SEE NOTES
E14A	FIRE SUPPRESSION SYSTEM	120	1	16.0		DFA	SEE NOTES
E14B	COOKING EXHAUST FAN	208	3	6.3	1.50	ROOF	SEE NOTES
E14C	COOKING SUPPLY FAN	208	3	7.5	2.00	ROOF	SEE NOTES

EXHAUST VENTILATION MECHANICAL REQUIREMENTS						
ITEM	EQUIPMENT DESCRIPTION	CFM REQ.	WEIGHT (LBS)	GAS	BTU	REMARKS
P14	COOKING VENTILATION HOOD		713			SEE NOTES
P14A	COOKING EXHAUST FAN	2,850	171			SEE NOTES
P14B	COOKING SUPPLY FAN	2,280	510	1/2"	181,944	SEE NOTES

EXHAUST VENTILATION WORK BY OTHERS						
ITEM	EQUIPMENT	MAKE-UP AIR BALANCE REQUIRED BY BUILDING HVAC RESOURCES (CFM)	ROOF OPENING BY G.C.	EXHAUST FAN	SUPPLY FAN	REMARKS
14	EXHAUST VENTILATION SYSTEM	570	26.0' X 26.0'		26.0' X 26.0'	

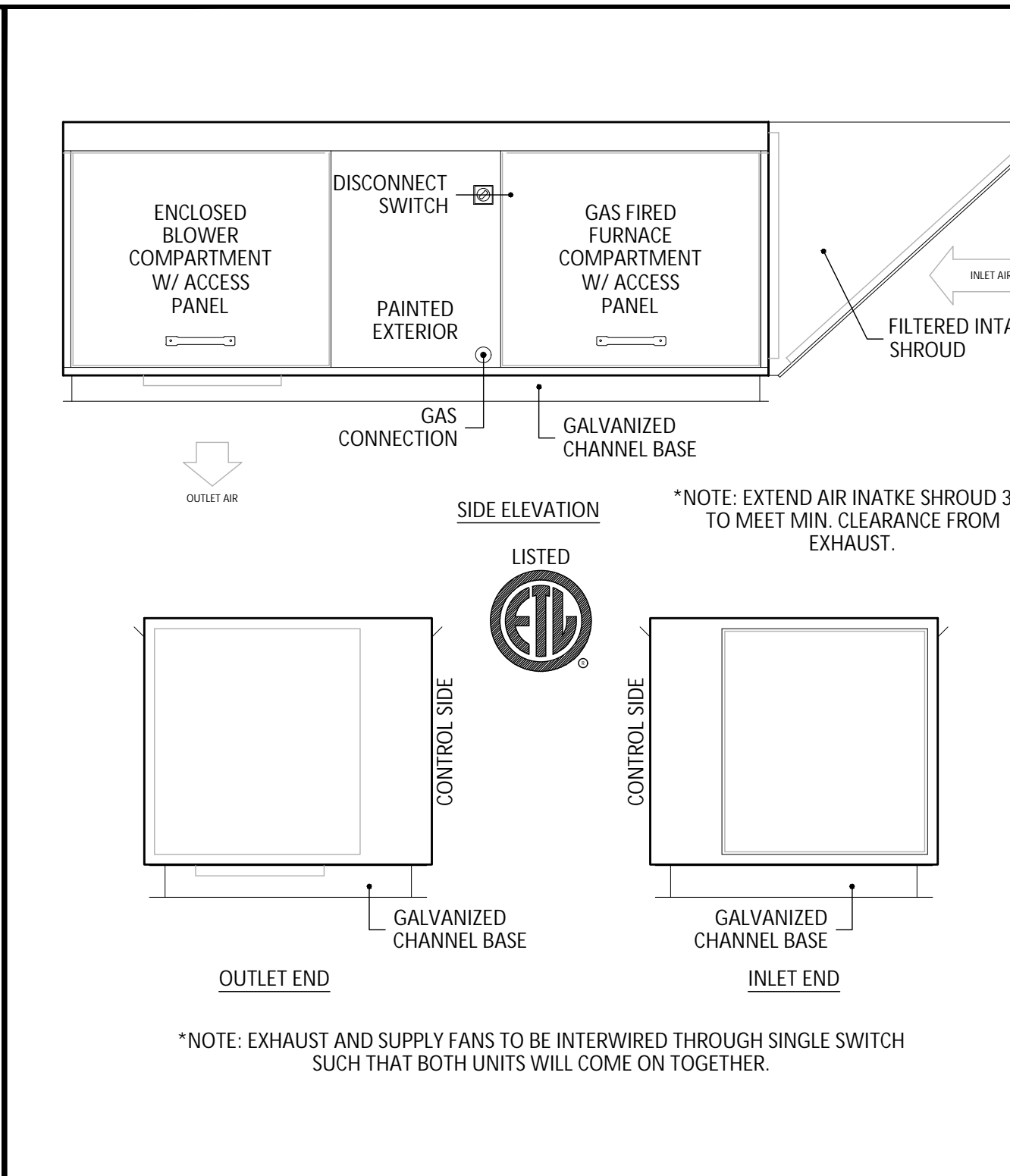
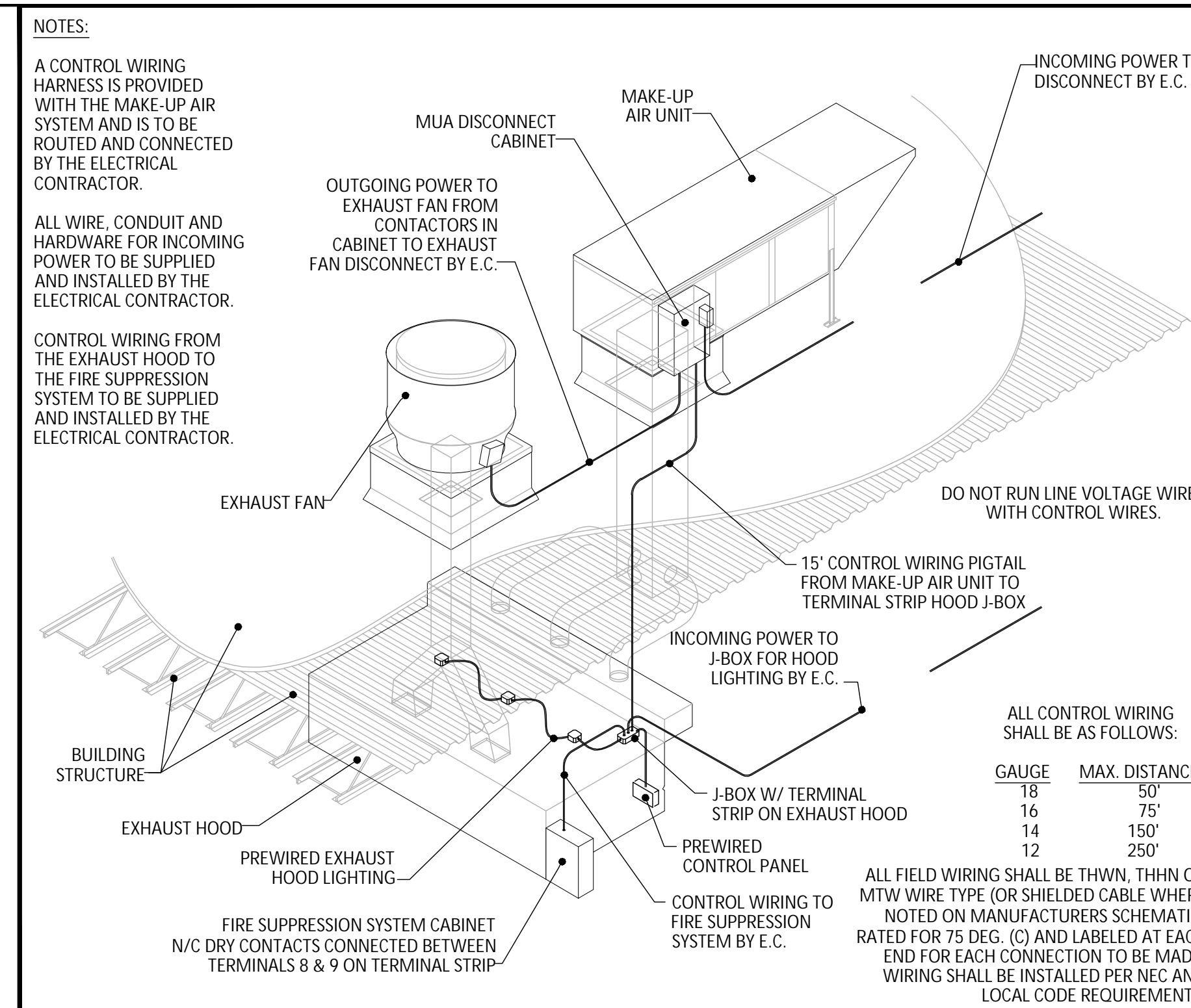

TYPICAL WIRE ROUTING DETAIL NOT TO SCALE B MAKE-UP AIR UNIT DETAIL NOT TO SCALE A

EXHAUST VENTILATION RESPONSIBILITIES BY OTHER TRADES

GENERAL DIVISION:
 PROVIDE DUCT SHAFT(S) OPENING(S) THRU WALLS, CEILINGS AND ROOF FOR EXHAUST AND MAKE-UP AIR DUCTS. COORDINATE JOIST OR STRUCTURAL MEMBER INSTALLATION TO PROVIDE REQUIRED CLEARANCES FOR DUCTWORK AND SHAFT ASSEMBLIES. GENERAL CONTRACTOR TO VERIFY DUCT CONFIGURATION, INSTALLATION AND ACCESS FOR CONNECTION OF EXHAUST DUCT TO HOOD PRIOR TO CONSTRUCTION OF DUCT SHAFT(S).

GENERAL CONTRACTOR TO PROVIDE RATED ACCESS DOORS AND/OR PANELS AT ALL DUCT TURNS AND HORIZONTAL DUCT RUNS IN EXCESS OF 10'-0" INTERVALS. ACCESS TO BE PROVIDED IN BOTH SHAFT AND DUCT.

PROVIDE ROOF DECK OPENINGS, SET-IN-PLACE AND FLASH (WITH CANT) ROOF CURBS AND EQUIPMENT SUPPORT RAIL FURNISHED BY THE HOOD SYSTEM MANUFACTURER. VERIFY HEIGHTS OF ROOFTOP EQUIPMENT AS IT RELATES TO ROOF PARAPET WALLS OR SCREENS REQUIRED BY ALL GOVERNING AGENCIES.

ELECTRICAL DIVISION:
 KITCHEN EXHAUST WORK: PROVIDE 120/60/1 20 AMP CIRCUIT, FOR HOOD LIGHTS AND CONTROLS TO JUNCTION BOX ON TOP OF HOOD. PROVIDE CIRCUIT (FOR FAN MOTOR) TO DISCONNECT SWITCH MOUNTED ON EXTERIOR OF EXHAUST FAN CABINET. EXTEND POWER WIRING FROM MOTOR STARTER TO CONNECTION POINT ON EXHAUST FAN. PROVIDE CONDUIT AND FOUR WIRES FROM TERMINAL BLOCK ON EXHAUST HOOD TO EXHAUST FAN MOTOR STARTER PANEL. PROVIDE CONDUIT AND THREE WIRES FROM TERMINAL BLOCK ON HOOD TO MICRO-SWITCH OF FIRE PROTECTION SYSTEM. PROVIDE AND INSTALL AN OCTAGON BOX FOR THE FIRE SYSTEM PULL STATION. MOUNTING THE CENTERLINE OF THE BOX AT 42" ABOVE THE FINISHED FLOOR. RUN 1/2" CONDUIT FROM THE TOP OF THE BOX TO 6" ABOVE THE CEILING. PULL STATION TO BE PROVIDED WITH FIRE SYSTEM. PROVIDE AND INSTALL AUTOMATIC POWER SHUT-OFF DEVICES (SHUNT TRIP BREAKERS OR DEFINITE PURPOSE CONTACTORS) WITH INTERLOCK TO FIRE SYSTEM MICRO SWITCH, SHUTTING OFF ALL POWER BELOW THE HOOD (INCLUDING CONTROL VOLTAGE) IN THE EVENT OF FIRE SYSTEM ACTUATION. THIS WORK MUST BE IN ACCORDANCE WITH N.E.C., I.A.C. AND THE I.E.C.

DISHMACHINE EXHAUST WORK: FURNISH POWER TO ROOFTOP UNIT AS INDICATED ON HOOD SYSTEM DRAWINGS TO INCLUDE: INTERCONNECT WITH DISHMACHINE FAN CONTROLLER AND SINGLE PHASE POWER FOR MOTOR AS REQUIRED. FURNISH CONNECTION 120/60/1 CONTROL WIRING BETWEEN FAN AND CONTROLLER.

MECHANICAL DIVISION:
 PROVIDE NET ROOM AIR DEMAND AS INDICATED ON THE HOOD SYSTEM DRAWINGS. THIS AIR VOLUME IS REQUIRED ONLY WHEN HOOD SYSTEM IS IN OPERATION. PROVIDE NORMAL HEATING AND COOLING OF THE KITCHEN AREA. INSTALL GAS VALVE SUPPLIED WITH THE FIRE SUPPRESSION SYSTEM IN THE MAIN SUPPLY LINE SERVING THE COOKING EQUIPMENT TO SHUT-OFF GAS SERVICE TO THE COOKING EQUIPMENT IN THE EVENT OF FIRE SYSTEM ACTUATION. PROVIDE AND INSTALL SERVICE TO GAS FIRED FURNACE ON BUILDING ROOF.

EXHAUST VENTILATION RESPONSIBILITIES BY OTHER TRADES NOT TO SCALE E

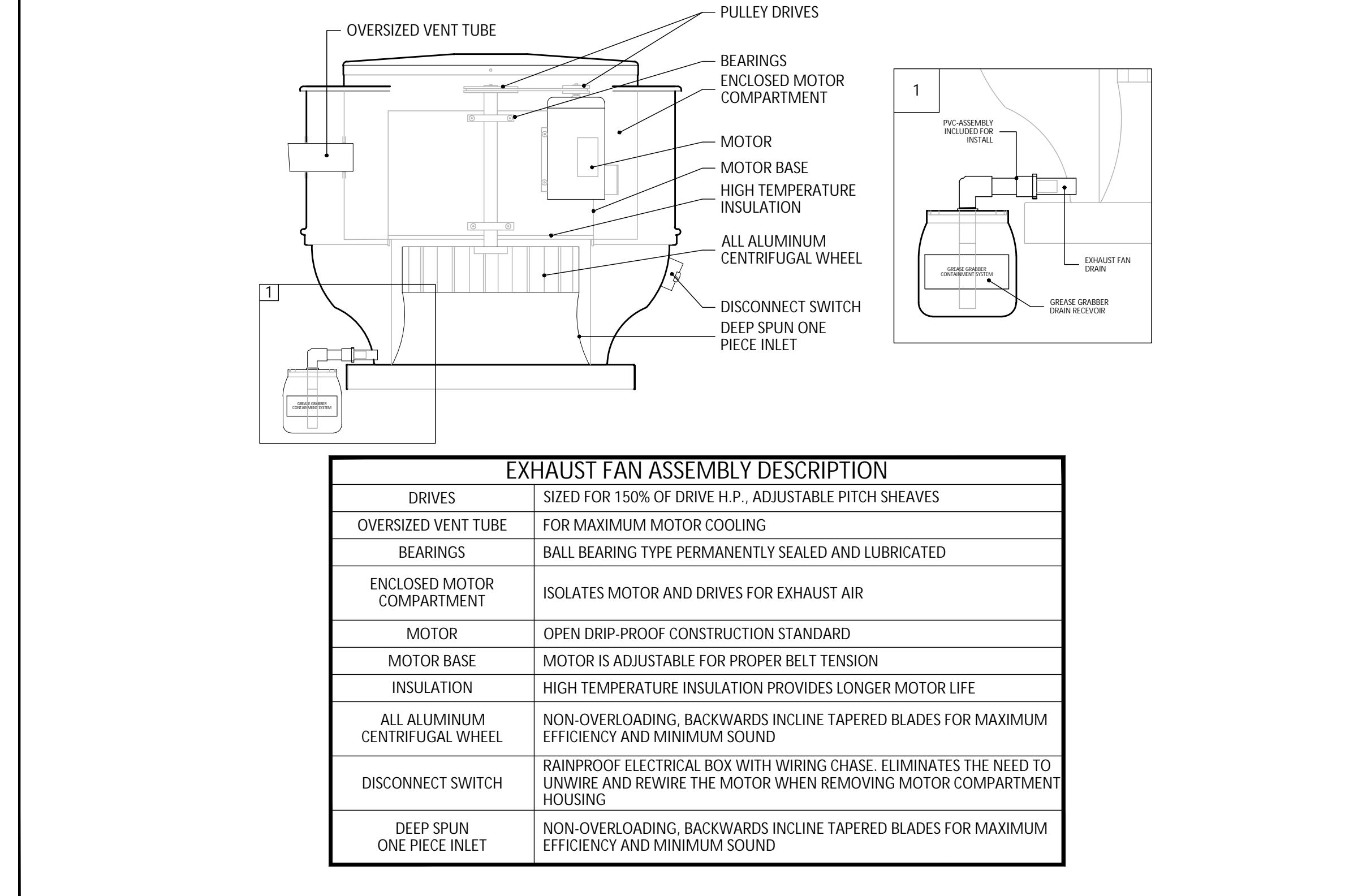

UPBLAST EXHAUST FAN DETAIL NOT TO SCALE E

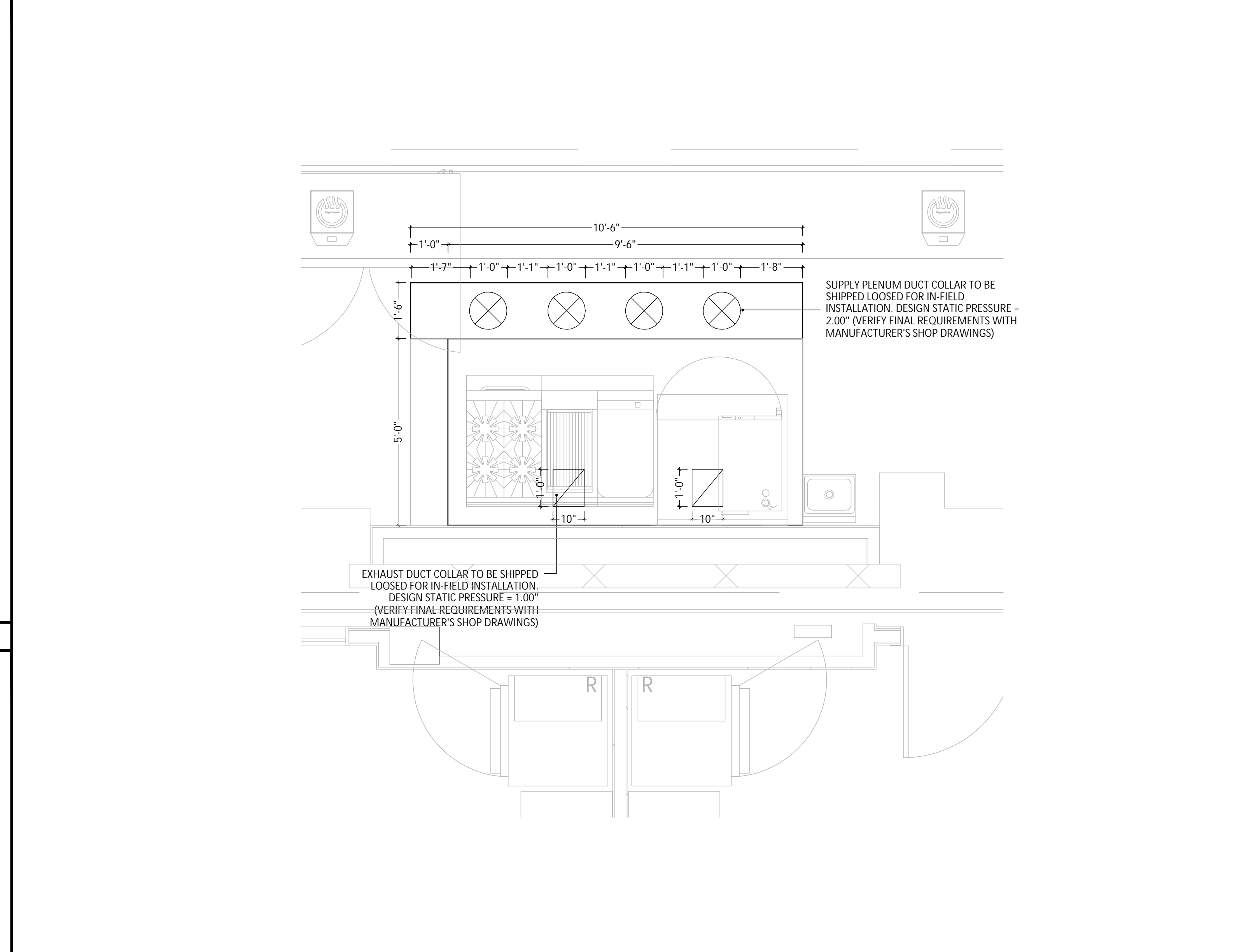

EXHAUST HOOD LAYOUT SCALE 1/4" = 1'-0" C

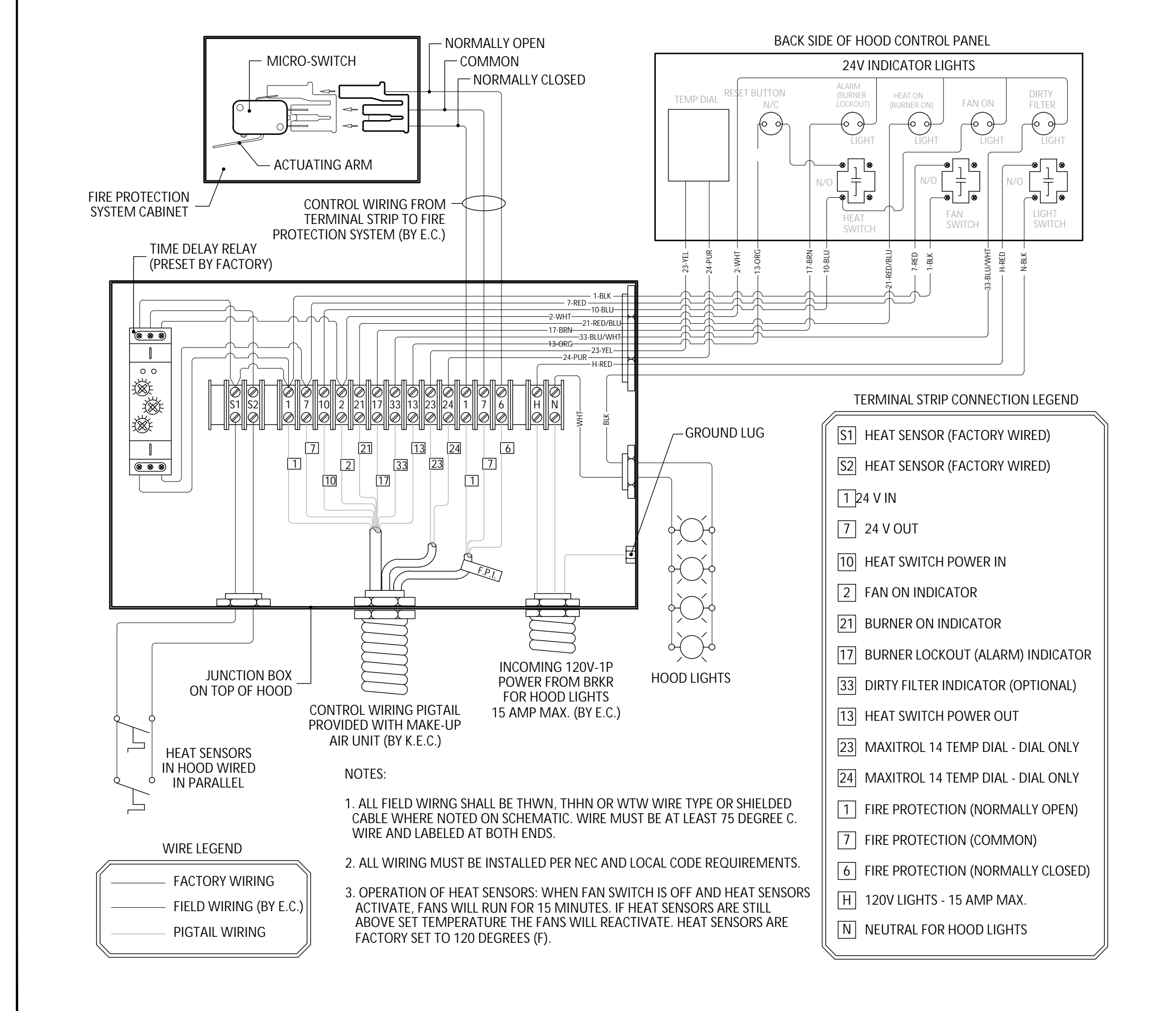

TYPICAL WIRING CONNECTION DETAIL NOT TO SCALE F

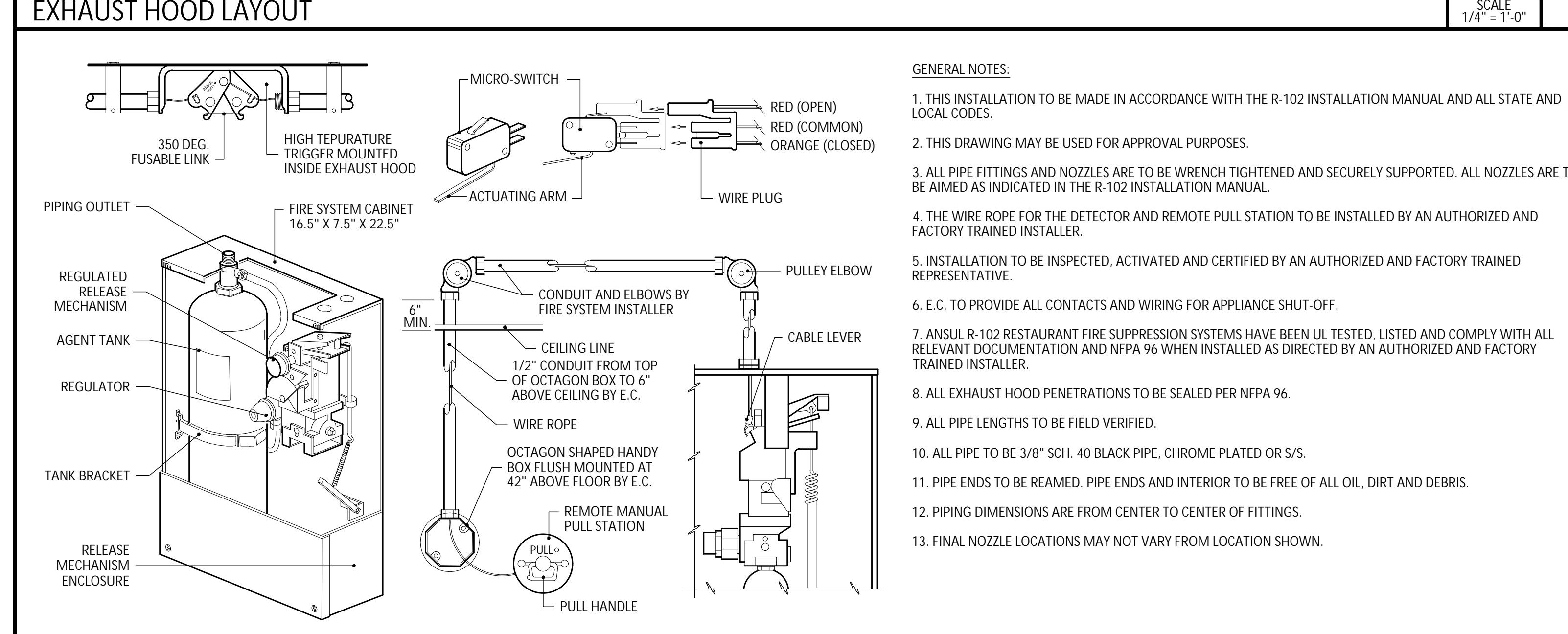

FIRE SUPPRESSION SYSTEM DETAIL NOT TO SCALE D

EXHAUST VENTILATION NOTES

- MECHANICAL EXHAUST SYSTEM TO BE PROVIDED OVER ALL COOKING EQUIPMENT, WITH MINIMUM OVERHANG AS REQUIRED BY ALL GOVERNING AGENCIES.
- MECHANICALLY INDUCED MAKE-UP AIR MUST BE PROVIDED FOR COOKING AND DISH WASHING EXHAUST HOOD(S) IN CONJUNCTION WITH H.V.A.C. SYSTEMS IN ORDER TO REPLACE 100% OF EXHAUSTED AIR. MAKE-UP AIR SHALL BE DELIVERED IN THE PROXIMITY OF THE EXHAUST HOOD IN A MANNER NOT TO CREATE UNDESIRABLE TURBULENCE IN THE WORKING AREAS.
- MAKE-UP AIR INTAKE MUST CLEAR EXHAUST AIR DISCHARGE BY A MINIMUM OF 10'-0".
- ALL HORIZONTAL DUCT RUNS REQUIRE MINIMUM 1/4"/FT. SLOPE TOWARD EXHAUST HOOD. (VERIFY WITH LOCAL CODES)
- EXHAUST AND MAKE-UP AIR SYSTEMS MUST BE INTERLOCKED FOR SIMULTANEOUS OPERATION EXCEPT IN THE CASE OF EMERGENCY AS MANDATED BY THE FIRE MARSHALL.

ALL EXHAUST FANS, SUPPLY FANS AND MAKE-UP AIR UNITS TO BE LOCATED ON THE SECOND STORY ROOF LOCATED ABOVE A PORTION OF THE KITCHEN AREA.

REFER TO ARCHITECTURAL AND STRUCTURAL DRAWING SETS FOR FURTHER INFORMATION AND COORDINATION OF REQUIRED LENGTHS OF ANY EXHAUST/SUPPLY DUCTWORK.

Kitchen & Severy Renovation Drawings For:

Downers Grove South

1436 Norfolk St., Downers Grove, Illinois 60516

ISSUED FOR DESIGN DEVELOPMENT - PHASE B

Foodservice Consultant:
 Reitano Design Group
 302 N. East Street - Studio One
 Indianapolis, Indiana 46202
 T - (317) 637-3204

FOODSERVICE EQUIPMENT
 EXHAUST VENTILATION
 SYSTEM DRAWING, DETAILS &
 SCHEDULES

Project Number 2018-025

Date June 7, 2019

Drawn By CW

Checked By RDG

K600

Scale 1/4" = 1'-0"

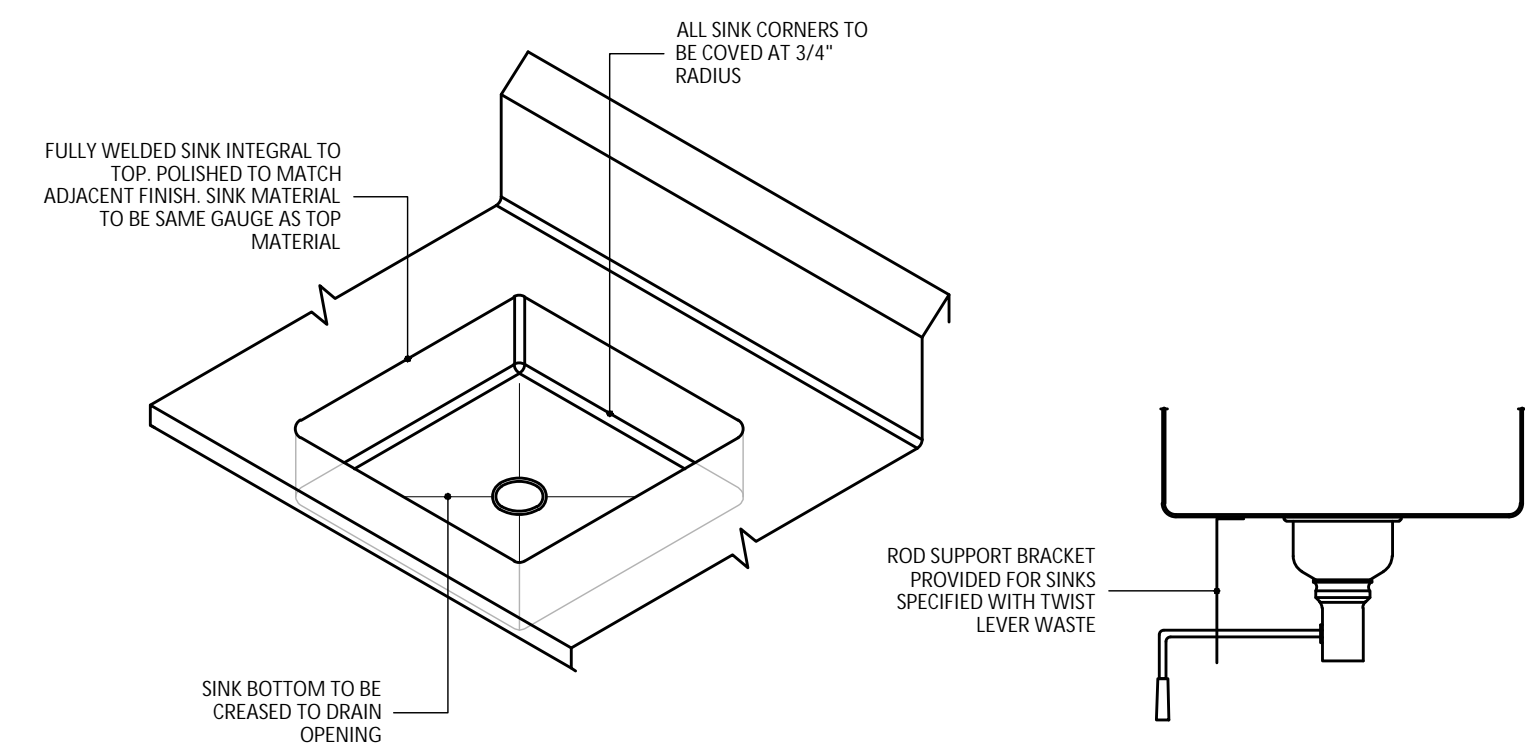

STAINLESS STEEL SINK CONSTRUCTION DETAIL

NOT TO SCALE

D

MARINE EDGE DETAIL

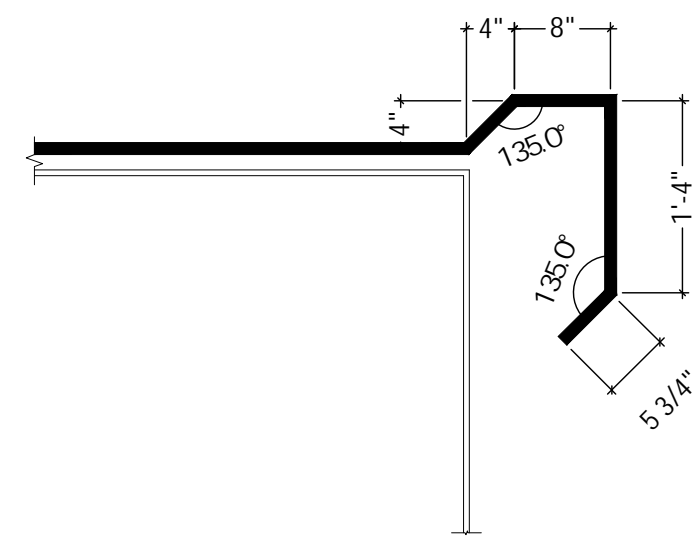

NOT TO SCALE

C

ROLLED RIM DETAIL

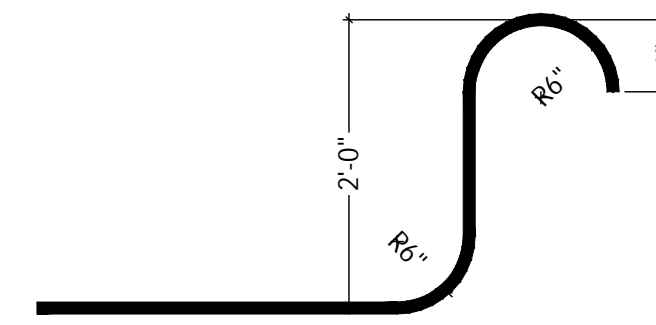

NOT TO SCALE

B

FLAT EDGE DETAIL

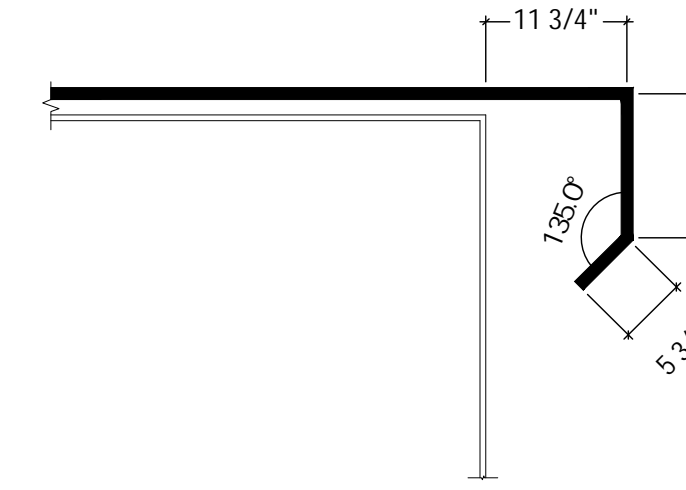

NOT TO SCALE

A

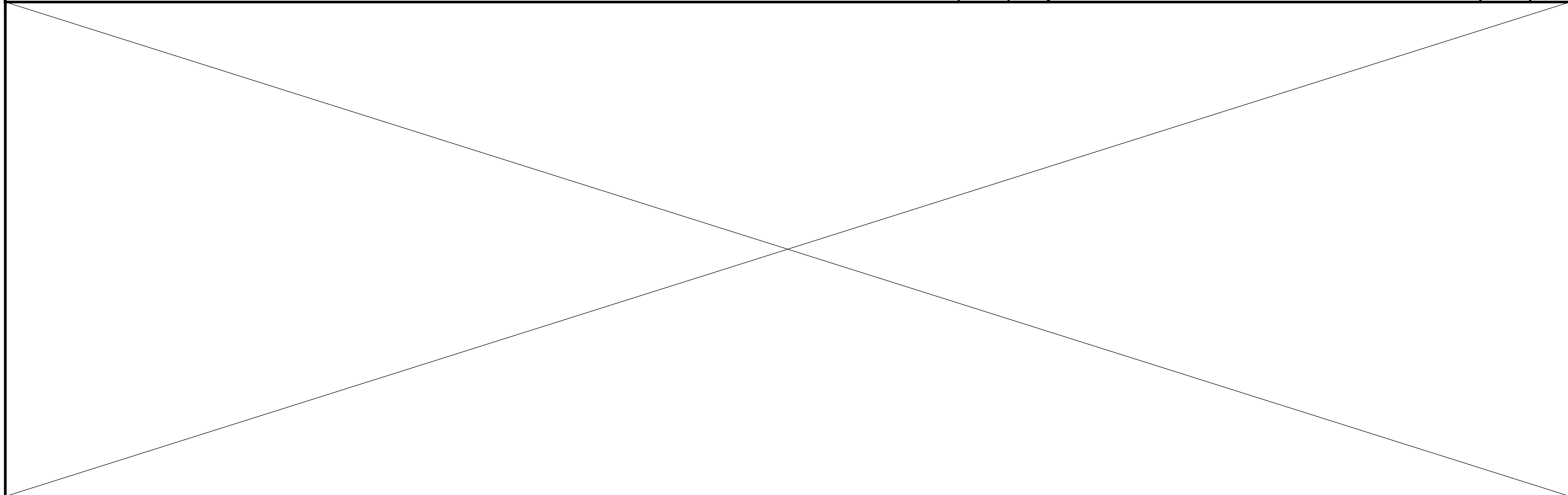

NOT IN USE

NOT TO SCALE

F

FIRE SUPPRESSION SYSTEM MANUAL PULL STATION

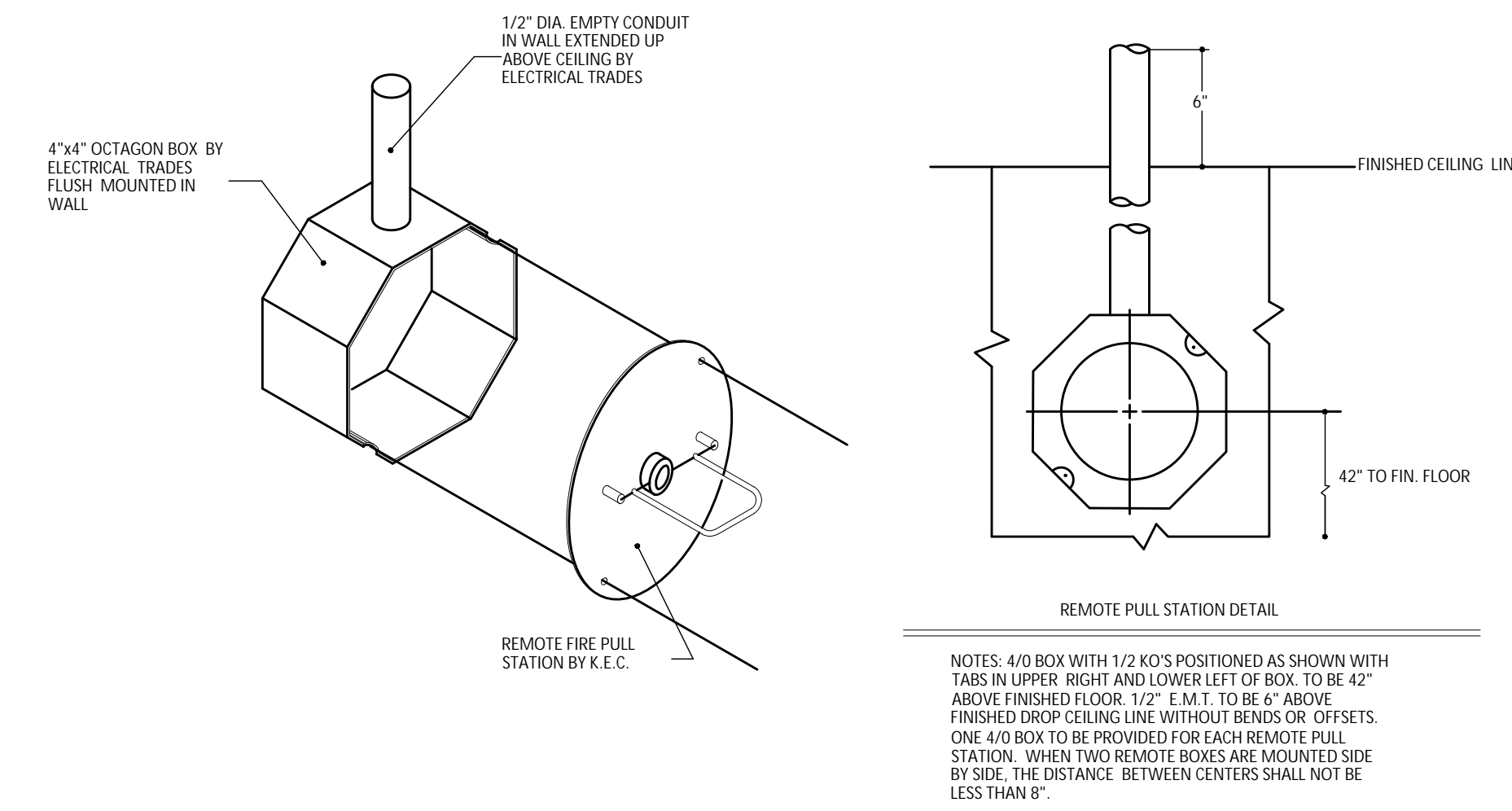

NOT TO SCALE

E

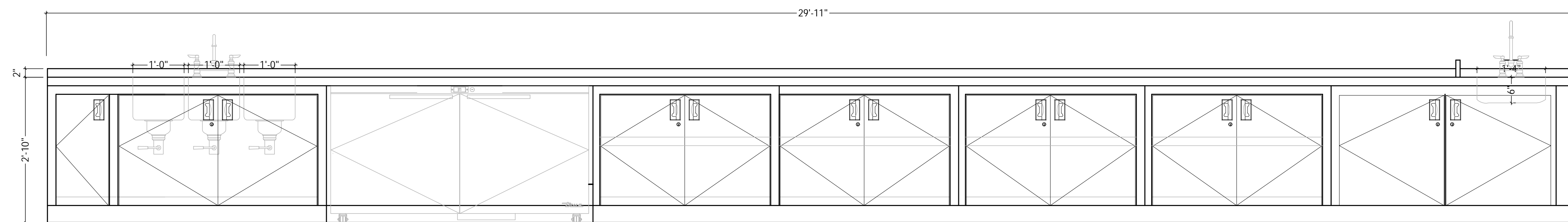

ITEM #21 PREP TABLE

NOT TO SCALE

G



Kitchen & Servery Renovation Drawings For:
Downers Grove South
 1436 Norfolk St., Downers Grove, Illinois 60516

ISSUED FOR DESIGN DEVELOPMENT - PHASE B
 Foodservice Consultant:
 Reitano Design Group
 302 N. East Street - Studio One
 Indianapolis, Indiana 46202
 T - (317) 637-3204

FOODSERVICE
 EQUIPMENT DETAILS,
 ELEVATIONS, AND SECTIONS

Project Number 2018-025
 Date June 7, 2019
 Drawn By CW
 Checked By RDG

K700

Scale 1/4" = 1'-0"