



DATE: June 26, 2019

FROM: Wight & Company
2500 N. Frontage Road
Darien, IL 60561

Wight & Company

wightco.com

.....
2500 North Frontage Road
Darien, IL 60561

.....
P 630.969.7000

F 630.969.7979

SUBJECT: **ADDENDUM #1 TO THE BIDDING DOCUMENTS FOR:
NORTH HIGH SCHOOL BID GROUP #7**
MASTER FACILITY PLAN IMPLEMENTATION
COMMUNITY HIGH SCHOOL DISTRICT 99
NORTH HIGH SCHOOL
4436 MAIN STREET
DOWNERS GROVE, IL 60516

This addendum forms a part of the Bidding Contract Documents, dated June 7, 2019. Bidders must acknowledge receipt of this Addendum in the space provided on the Bid Form.

I. Clarifications

1. None

II. Specifications

1. Section 075323 EPDM ROOFING.
 - Specification re-issued to include provisions for temporary roofing.

III. Drawings

STRUCTURAL

- S2.1B-EP:
 - Added 2" cont. isolation joint in Detail 3
- S2.2B:
 - Changed number of shear studs for 1 beam on Second Floor Framing Plan
 - Deleted a section on Third Floor Framing Plan
 - Added a Grid line and moved 2 beams on Enlarged 2nd Floor Framing Plan
- S2.3B:
 - Deleted on section on Gymnasium And Wrestling Balcony Roof Framing Plan
 - Called out Roof Edge dimensions

- Changed 2 beam size
- Modified 2 notes
- Called out gap between new and existing structure
- Deleted Top of Column requirement
- S2.4B:
 - Modified 1 note
 - Eliminated welded moment connections at 16 locations and revised to all bolted connections
 - Added 1 section cut.
- S3.6B:
 - Modified Details 1,2,3,6
- S3.7B:
 - Modified Details 1
- S3.8B:
 - Modified Details 1,5,9
- S3.9B:
 - Modified Details 5,7,8
- S3.10B:
 - Modified Detail 1
 - Added Detail 13

END OF ADDENDUM

SECTION 075323 - ETHYLENE-PROPYLENE-DIENE-MONOMER (EPDM) ROOFING

PART 1 - GENERAL

1.1 RELATED DOCUMENTS

- A. Drawings and general provisions of the Contract, including General and Supplementary Conditions and Division 01 Specification Sections, apply to this Section.

1.2 SUMMARY

- A. Section Includes:

1. Adhered EPDM membrane roofing system.
2. Substrate board.
3. Vapor retarder/temporary roof.
4. Roof insulation.

- B. Related Requirements:

1. Division 06 Section "Rough Carpentry" for wood nailers, curbs, and blocking.
2. Division 07 Section "Manufactured Roof Expansion Joints" for proprietary manufactured roof expansion-joint assemblies.
3. Division 07 Section "Sheet Metal Flashing and Trim" for metal roof penetration flashings, flashings, and counterflashings.
4. Division 07 Section "Joint Sealants" for joint sealants, joint fillers, and joint preparation.
5. Division 22 Section "Storm Drainage Piping Specialties" for roof drains.

1.3 DEFINITIONS

- A. Roofing Terminology: Refer to ASTM D 1079 and glossary of NRCA's "The NRCA Roofing and Waterproofing Manual" for definition of terms related to roofing work in this Section.

1.4 PREINSTALLATION MEETINGS

- A. Preinstallation Roofing Conference: Conduct conference at Project site.

1. Meet with Owner, Architect, Owner's insurer if applicable, testing and inspecting agency representative, roofing Installer, roofing system manufacturer's representative, deck Installer, and installers whose work interfaces with or affects roofing, including installers of roof accessories and roof-mounted equipment.
2. Review methods and procedures related to roofing installation, including manufacturer's written instructions.

3. Review and finalize construction schedule and verify availability of materials, Installer's personnel, equipment, and facilities needed to make progress and avoid delays.
4. Examine deck substrate conditions and finishes for compliance with requirements, including flatness and fastening.
5. Review structural loading limitations of roof deck during and after roofing.
6. Review base flashings, special roofing details, roof drainage, roof penetrations, equipment curbs, and condition of other construction that will affect roofing system.
7. Review governing regulations and requirements for insurance and certificates if applicable.
8. Review temporary protection requirements for roofing system during and after installation.
9. Review roof observation and repair procedures after roofing installation.

1.5 ACTION SUBMITTALS

- A. Product Data: For each type of product indicated.
 1. Product Data: For roof materials, indicating that roof materials comply with Solar Reflectance Index requirement.
 2. Laboratory Test Reports: For adhesives and sealants used inside the weatherproofing system, indicating compliance with requirements for low-emitting materials.
- B. Shop Drawings: For roofing system. Include plans, elevations, sections, details, and attachments to other Work.
 1. Base flashings and membrane terminations.
 2. Tapered insulation, including slopes.
 3. Insulation fastening patterns for corner, perimeter, and field-of-roof locations.
- C. Samples for Verification: For the following products, in manufacturer's standard sizes:
 1. Sheet roofing, of color specified, including T-shaped side and end lap seam.
 2. Roof insulation, including tapered insulation and slopes.
 3. Walkway pads.
 4. Termination bars.
 5. Six insulation fasteners of each type, length, and finish.

1.6 INFORMATIONAL SUBMITTALS

- A. Qualification Data: For qualified Installer and manufacturer.
- B. Installer Certificates: Signed by roofing system manufacturer certifying that Installer is approved, authorized, or licensed by manufacturer to install roofing system.

- C. Manufacturer Certificates: Signed by roofing manufacturer certifying that roofing system complies with requirements specified in "Performance Requirements" Article.
 - 1. Upon request submit evidence of meeting performance requirements.
 - D. Product Test Reports: Based on evaluation of comprehensive tests performed by manufacturer and witnessed by a qualified testing agency, for components of membrane roofing system.
 - E. Research/Evaluation Reports: For components of membrane roofing system, from the ICC-ES.
 - F. Field quality-control reports.
 - 1. Inspection Reports: Daily reports of roofing inspector, including weather conditions, description of work performed, tests performed, defective work observed, and corrective actions taken to correct defective work.
 - G. Sample Warranties: For manufacturer's special warranties.
- 1.7 CLOSEOUT SUBMITTALS
- A. Maintenance Data: For membrane roofing system to include in maintenance manuals.
- 1.8 QUALITY ASSURANCE
- A. Manufacturer Qualifications: A qualified manufacturer that is UL listed for membrane roofing system identical to that used for this Project.
 - B. Installer Qualifications: A qualified firm that is approved, authorized, or licensed by membrane roofing system manufacturer to install manufacturer's product and that is eligible to receive manufacturer's special warranty.
 - C. Roofing Inspector Qualifications: An RCI Inc.-registered roofing observer (RRO) experienced with roofing-system indicated, or a technical representative of manufacturer not engaged in the sale of products and experienced in the installation and maintenance of the specified roofing system, qualified to perform roofing observation and inspection specified in Field Quality Control Article, to determine Installer's compliance with the requirements of this Project, and approved by the manufacturer to issue warranty certification.
 - 1. Manufacturer's technical representative shall be an authorized full-time technical employee of the manufacturer.
 - 2. Roofing inspector shall be on site for a minimum of 3 full-time days to perform roof tests and inspections and to prepare start up, interim, and final reports.

1.9 DELIVERY, STORAGE, AND HANDLING

- A. Deliver roofing materials to Project site in original containers with seals unbroken and labeled with manufacturer's name, product brand name and type, date of manufacture, and directions for storing and mixing with other components.
- B. Store liquid materials in their original undamaged containers in a clean, dry, protected location and within the temperature range required by roofing system manufacturer. Protect stored liquid material from direct sunlight.
 - 1. Discard and legally dispose of liquid material that cannot be applied within its stated shelf life.
- C. Protect roof insulation materials from physical damage and from deterioration by sunlight, moisture, soiling, and other sources. Store in a dry location. Comply with insulation manufacturer's written instructions for handling, storing, and protecting during installation.
- D. Handle and store roofing materials and place equipment in a manner to avoid permanent deflection of deck.

1.10 FIELD CONDITIONS

- A. Weather Limitations: Proceed with installation only when existing and forecasted weather conditions permit roofing system to be installed according to manufacturer's written instructions and warranty requirements.

1.11 WARRANTY

- A. Special Warranty: Manufacturer's standard form, without monetary limitation, in which manufacturer agrees to repair or replace components of membrane roofing system that fail in materials or workmanship within specified warranty period. Failure includes roof leaks.
 - 1. Special warranty includes membrane roofing, base flashings, roof insulation, fasteners, cover boards, substrate board, walkway products, and other components of membrane roofing system.
 - 2. Warranty wind speed coverage shall be peak gusts of 72 miles per hour, as measured at 10 meters above ground level.
 - 3. Warranty Period: 20 years from date of Substantial Completion.

PART 2 - PRODUCTS

2.1 MANUFACTURERS

- A. Manufacturers: Subject to compliance with requirements, provide products by one of the following:
1. Carlisle SynTec Incorporated.
 2. GenFlex Roofing Systems.
 3. Johns Manville.
 4. Mule-Hide Products Co., Inc.;
 5. Versico Roofing Systems.
- B. Source Limitations: Obtain components for roofing system from or approved by roofing system manufacturer.

2.2 PERFORMANCE REQUIREMENTS

- A. General Performance: Installed membrane roofing and base flashings shall withstand specified uplift pressures, thermally induced movement, and exposure to weather without failure due to defective manufacture, fabrication, installation, or other defects in construction. Membrane roofing and base flashings shall remain watertight.
1. Accelerated Weathering: Roofing system shall withstand 2000 hours of exposure when tested according to ASTM G 152, ASTM G 154, or ASTM G 155.
 2. Impact Resistance: Roofing system shall resist impact damage when tested according to ASTM D 3746 or ASTM D 4272.
- B. Material Compatibility: Provide roofing materials that are compatible with one another under conditions of service and application required, as demonstrated by membrane roofing manufacturer based on testing and field experience.
- C. Roofing System Design: Provide membrane roofing system that is identical to systems that have been successfully tested by a qualified testing and inspecting agency to resist uplift pressure calculated according to ASCE/SEI 7.
1. Corner Uplift Pressure: 87.9 lbf/sq. ft.
 2. Perimeter Uplift Pressure: 58.5 lbf/sq. ft.
 3. Field-of-Roof Uplift Pressure: 34.8 lbf/sq. ft.
 4. Depth of Perimeter and Corner Zones: 5.3 feet.
- D. Roof Edge Design: Comply with requirements of ANSI/SPRI ES-1.
- E. Solar Reflectance Index: Not less than 78 when calculated according to ASTM E 1980, based on testing identical products by a qualified testing agency.
- F. Energy Performance: Provide roofing system that is listed on the DOE's ENERGY STAR "Roof Products Qualified Product List" for low-slope roof products.

- G. Exterior Fire-Test Exposure: ASTM E 108, Class A or Class B; for application and roof slopes indicated, as determined by testing identical membrane roofing materials by a qualified testing agency. Materials shall be identified with appropriate markings of applicable testing agency.

2.3 EPDM MEMBRANE ROOFING

- A. EPDM: ASTM D 4637, Type I, nonreinforced uniform, flexible sheet.
 - 1. Thickness: 60 mils, nominal.
 - 2. Exposed Face Color: Black.

2.4 AUXILIARY MEMBRANE ROOFING MATERIALS

- A. General: Auxiliary membrane roofing materials recommended by roofing system manufacturer for intended use and compatible with membrane roofing.
 - 1. Liquid-type auxiliary materials shall comply with VOC limits of authorities having jurisdiction.
 - 2. Adhesives and sealants that are not on the exterior side of weather barrier shall comply with the testing and product requirements of the California Department of Health Services' "Standard Practice for the Testing of Volatile Organic Emissions from Various Sources Using Small-Scale Environmental Chambers."
- B. Sheet Flashing: 60-mil- thick EPDM, partially cured or cured, according to application.
- C. Prefabricated Pipe Flashings: As recommended by roof membrane manufacturer.
- D. Bonding Adhesive: Manufacturer's standard.
- E. Seaming Material: Manufacturer's standard synthetic-rubber polymer primer and 3-inch-wide minimum, butyl splice tape with release film.
- F. Lap Sealant: Manufacturer's standard single-component sealant, color to match roofing membrane.
- G. Water Cutoff Mastic: Manufacturer's standard butyl mastic sealant.
- H. Metal Termination Bars: Manufacturer's standard predrilled stainless-steel or aluminum bars, approximately 1 by 1/8 inch thick; with anchors.
- I. Miscellaneous Accessories: Provide pourable sealers, preformed cone and vent sheet flashings, preformed inside and outside corner sheet flashings, reinforced EPDM securement strips, T-joint covers, in-seam sealants, termination reglets, cover strips, and other accessories.
 - 1. Provide white flashing accessories for white EPDM membrane roofing.

2.5 SUBSTRATE BOARD

- A. Substrate Board: ASTM C 1177, glass-mat, water-resistant gypsum board.
 - 1. Basis-of-Design Product: Subject to compliance with requirements, provide Georgia-Pacific Gypsum LLC;; Dens Deck Prime, or equal.
 - 2. Thickness: 1/2 inch.
 - 3. Surface Finish: Factory primed.
- B. Fasteners: Factory-coated steel fasteners and metal or plastic plates complying with corrosion-resistance provisions in FM Approvals 4470, designed for fastening substrate panel to roof deck.

2.6 VAPOR RETARDER/TEMPORARY ROOF

- A. Self-Adhering-Sheet Vapor Retarder: ASTM D1970/D1970M, polyethylene film laminated to layer of rubberized asphalt adhesive, minimum 40-mil- total thickness; maximum permeance rating of 0.1 perm; cold applied, with slip-resisting surface and release paper backing. Provide primer when recommended by vapor retarder manufacturer.

2.7 ROOF INSULATION

- A. General: Preformed roof insulation boards manufactured or approved by EPDM membrane roofing manufacturer, selected from manufacturer's standard sizes suitable for application, of thicknesses indicated.
- B. Polyisocyanurate Board Insulation: ASTM C 1289, Type II, Class 1, glass-fiber mat facer on both major surfaces.
 - 1. Compressive Strength:
 - a. Roof Insulation Below Cover Board: 20 psi
 - b. Roof Insulation with No Cover Board: Provide Grade 3 insulation, 25 psi.
- C. Tapered Insulation: Provide factory-tapered insulation boards.
 - 1. Material: Match roof insulation.
 - 2. Minimum Thickness: 1/4 inch.
 - 3. Slope:
 - a. Roof Field: 1/4 inch per foot unless otherwise indicated on Drawings.
 - b. Saddles and Crickets: 1/2 inch per foot unless otherwise indicated on Drawings.
- D. Provide preformed saddles, crickets, tapered edge strips, and other insulation shapes where indicated for sloping to drain. Fabricate to slopes indicated.

2.8 INSULATION ACCESSORIES

- A. General: Furnish roof insulation accessories recommended by insulation manufacturer for intended use and compatible with membrane roofing.
- B. Fasteners: Factory-coated steel fasteners and metal or plastic plates complying with corrosion-resistance provisions in FM Approvals 4470, designed for fastening roof insulation to substrate, and acceptable to roofing system manufacturer.
- C. Insulation Adhesive: Insulation manufacturer's recommended adhesive formulated to attach roof insulation to substrate or to another insulation layer as follows:
 - 1. Bead-applied, low-rise, one-component or multicomponent urethane adhesive.
- D. Cover Board: Glass-mat, water-resistant gypsum substrate, ASTM C 1177, 1/4 inch thick, factory primed.
 - 1. Products: Subject to compliance with requirements, available products that may be incorporated into the Work include, but are not limited to, the following:
 - a. Georgia-Pacific Corporation; DensDeck Prime.
 - b. USG; Securock Glass-Mat Roof Board.

PART 3 - EXECUTION

3.1 EXAMINATION

- A. Examine substrates, areas, and conditions, with Installer present, for compliance with the following requirements and other conditions affecting performance of roofing system:
 - 1. Verify that roof openings and penetrations are in place and curbs are set and braced and that roof drain bodies are securely clamped in place.
 - 2. Verify that wood blocking, curbs, and nailers are securely anchored to roof deck at penetrations and terminations and that nailers match thicknesses of insulation.
 - 3. Verify that surface plane flatness and fastening of steel roof deck complies with requirements in Division 05 Section "Steel Deck."
- B. Proceed with installation only after unsatisfactory conditions have been corrected.

3.2 PREPARATION

- A. Clean substrate of dust, debris, moisture, and other substances detrimental to roofing installation according to roofing system manufacturer's written instructions. Remove sharp projections.
- B. Prevent materials from entering and clogging roof drains and conductors and from spilling or migrating onto surfaces of other construction. Remove roof-drain plugs when no work is taking place or when rain is forecast.

- C. Complete terminations and base flashings and provide temporary seals to prevent water from entering completed sections of roofing system at the end of the workday or when rain is forecast. Remove and discard temporary seals before beginning work on adjoining roofing.

3.3 SUBSTRATE BOARD

- A. Install substrate board with long joints in continuous straight lines, with end joints staggered not less than 24 inches in adjacent rows.
 - 1. At steel roof decks, install substrate board at right angle to flutes of deck.
 - a. Locate end joints over crests of steel roof deck.
 - 2. Tightly butt substrate boards together.
 - 3. Cut substrate board to fit tight around penetrations and projections, and to fit tight to intersecting sloping roof decks.
 - 4. Fasten substrate board to top flanges of steel deck to resist uplift pressure at corners, perimeter, and field of roof according to roofing system manufacturers' written instructions.

3.4 VAPOR-RETARDER/TEMPORARY ROOF INSTALLATION

- A. Self-Adhering-Sheet Vapor Retarder: Prime substrate if required by manufacturer. Install self-adhering-sheet vapor retarder over area to receive vapor retarder, side and end lapping each sheet a minimum of 3-1/2 and 6 inches, respectively.
 - 1. Extend vertically up parapet walls and projections to a minimum height equal to height of insulation and cover board.
 - 2. Seal laps by rolling.
- B. Completely seal vapor retarder at terminations, obstructions, and penetrations to prevent air movement into membrane roofing system.

3.5 INSULATION INSTALLATION

- A. Coordinate installing membrane roofing system components so insulation is not exposed to precipitation or left exposed at the end of the workday.
- B. Comply with membrane roofing system manufacturer's written instructions for installing roof insulation.
- C. Install tapered insulation under area of roofing to conform to slopes indicated.
- D. Install one or more layers of insulation under area of roofing to achieve required thickness. Where overall insulation thickness is 2.7 inches or greater, install 2 or more layers with joints of each succeeding layer staggered from joints of previous layer a minimum of 18 inches in each direction.

- E. Trim surface of insulation where necessary at roof drains so completed surface is flush and does not restrict flow of water.
- F. Install insulation with long joints of insulation in a continuous straight line with end joints staggered between rows, abutting edges and ends between boards. Fill gaps exceeding 1/4 inch with insulation.
 - 1. Cut and fit insulation within 1/4 inch of nailers, projections, and penetrations.
- G. Adhered Insulation Over Vapor Retarder/Temporary Roof: Adhere each layer of insulation to substrate in ribbons of bead-applied insulation adhesive, firmly pressing and maintaining insulation in place.
 - 1. Install bead foam adhesive parallel to insulation-board side edges in wet widths of 3/4 inch at 4 inches o.c.; 14 rows per 4'-0" width of insulation.
 - 2. Embed insulation into bead foam adhesive, with joints staggered minimum 18 inches from joints of first layer. Step into place and position; roll insulation with 90-lbf water roller to achieve positive contact and adhesion between adhesive and insulation board. Verify that no creeping occurs.
 - 3. Weight insulation down with 5-gal adhesive pails until bead foam adhesive has set; one in center and one on each corner, so that no cupping or lack of adhesion occurs. Insulation that 'bounces' or depresses under foot pressure is unacceptable.
- H. Install cover boards over insulation with long joints in continuous straight lines with end joints staggered between rows. Offset joints of insulation below a minimum of 18 inches in each direction. Set cover boards in ribbons of bead-applied insulation adhesive, firmly pressing and maintaining cover boards in place.
 - 1. Install bead foam adhesive parallel to edge of insulation board side edge in wet widths of 3/4 inch at 4 inches o.c.; 14 per 4'-0" width of insulation.
 - 2. Embed coverboard with full contact into bead foam adhesive. Step into place and position; roll with 90-lbf water roller. Verify that no creeping occurs. Weight with 5-gallon adhesive pails; one in the center and one on each corner to achieve positive contact and adhesion.

3.6 ADHERED MEMBRANE ROOFING INSTALLATION

- A. Adhere membrane roofing over area to receive roofing according to membrane roofing system manufacturer's written instructions. Unroll roofing membrane and allow to relax before installing.
 - 1. Do not crease field membrane.
- B. Start installation of membrane roofing in presence of membrane roofing system manufacturer's technical personnel.
- C. Accurately align roofing membrane and maintain uniform side and end laps of minimum dimensions required by manufacturer. Stagger end laps.

- D. Bonding Adhesive: Apply to substrate and underside of roofing membrane at rate required by manufacturer and allow to partially dry before installing roofing membrane. Do not apply bonding adhesive to splice area of roofing membrane.
 - 1. Roll membrane with large water filled roller to achieve 100-percent bonding.
- E. In addition to adhering, mechanically fasten membrane roofing securely at terminations, penetrations, and perimeters.
- F. Apply membrane roofing with side laps shingled with slope of roof deck where possible.
- G. Tape Seam Installation: Clean and prime both faces of splice areas, apply splice tape, and firmly roll side and end laps of overlapping membrane roofing according to manufacturer's written instructions to ensure a watertight seam installation. Apply lap sealant and seal exposed edges of membrane roofing terminations.
- H. Leave seams uncovered until inspected by roofing system manufacturer.
- I. Repair tears, voids, and lapped seams in roofing that does not meet requirements.
- J. Spread sealant or mastic bed over deck drain flange at deck drains and securely seal roofing membrane in place with clamping ring.
- K. Install membrane roofing and auxiliary materials to tie in to existing membrane roofing to maintain weather-tightness of transition and to not void warranty for existing membrane roofing system.

3.7 BASE FLASHING INSTALLATION

- A. Install sheet flashings and preformed flashing accessories and adhere to substrates according to membrane roofing system manufacturer's written instructions.
- B. Apply bonding adhesive to substrate and underside of sheet flashing at required rate and allow to partially dry. Do not apply bonding adhesive to seam area of flashing.
- C. Flash penetrations and field-formed inside and outside corners with cured or uncured sheet flashing.
- D. Clean splice areas, apply splicing cement, and firmly roll side and end laps of overlapping sheets to ensure a watertight seam installation. Apply lap sealant and seal exposed edges of sheet flashing terminations.
- E. Terminate and seal top of sheet flashings and mechanically anchor to substrate through termination bars.

3.8 FIELD QUALITY CONTROL

- A. Final Roof Inspection: Arrange for roofing system manufacturer's technical personnel to inspect roofing installation on completion and submit report to Architect.

- B. Repair or remove and replace components of membrane roofing system where test results or inspections indicate that they do not comply with specified requirements.
- C. Additional inspections, at Contractor's expense, will be performed to determine compliance of replaced or additional work with specified requirements.

3.9 PROTECTING AND CLEANING

- A. Protect membrane roofing system from damage and wear during remainder of construction period. When remaining construction will not affect or endanger roofing, inspect roofing for deterioration and damage, describing its nature and extent in a written report, with copies to Architect and Owner.
 - 1. Provide 1/2-inch thick plywood walk boards on 1-inch thick expanded polystyrene in areas of heavy traffic and take other measures necessary to prevent damage to roofing system.
- B. Correct deficiencies in or remove membrane roofing system that does not comply with requirements, repair substrates and repair or reinstall membrane roofing system to a condition free of damage and deterioration at time of Substantial Completion and according to warranty requirements.
- C. Clean overspray and spillage from adjacent construction using cleaning agents and procedures recommended by manufacturer of affected construction.

END OF SECTION 075323

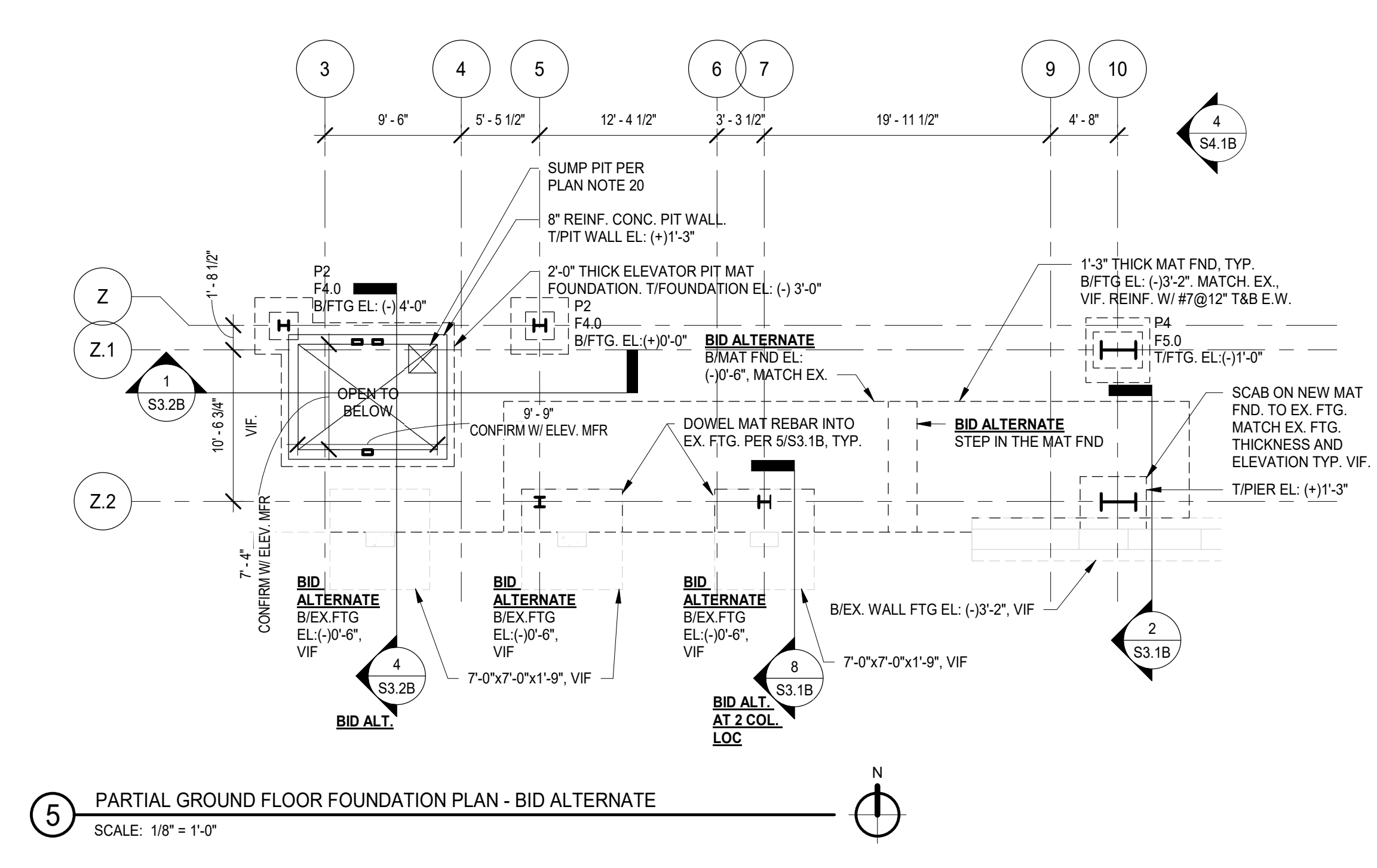
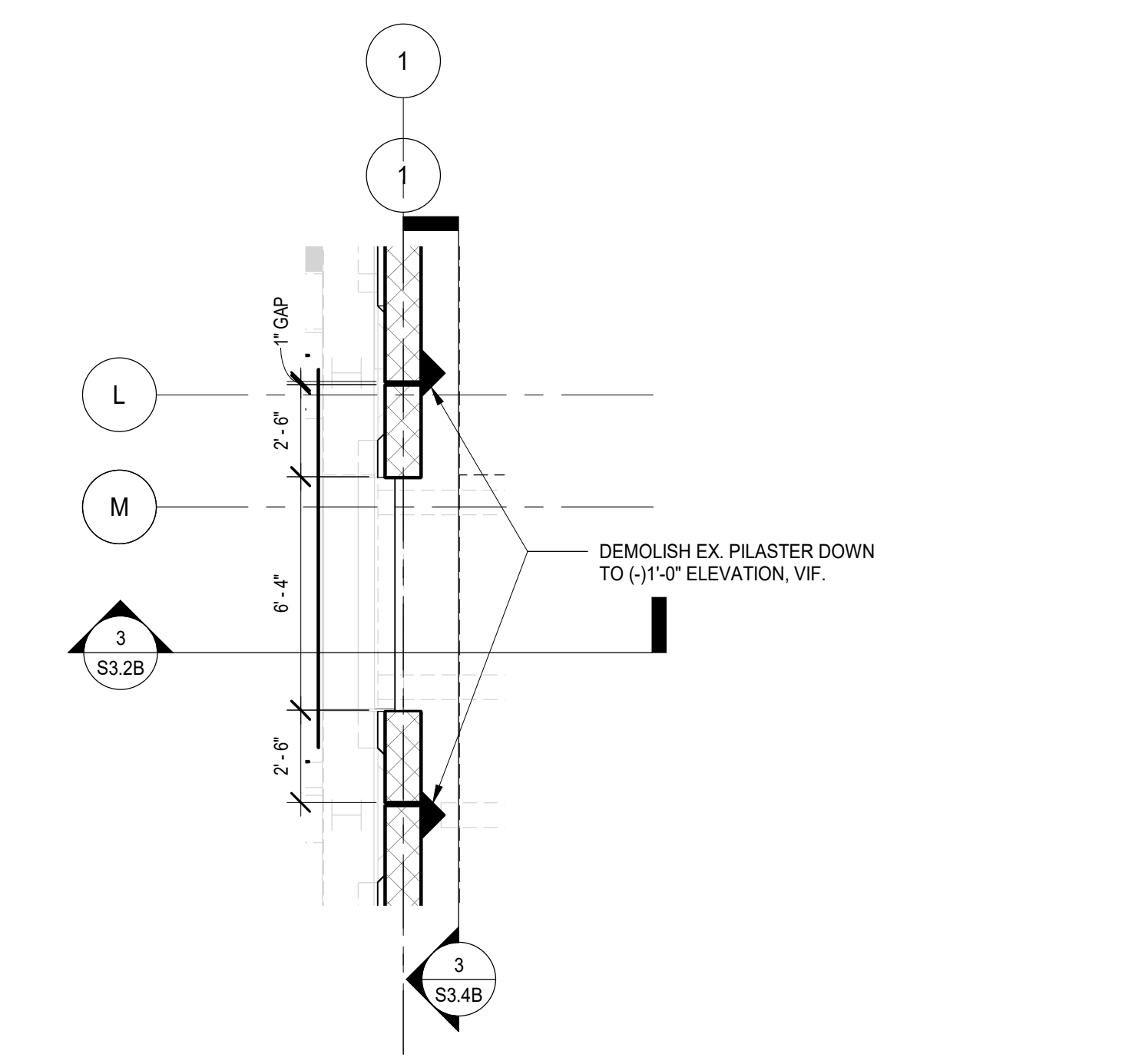
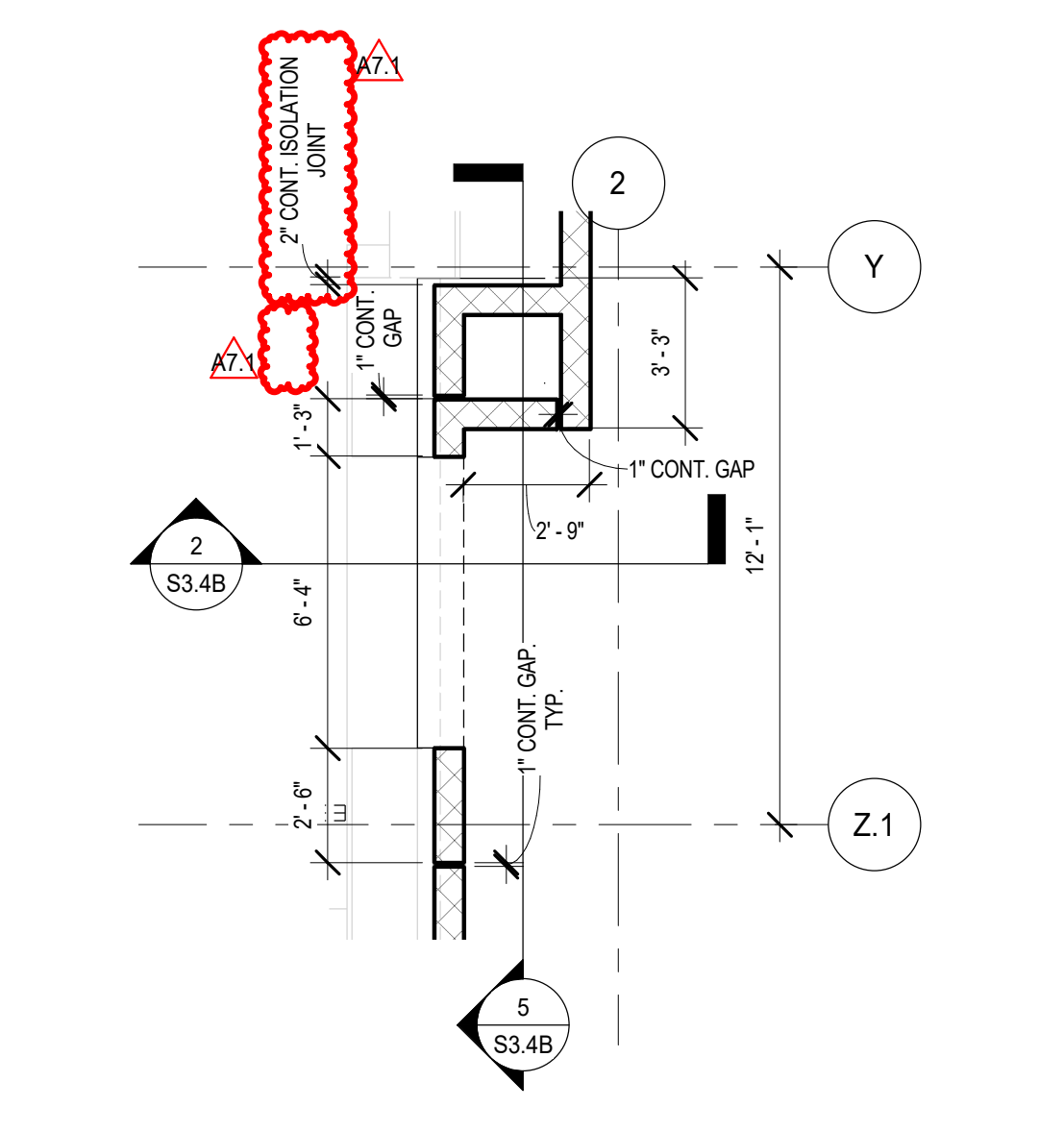
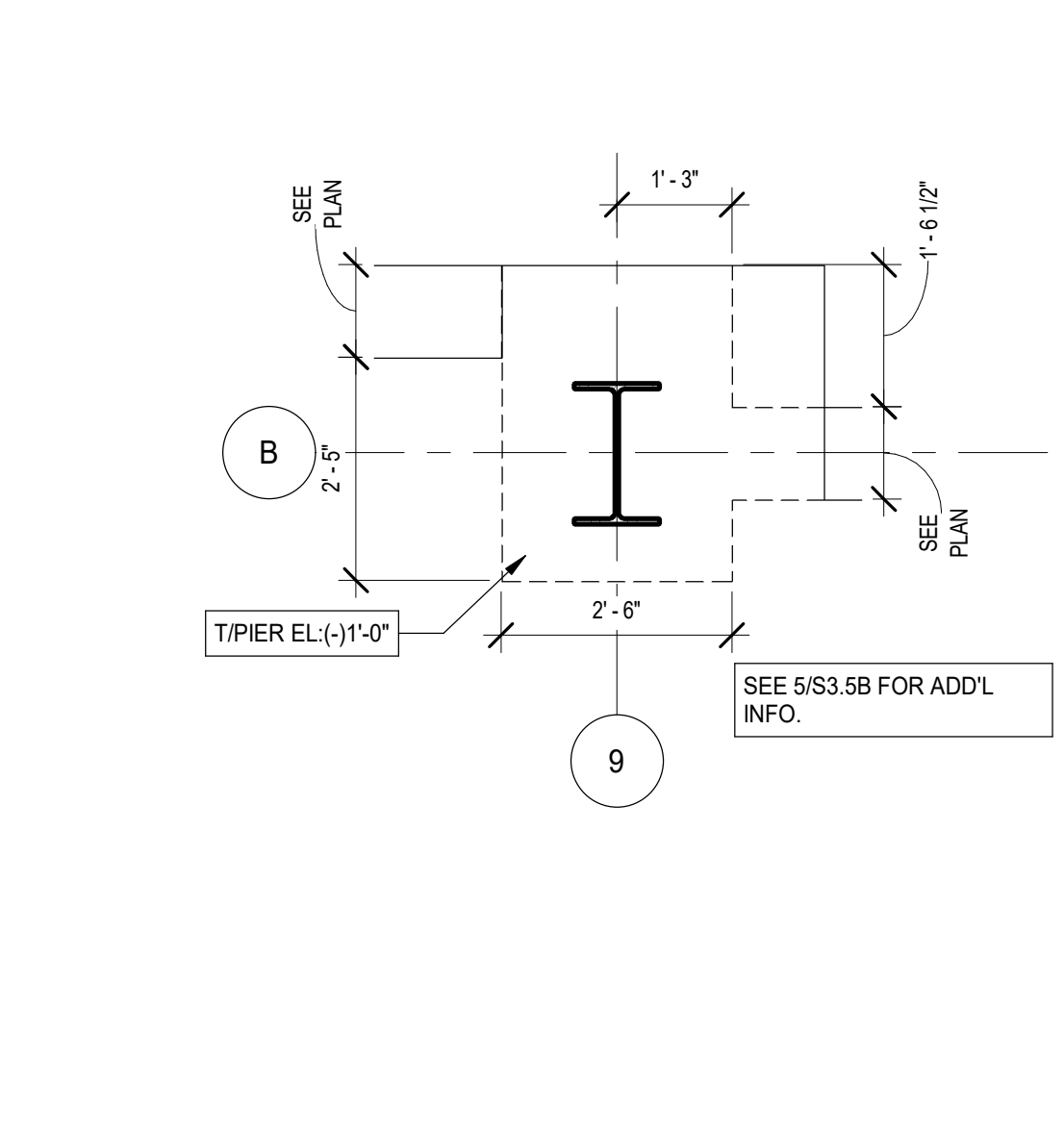
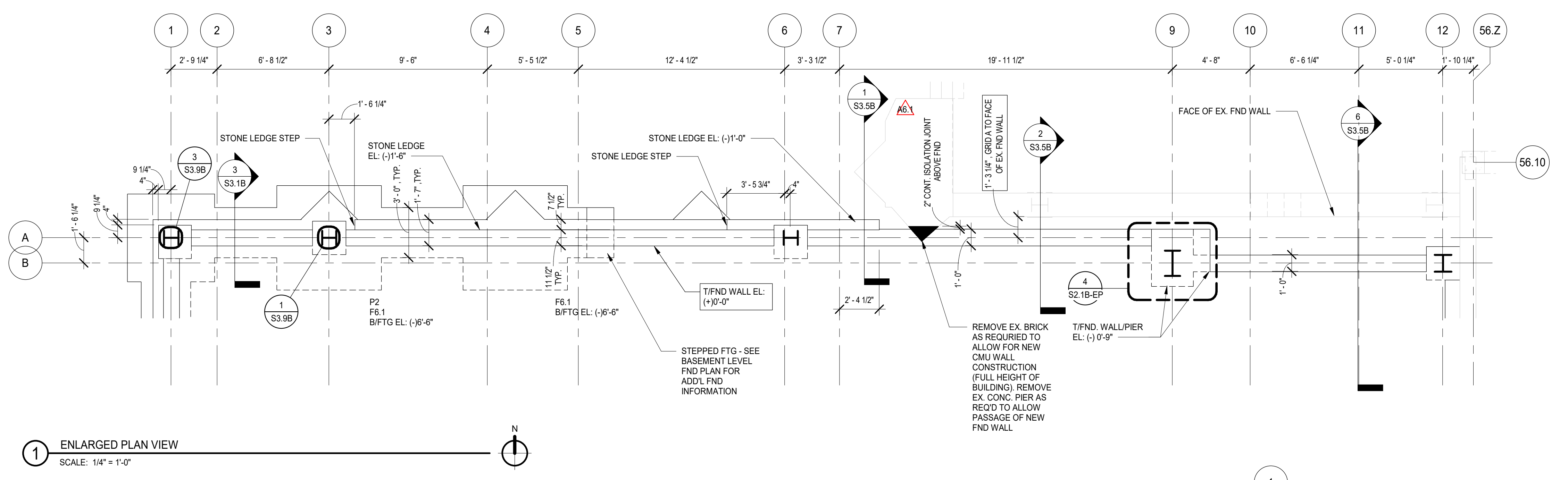
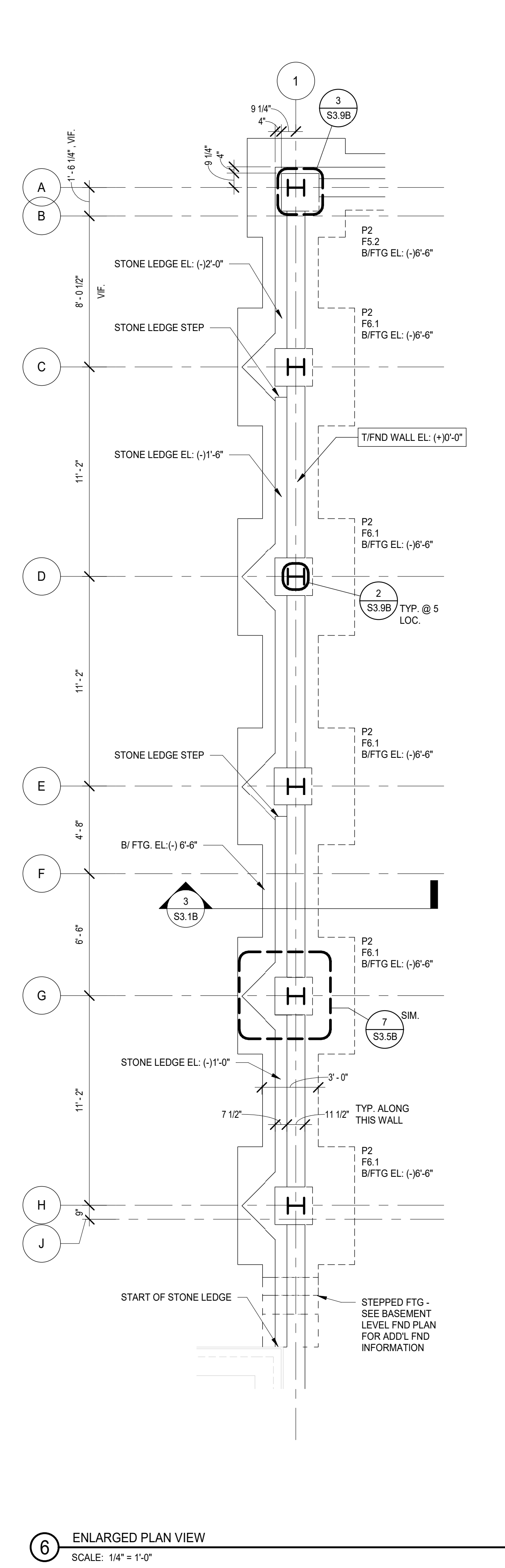
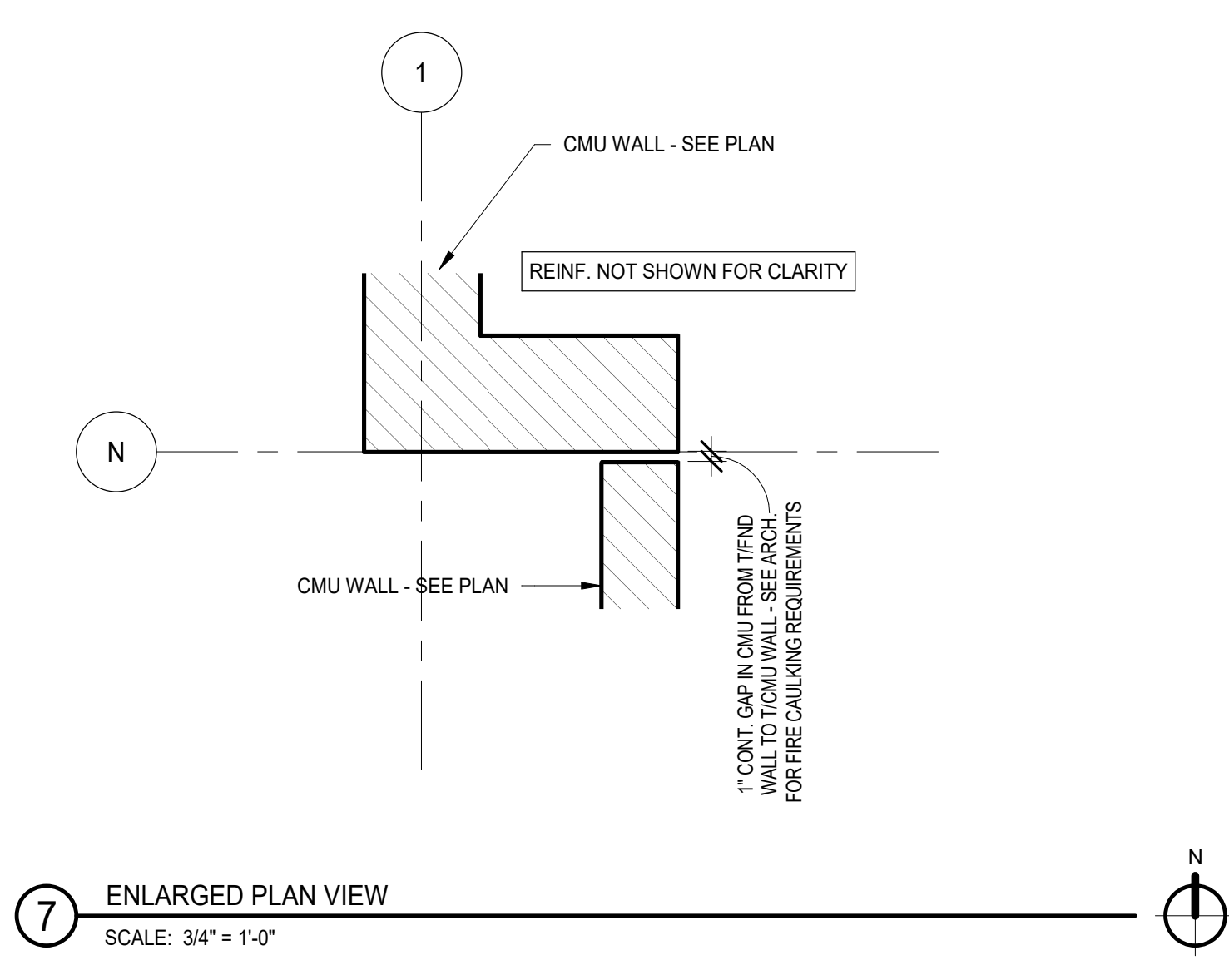
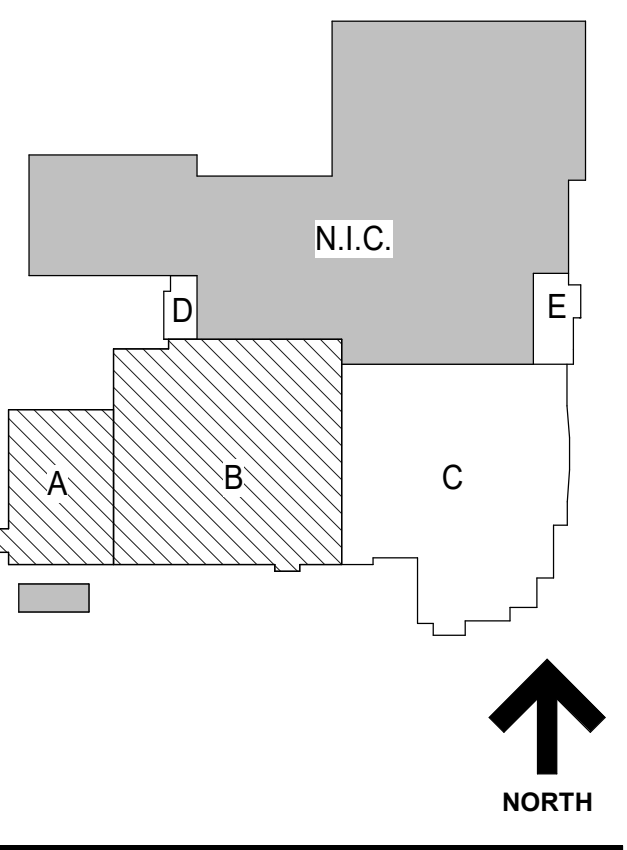

NOT FOR CONSTRUCTION

6/25/2019 9:44:03 AM
 C:\Users\akumar\Documents\11-5274-42_DCN_Spec_2019_Central_Aulavm.rvt
 Wight & Co. © Copyright 2019 All rights reserved. No part of these documents may be reproduced, stored, or transmitted in any form or by any means, electronic, photocopying, recording or otherwise, without the prior written consent of Wight & Co.

A7.1	ISSUED FOR ADDENDUM A7.1 - BID GROUP 7	06.26.2019
A6.1	ISSUED FOR ADDENDUM A6.1 - BID GROUP 6	05.31.2019
	ISSUED FOR ADDENDUM A6.1 - BID GROUP 6	05.31.2019
	ISSUED FOR ADDENDUM A6.1 - BID GROUP 6	05.10.2019
	ISSUED FOR 75% CD - PHASE B	05.10.2019
REV	ISSUE	DATE

MFP IMPLEMENTATION - NORTH

4436 MAIN STREET
DOWNERS GROVE, IL 60515

ENLARGED PLANS - PHASE B

Project Number:
5274-42
Drawn By:
I.K.
Sheet:

S2.1B-EP



COMMUNITY HIGH SCHOOL DISTRICT 99



Wight & Company
wightco.com
2500 North Frontage Road
Darien, IL 60561
P 630.969.7000
F 630.969.7979

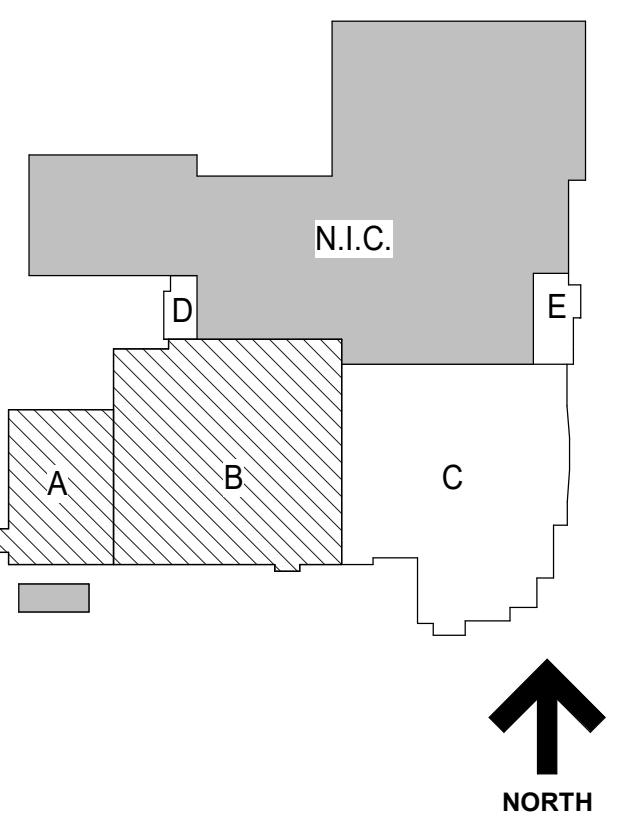

NOT FOR CONSTRUCTION

REV	ISSUE	DATE
A7.1	ISSUED FOR ADDENDUM A7.1 - BID GROUP 7	06.26.2019
	ISSUED FOR BID-BID GROUP 7	06.07.2019
A6.1	ISSUED FOR ADDENDUM A6.1 - BID GROUP 6	05.31.2019
	ISSUED FOR BID-BID GROUP 6	05.10.2019
	ISSUED FOR 75% CD - PHASE B	05.10.2019
	ISSUED FOR 50% CD - PHASE B	04.12.2019
	ISSUED FOR DESIGN DEVELOPMENT - PHASE B	03.11.2019

MFP IMPLEMENTATION - NORTH

4436 MAIN STREET
DOWNERS GROVE, IL 60515

SECOND AND THIRD FLOOR FRAMING - PHASE B

Project Number: 5274-42
Drawn By: J.G.
Sheet: S2.2B

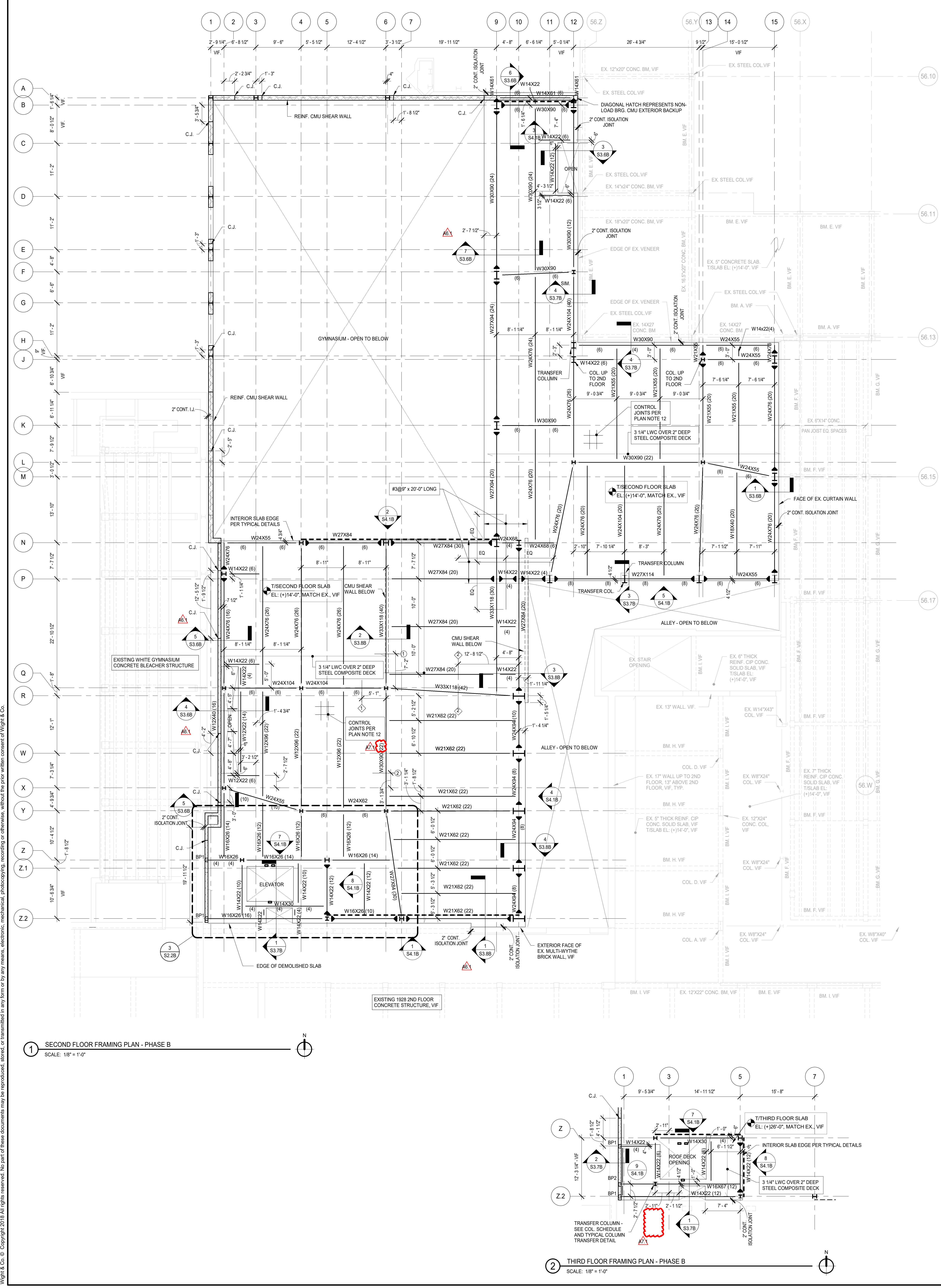

ELEVATED FLOOR AND ROOF LEVEL PLAN NOTES

- SEE S0 SERIES DRAWINGS FOR GENERAL NOTES, ABBREVIATIONS, SYMBOLS AND Lintel SCHEDULES, AND STATEMENT OF SPECIAL INSPECTIONS.
- SEE S1 SERIES DRAWINGS FOR TYPICAL SECTIONS AND DETAILS.
- SEE S3 SERIES DRAWINGS FOR NON-TYPICAL SECTIONS AND DETAILS.
- SEE S4 SERIES DRAWINGS FOR SCHEDULES, ELEVATIONS AND DETAILS.
- CENTERLINE OF COLUMN IS ON GRIDLINE. TYPICAL UNLESS NOTED OTHERWISE.
- SEE PLANS FOR COLUMN ORIENTATION AND COLUMN CENTERLINE TO GRIDLINE DIMENSIONS FOR OFFSET COLUMNS.
- SEE PLANS FOR TOP OF ROUGH SLAB ELEVATION.
- (H) AS INDICATED ON PLAN INDICATES HIGHER BEAM OF FRAMING MEMBERS IN SAME VERTICAL PLANE.
- (L) AS INDICATED ON PLAN INDICATES LOWER BEAM OF FRAMING MEMBERS IN SAME VERTICAL PLANE.
- SEE ARCHITECTURAL DRAWINGS FOR CURBS NOT INDICATED (SIZE AND LOCATION). SEE TYPICAL SECTIONS AND DETAILS FOR CURB REINFORCEMENT.
- FLOOR DECK SHALL BE 3" DEEP CONTROL JOINTS AT AREAS OF EXPOSED "SEALED CONCRETE" SLABS. LOCATE JOINTS AT COLUMN CENTERLINES AND 12 FEET CTS MAX AT REMAINDER EQUIVALENT.
- SAW CUT 1/4" WIDE X 1/2" DEEP CONTROL JOINTS AT AREAS OF EXPOSED "SEALED CONCRETE" SLABS. LOCATE JOINTS AT COLUMN CENTERLINES AND 12 FEET CTS MAX AT REMAINDER EQUIVALENT.
- SEE PLAN FOR TOP OF SLAB ELEVATION, TYPICAL UNLESS NOTED OTHERWISE.
- VERIFY ELEVATOR MACHINE BEAM SIZES AND LOCATIONS WITH ELEVATOR SUPPLIER.
- SEE PLAN FOR BOTTOM OF STEEL ROOF DECK ELEVATIONS, TYPICAL UNLESS NOTED OTHERWISE.
- PROVIDE L4x4x3/8 STEEL ANGLE OR RENT PLATE AT ROOF PERIMETER AND AT INTERIOR OPENINGS IN ACCORDANCE WITH TYPICAL DETAILS.
- SEE S2.3B FOR SPECIAL DESIGN JOIST SCHEMATIC LOADINGS.
- SUSPEND PIPE HANGERS AND OTHER MECHANICAL EQUIPMENT FROM DESIGNATED OR APPROVED STEEL JOISTS. LOCATE CONCENTRATED LOADS AT JOIST PANEL POINTS ONLY OR REINFORCE STEEL JOISTS IN ACCORDANCE WITH TYPICAL SECTIONS AND DETAILS.
- PLACE SUPPORTS FOR ROOF TOP EQUIPMENT LOADS ON DESIGNATED OR APPROVED STEEL JOISTS. LOCATE CONCENTRATED LOADS AT JOIST PANEL POINTS ONLY OR REINFORCE STEEL JOISTS IN ACCORDANCE WITH TYPICAL SECTIONS AND DETAILS.
- AT THE NEW ADDITION, ALL ROOFS WITH THE STEEL ROOF DECK ARE DESIGNED TO SUPPORT A MAXIMUM ALLOWED SUPERIMPOSED DEAD LOAD FROM THE PHOTOVOLTAIC BALLASTED SYSTEM OF 8 PSF PLUS THE ADDITIONAL DOWNWARD WIND PRESSURE FROM THE PHOTOVOLTAIC BALLASTED SYSTEM OF 13 PSF. SYSTEMS OTHER THAN THE PHOTOVOLTAIC BALLASTED SYSTEM ARE NOT PERMITTED.
- 2ND FLOOR COMPOSITE DECK SLAB SHALL RECEIVE TROWEL FINISH PER SPECIFICATION SECTION 03300, SECTION 3.3.C. COORDINATE TROWELING AND FLOATING PROCEDURE WITH THE MACRO-SYNTHETIC FIBER SUPPLIER/MANUFACTURER.
- SEE STEEL DECK NOTES ON S0.1B FOR STEEL DECK ATTACHMENT INFORMATION TO THE SUPPORT STEEL.
- SEE THE GROUND FLOOR FOUNDATION PLAN FOR CMU WALL CONTROL JOINT LOCATIONS.
- MAXIMUM LIVE LOAD DEFLECTION FOR ROOF LEVEL @ BLDG ENVELOPE & INTERIOR PARTITIONS AS SHOWN ON ARCHITECTURE DRAWINGS = 1"
- THE NEW ADDITION STRUCTURE CONSISTS OF STEEL ROOF DECKS SUPPORTED ON STEEL JOIST, BEAM AND COLUMN FRAMING AND THE 2ND FLOOR COMPOSITE DECK SLABS SUPPORTED ON STEEL BEAM AND COLUMN FRAMING. THE VERTICAL LATERAL RESISTING SYSTEM CONSISTS OF STEEL BRACED FRAMES, STEEL MOMENT FRAMES AND REINFORCED MASONRY SHEAR WALLS. THE STEEL CONTRACTOR SHALL PROVIDE TEMPORARY BRACING TO THE STEEL FRAME UNTIL ALL COMPONENTS OF THE STEEL FRAMING ARE FULLY INSTALLED. THE FLOOR SLABS AND ROOF DECKS ARE FULLY INSTALLED AND THE STEEL FRAME IS PROPERLY CONNECTED TO THE REINFORCED MASONRY SHEAR WALL.
- ALL MEP EQUIPMENT STEEL SUPPORTS SHALL BE COORDINATED WITH THE INSTALLING CONTRACTOR(S). SEE PLANS AND TYPICAL DETAILS FOR STEEL SUPPORT REQUIREMENTS.
- COORDINATE SIZE AND QUANTITY OF ROOF DECK PENETRATIONS WITH MEPP DRAWINGS, TYP. REINFORCE NEW PENETRATIONS IN EXISTING NEW ROOF DECKS PER TYPICAL STRUCTURAL DETAILS.
- DESIGN AND DETAIL ANGLE CONNECTION TO THE TOP OF STEEL COLUMN AND TO THE ROOF JOIST TOP CHORD FOR AN AXIAL FORCE OF 5 KIPS. JOIST SUPPLIER/MANUFACTURER SHALL DESIGN THE STEEL JOIST TOP CHORD FOR THE AFORESAID ANGLE AXIAL FORCE.
- L4x4x3/8 HORIZ. ANGLE TO UNDERSIDE OF ROOF DECK. WELD DECK TO ANGLE, TYP.
- MAXIMUM LIVE LOAD DEFLECTION FOR 2ND FLOOR LEVEL = 1"
- SEE S6.1S8 FOR TYPICAL 2ND FLOOR SLAB REINFORCEMENT DETAIL AT GYMNASIUM EQUIPMENT ANCHORAGE LOCATIONS.
- P = ___ KIPS REPRESENTS HORIZONTAL AXIAL SERVICE LEVEL FORCE IN THE ROOF MEMBER.

EXISTING TYPICAL CONCRETE COLUMN SCHEDULE

COLUMN NOTATION	SIZE
1. COL_A	16"x16"
2. COL_B	12"x16"
3. COL_C	12"x12"
4. COL_D	12"x24"

EXISTING TYPICAL CONCRETE BEAM SCHEDULE

BEAM NOTATION	SIZE
1. BM_A	18"x18"
2. BM_B	14"x30"
3. BM_C	16"x30"
4. BM_D	12"x28"
5. BM_E	12"x20"
6. BM_F	9"x18"
7. BM_G	14"x18"
8. BM_H	12"x24"
9. BM_I	12"x18"

BEAM BEARING PLATE SCHEDULE

TYPE	SIZE	HEADED STUDS	BEAM BEARING LENGTH ON BP	REMARKS
BP1	1/2"x7"x8"	(2)1/2" DIA. x 6" LONG	6"	
BP2	1/2"x7"x11"	(3)1/2" DIA. x 6" LONG	7"	
BP3	1/2"x7"x10"		7"	SOLID GROUT BEAM POCKET

NOTE: UNDER EACH BRG. PLATE, SOLID GROUT CMU WALL 3 CELLS WIDE, DOWN TO THE FOUNDATION

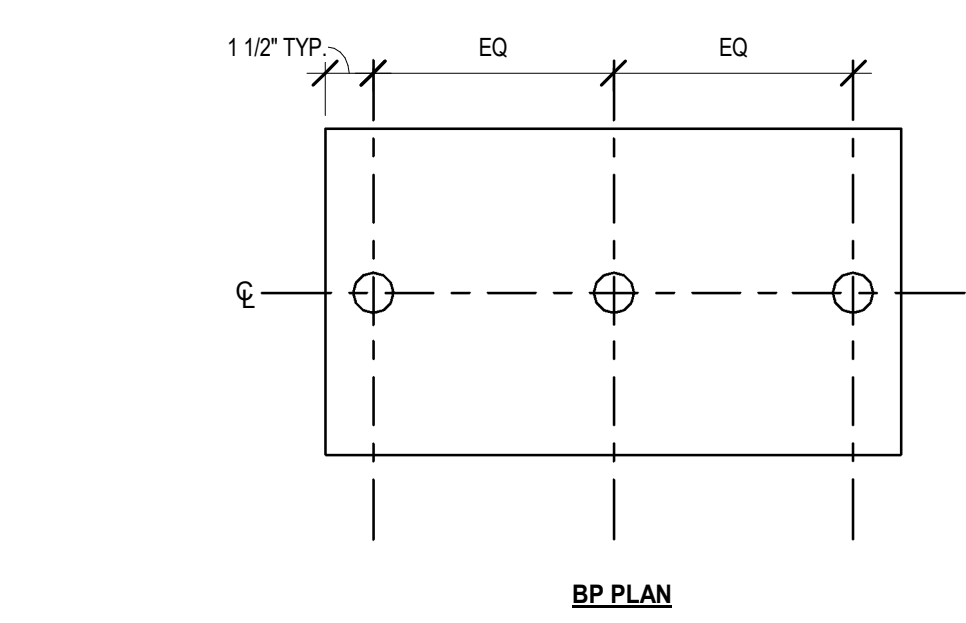

1 SECOND FLOOR FRAMING PLAN - PHASE B
SCALE: 1/8" = 1'-0"

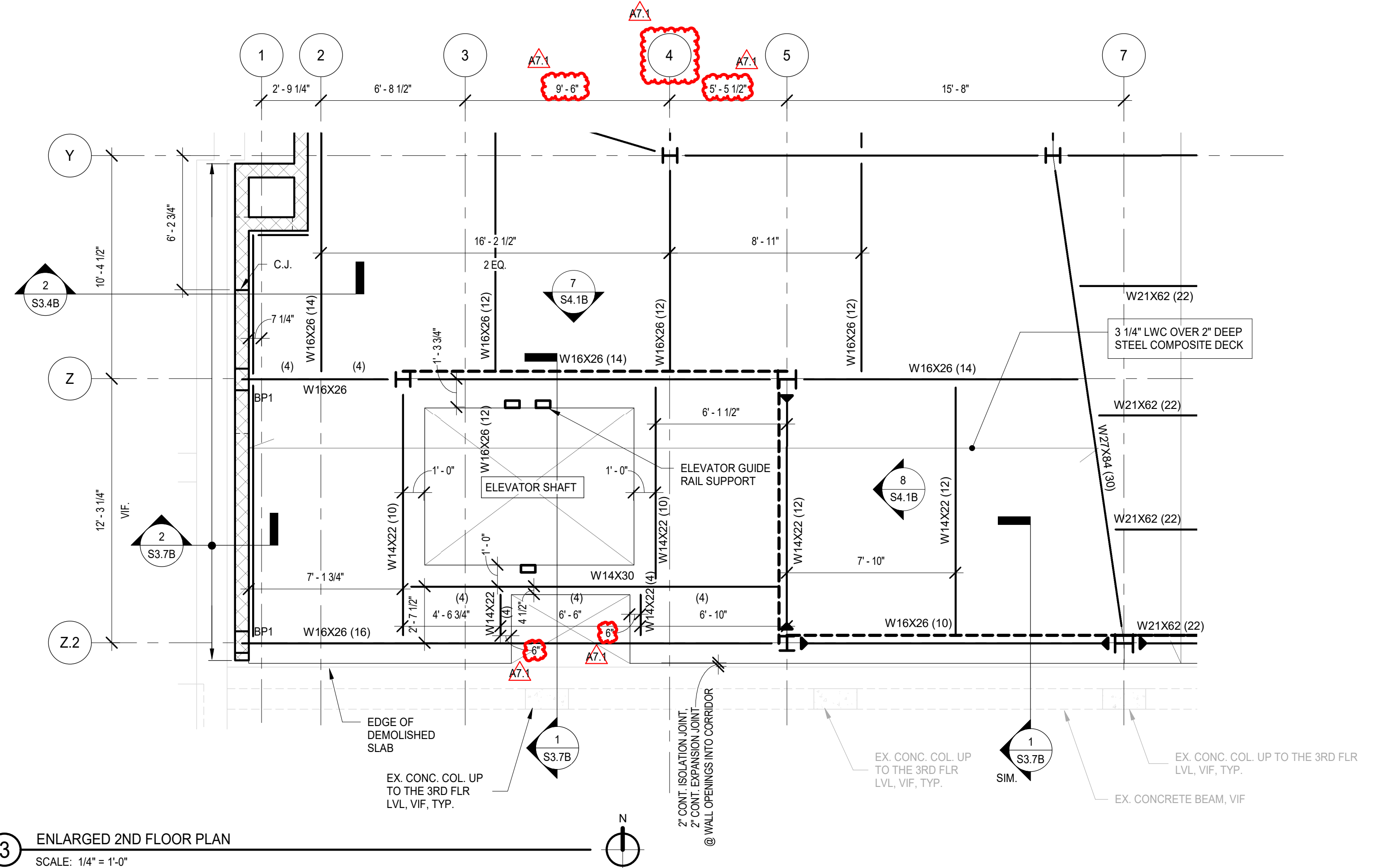
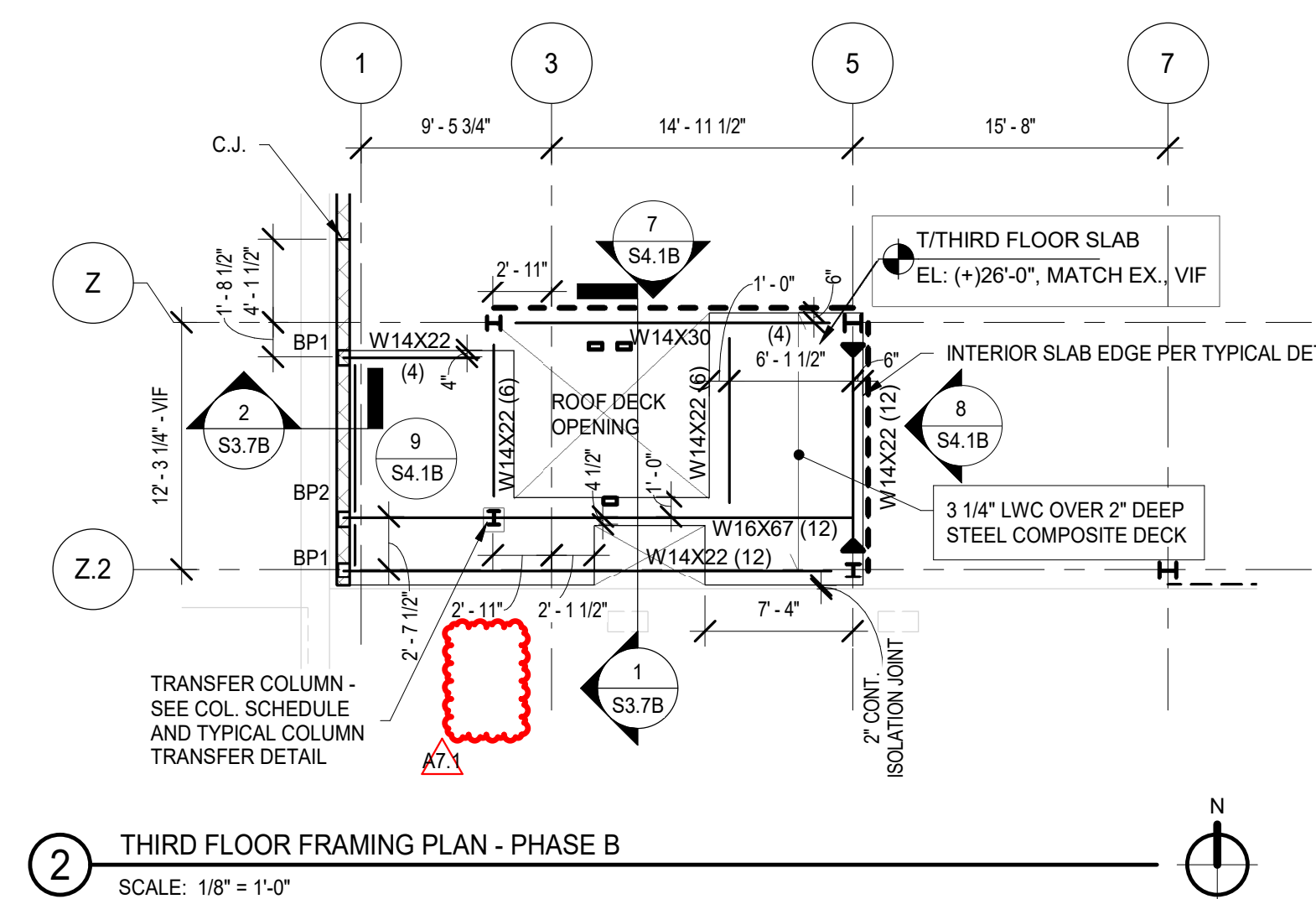

6/25/2019 9:40:09 AM
C:\Users\jacob\Documents\11-2714-2_DGN_Shtc_2019_Central_Aulburn.dwg
Wight & Co. © Copyright 2019 All rights reserved. No part of these documents may be reproduced, stored, transmitted in any form or by any means, electronic, mechanical, photocopying, recording or otherwise, without the prior written consent of Wight & Co.

ELEVATED FLOOR AND ROOF LEVEL PLAN NOTES

- SEE S0 SERIES DRAWINGS FOR GENERAL NOTES, ABBREVIATIONS, SYMBOLS AND LINTEL SCHEDULES, AND STATEMENT OF SPECIAL INSPECTIONS.
- SEE S1 SERIES DRAWINGS FOR TYPICAL SECTIONS AND DETAILS.
- SEE S3 SERIES DRAWINGS FOR NON-TYPICAL SECTIONS AND DETAILS.
- SEE S4 SERIES DRAWINGS FOR SCHEDULES, ELEVATIONS AND DETAILS.
- CENTERLINE OF COLUMN IS ON GRIDLINE. TYPICAL UNLESS NOTED OTHERWISE.
- SEE PLANS FOR COLUMN ORIENTATION AND COLUMN CENTERLINE TO GRIDLINE DIMENSIONS FOR OFFSET COLUMNS.
- SEE PLANS FOR TOP OF ROUGH SLAB ELEVATION.
- (H) AS INDICATED ON PLAN INDICATES HIGHER BEAM OF FRAMING MEMBERS IN SAME VERTICAL PLANE.
- (L) AS INDICATED ON PLAN INDICATES LOWER BEAM OF FRAMING MEMBERS IN SAME VERTICAL PLANE.
- SEE ARCHITECTURAL DRAWINGS FOR CURBS NOT INDICATED (SIZE AND LOCATION). SEE TYPICAL SECTIONS AND DETAILS FOR CURB REINFORCEMENT.
- FLOOR DECK SHALL BE 3 1/4" THICK LIGHTWEIGHT CONCRETE OVER 2" DEEP COMPOSITE STEEL FLOOR DECK. REINFORCE SLABS WITH 4 #5 @ 18" O.C. OF STRU 5040 MACROSYNTHETIC FIBERS OR EQUIVALENT.
- SAW CUT 1/4" WIDE X 1/2" DEEP CONTROL JOINTS AT AREAS OF EXPOSED "SEALED CONCRETE" SLABS. LOCATE JOINTS AT COLUMN CENTERLINES AND 12 FEET CTS MAX AT REMAINDER.
- SEE PLAN FOR TOP OF SLAB ELEVATION, TYPICAL UNLESS NOTED OTHERWISE.
- VERIFY ELEVATOR MACHINE BEAM SIZES AND LOCATIONS WITH ELEVATOR SUPPLIER.
- SEE PLAN FOR BOTTOM OF STEEL ROOF DECK ELEVATIONS, TYPICAL UNLESS NOTED OTHERWISE.
- PROVIDE L4x4x3/8 STEEL ANGLE OR BENT PLATE AT ROOF PERIMETER AND AT INTERIOR OPENINGS IN ACCORDANCE WITH TYPICAL DETAILS.
- SEE S2.3B FOR SPECIAL DESIGN JOIST SCHEMATIC LOADINGS.
- SUSPEND PIPE HANGERS AND OTHER MECHANICAL EQUIPMENT FROM DESIGNATED OR APPROVED STEEL JOISTS. LOCATE CONCENTRATED LOADS AT JOIST PANEL POINTS ONLY OR REINFORCE STEEL JOISTS IN ACCORDANCE WITH TYPICAL SECTIONS AND DETAILS.
- PLACE SUPPORTS FOR ROOF TOP EQUIPMENT LOADS ON DESIGNATED OR APPROVED STEEL JOISTS. LOCATE CONCENTRATED LOADS AT JOIST PANEL POINTS ONLY OR REINFORCE STEEL JOISTS IN ACCORDANCE WITH TYPICAL SECTIONS AND DETAILS.
- SUPPORT ALL MEPPF EQUIPMENT AND PIPING GREATER THAN 2 INCHES IN DIAMETER DIRECTLY FROM THE DESIGNATED STEEL ROOF JOISTS (TOP CHORDS ONLY) AND STEEL WIDE FLANGED BEAM AND GIRDER FRAMING. DO NOT SUPPORT THE AFORESAIDED FROM THE STEEL ROOF DECK DIRECTLY. ITEMS SUCH AS LIGHTWEIGHT CEILING AND LIGHTING MAY BE SUPPORTED DIRECTLY FROM THE STEEL ROOF DECK.
- AT THE NEW ADDITION, ALL ROOFS WITH THE STEEL ROOF DECKS ARE DESIGNED TO SUPPORT A MAXIMUM ALLOWED SUPERIMPOSED DEAD LOAD FROM THE PHOTOVOLTAIC BALLASTED SYSTEM OF 3 PSF PLUS THE ADDITIONAL DOWNWARD WIND PRESSURE FROM THE PHOTOVOLTAIC BALLASTED SYSTEM OF 1.5 PSF. SYSTEMS OTHER THAN THE PHOTOVOLTAIC BALLASTED SYSTEM ARE NOT PERMITTED.
- 2ND FLOOR COMPOSITE DECK SLAB SHALL RECEIVE TROWEL FINISH PER SPECIFICATION SECTION 03300, SECTION 3.0-C. COORDINATE TROWELING AND FLOATING PROCEDURE WITH THE MACROSYNTHETIC FIBER SUPPLIER/MANUFACTURER.
- SEE STEEL DECK NOTES ON S0.1B FOR STEEL DECK ATTACHMENT INFORMATION TO THE SUPPORT STEEL.
- SEE THE GROUND FLOOR FOUNDATION PLAN FOR CMU WALL CONTROL JOINT LOCATIONS.
- MAXIMUM LIVE LOAD DEFLECTION FOR ROOF LEVEL @ BLDG ENVELOPE & INTERIOR PARTITIONS AS SHOWN ON ARCHITECTURE DRAWINGS = 1"
- THE NEW ADDITION STRUCTURE CONSISTS OF STEEL ROOF DECKS SUPPORTED ON STEEL JOIST, BEAM AND COLUMN FRAMING AND THE 2ND FLOOR COMPOSITE DECK SLABS SUPPORTED ON STEEL BEAM AND COLUMN FRAMING. THE VERTICAL LATERAL RESISTING SYSTEM CONSISTS OF STEEL BRACED FRAMES, STEEL MOMENT FRAMES AND REINFORCED MASONRY SHEAR WALLS. THE STEEL CONTRACTOR SHALL PROVIDE TEMPORARY BRACING TO THE STEEL FRAME UNTIL ALL COMPONENTS OF THE STEEL FRAMING ARE FULLY INSTALLED. THE FLOOR SLABS AND ROOF DECKS ARE FULLY INSTALLED AND THE STEEL FRAME IS PROPERLY CONNECTED TO THE REINFORCED MASONRY SHEAR WALL.
- ALL MEP EQUIPMENT STEEL SUPPORTS SHALL BE COORDINATED WITH THE INSTALLING CONTRACTOR(S). SEE PLANS AND TYPICAL DETAILS FOR STEEL SUPPORT REQUIREMENTS.
- COORDINATE SIZE AND QUANTITY OF ROOF DECK PENETRATIONS WITH MEPPF DRAWINGS, TYP. REINFORCE NEW PENETRATIONS IN EXISTING NEW ROOF DECKS PER TYPICAL STRUCTURAL DETAILS.
- DESIGN AND DETAIL ANGLE CONNECTION TO THE TOP OF STEEL COLUMN AND TO THE ROOF JOIST TOP CHORD FOR AN AXIAL FORCE OF 3 KIPS. JOIST SUPPLIER/MANUFACTURER SHALL DESIGN THE STEEL JOIST TOP CHORD FOR THE AFORESAIDED ANGLE AXIAL FORCE.
- L4x4x5/8 HORIZ. ANGLE TO UNDERSIDE OF ROOF DECK, WELD DECK TO ANGLE, TYP.
- MAXIMUM LIVE LOAD DEFLECTION FOR 2ND FLOOR LEVEL = 1"
- SEE S0.1B FOR TYPICAL 2ND FLOOR SLAB REINFORCEMENT DETAIL AT GYMNASIUM EQUIPMENT ANCHORAGE LOCATIONS.
- P = $\frac{1}{4}$ KIPS REPRESENTS HORIZONTAL AXIAL SERVICE LEVEL FORCE IN THE ROOF MEMBER.

EXISTING TYPICAL CONCRETE BEAM SCHEDULE

COLUMN NOTATION	SIZE
1. COL. A	18"x18"
2. COL. B	12"x18"
3. COL. C	12"x12"
4. COL. D	12"x24"

BEAM NOTATION	SIZE
1. BM. A	18"x18"
2. BM. B	14"x20"
3. BM. C	16"x30"
4. BM. D	12"x28"
5. BM. E	12"x20"
6. BM. F	9"x18"
7. BM. G	14"x18"
8. BM. H	12"x24"
9. BM. I	12"x18"

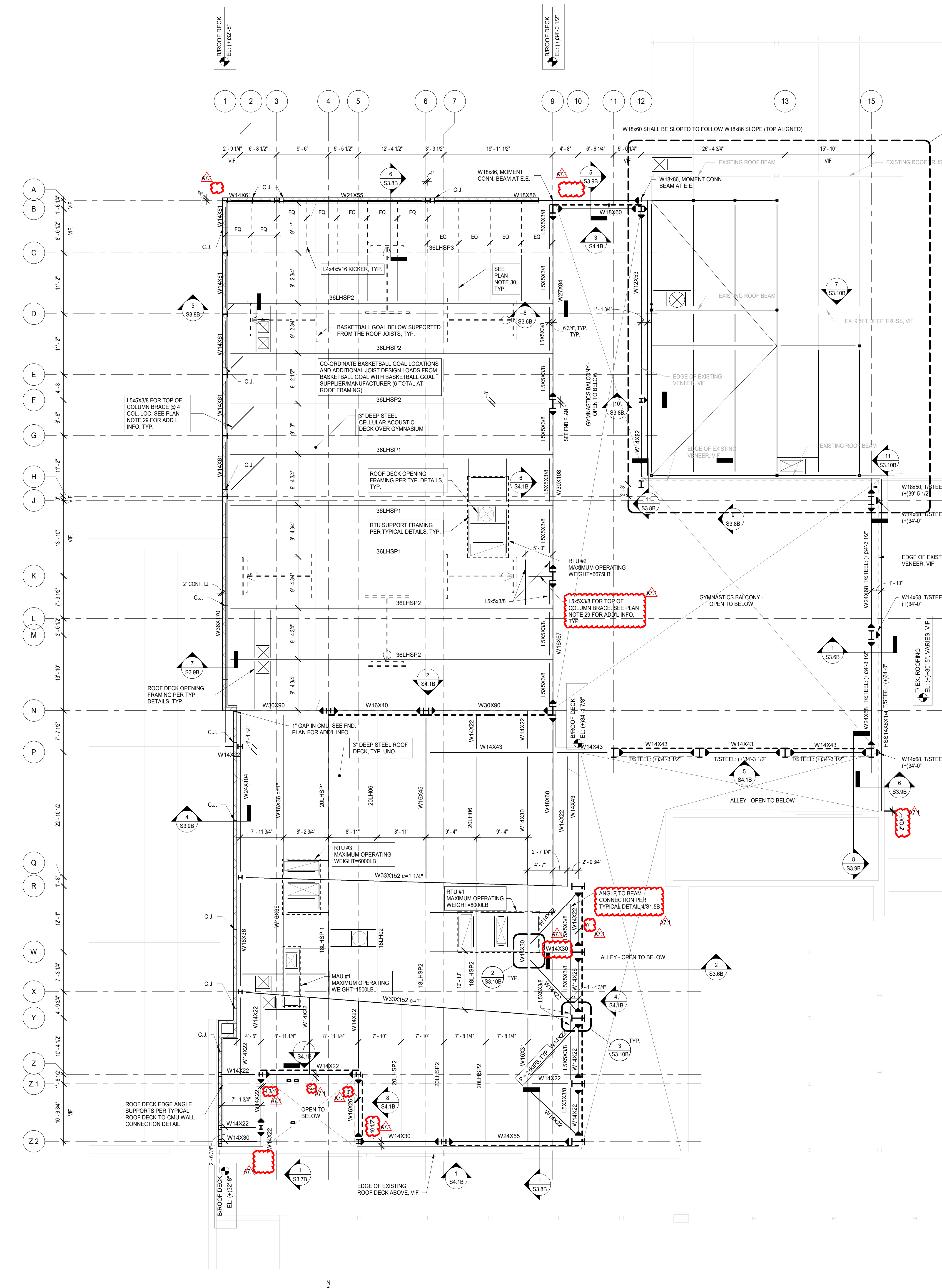

1 GYMNASIUM AND WRESTLING BALCONY ROOF FRAMING PLANS - PHASE B
SCALE: 1/8" = 1'-0"

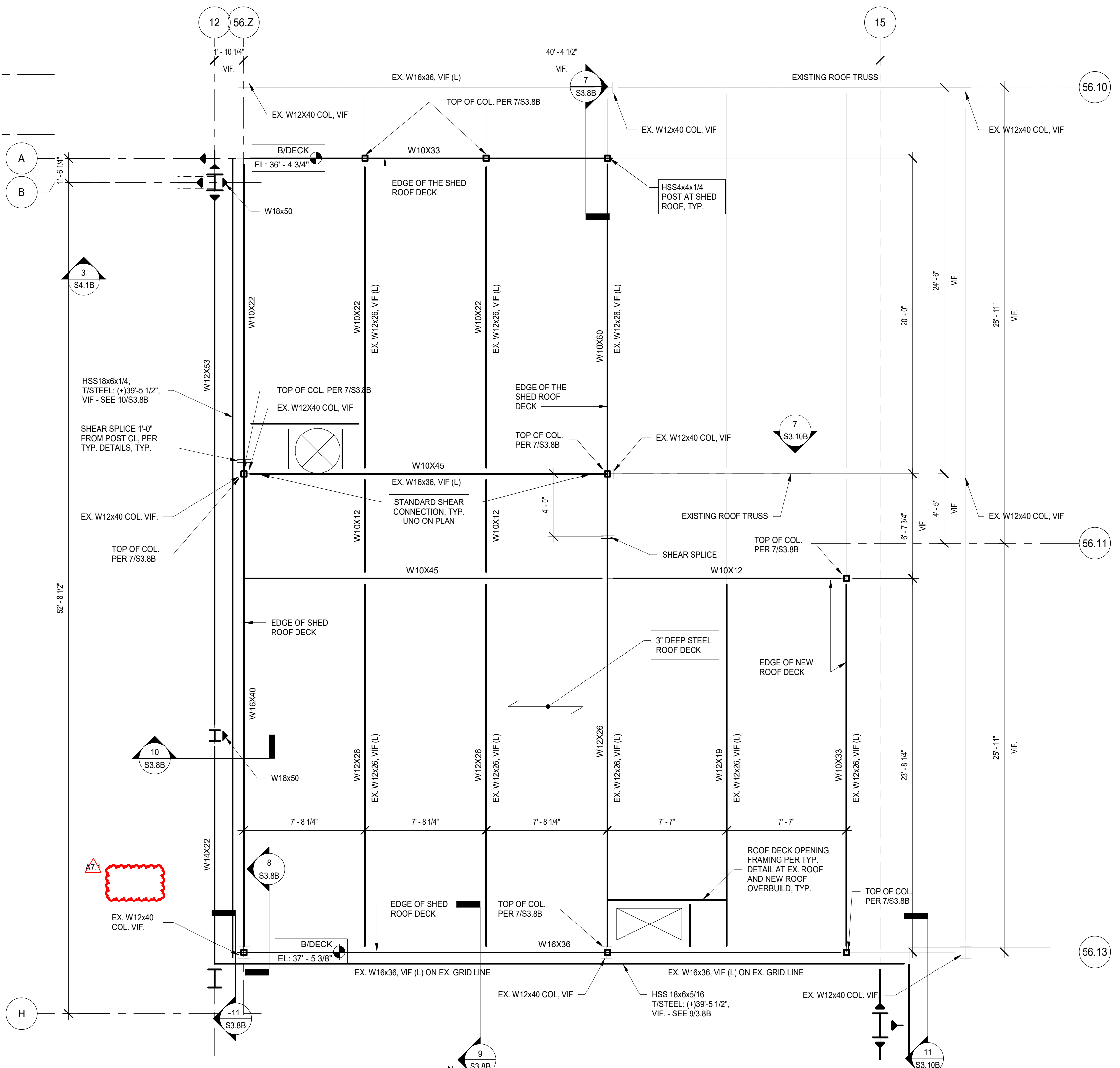

2 ENLARGED SHED ROOF FRAMING PLAN
SCALE: 1/4" = 1'-0"

NOT FOR CONSTRUCTION

REV	DESCRIPTION - PHASE B	DATE
AT.1	ISSUED FOR ADDENDUM AT.1 - BID GROUP 7	06.26.2019
	ISSUED FOR BID-BID GROUP 7	06.07.2019
	ISSUED FOR BID-BID GROUP 6	05.10.2019
	ISSUED FOR 75% CD - PHASE B	05.10.2019
	ISSUED FOR 50% CD - PHASE B	04.12.2019
	ISSUED FOR DESIGN DEVELOPMENT - PHASE B	03.11.2019

MFP IMPLEMENTATION - NORTH

4436 MAIN STREET
DOWNERS GROVE, IL 60515

GYM ROOF FRAMING PLAN - PHASE B

Project Number:
5274-42
Drawn By:
I.K.
Sheet:

6/25/2019 9:42:39 AM
 C:\Users\akumar\Documents\11-5274-42_DGN_Sheet_2019_Central_Arkham.dwg
 Wight & Co. © Copyright 2018 All rights reserved. No part of these documents may be reproduced, stored, transmitted in any form or by any means, electronic, mechanical, photocopying, recording or otherwise, without the prior written consent of Wight & Co.

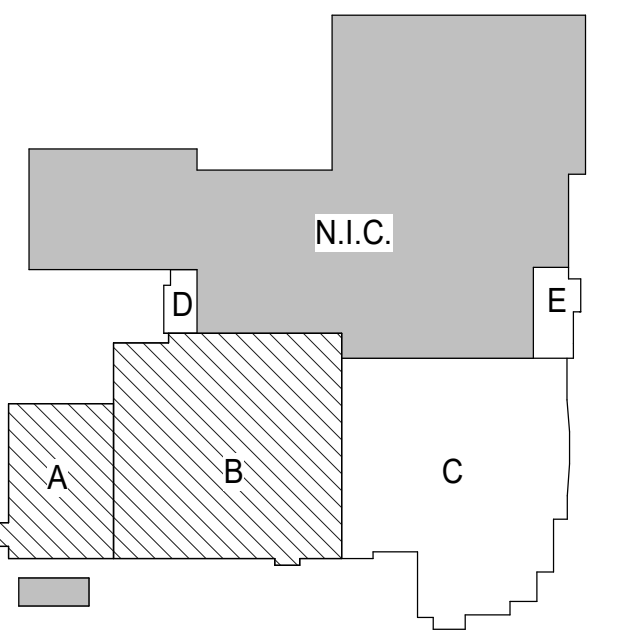

ELEVATED FLOOR AND ROOF LEVEL PLAN NOTES

- SEE S0 SERIES DRAWINGS FOR GENERAL NOTES, ABBREVIATIONS, SYMBOLS AND UNLIT SCHEDULES, AND STATEMENT OF SPECIAL INSPECTIONS.
- SEE S1 SERIES DRAWINGS FOR TYPICAL SECTIONS AND DETAILS.
- SEE S3 SERIES DRAWINGS FOR NON-TYPICAL SECTIONS AND DETAILS.
- SEE S4 SERIES DRAWINGS FOR SCHEDULES, ELEVATIONS AND DETAILS.
- CENTERLINE OF COLUMN IS ON GRIDLINE. TYPICAL UNLESS NOTED OTHERWISE.
- SEE PLANS FOR COLUMN ORIENTATION AND COLUMN CENTERLINE TO GRIDLINE DIMENSIONS FOR OFFSET COLUMNS.
- SEE PLANS FOR TOP OF ROUGH SLAB ELEVATION.
- (H) AS INDICATED ON PLAN INDICATES HIGHER BEAM OF FRAMING MEMBERS IN SAME VERTICAL PLANE.
- (L) AS INDICATED ON PLAN INDICATES LOWER BEAM OF FRAMING MEMBERS IN SAME VERTICAL PLANE.
- SEE ARCHITECTURAL DRAWINGS FOR CURBS NOT INDICATED (SIZE AND LOCATION). SEE TYPICAL SECTIONS AND DETAILS FOR CURB REINFORCEMENT.
- FLOOR DECK SHALL BE 3" THICK LIGHTWEIGHT CONCRETE OVER 2" DEEP COMPOSITE STEEL FLOOR DECK. REINFORCE SLAB WITH 4 LBS/CU. YD. OF STRU-X 9040 MACROSYNTHETIC FIBERS OR EQUIVALENT.
- SAW CUT 1/4" WIDE X 1/2" DEEP CONTROL JOINTS AT AREAS OF EXPOSED "SEALED CONCRETE" SLABS. LOCATE JOINTS AT COLUMN CENTERLINES AND 12 FEET CTS MAX AT REMAINDER.
- SEE PLAN FOR TOP OF SLAB ELEVATION. TYPICAL UNLESS NOTED OTHERWISE.
- VERIFY ELEVATOR MACHINE BEAM SIZES AND LOCATIONS WITH ELEVATOR SUPPLIER.
- SEE PLAN FOR BOTTOM OF STEEL ROOF DECK ELEVATIONS. TYPICAL UNLESS NOTED OTHERWISE.
- PROVIDE L4x4x8 STEEL ANGLE OR BENT PLATE AT ROOF PERIMETER AND AT INTERIOR OPENINGS IN ACCORDANCE WITH TYPICAL DETAILS.
- SEE S2.38 FOR SPECIAL DESIGN JOIST SCHEMATIC LOADINGS.
- SUSPEND PIPE HANGERS AND OTHER MECHANICAL EQUIPMENT FROM DESIGNATED OR APPROVED STEEL JOISTS. LOCATE CONCENTRATED LOADS AT JOIST PANEL POINTS ONLY OR REINFORCE STEEL JOISTS IN ACCORDANCE WITH TYPICAL SECTIONS AND DETAILS.
- PLACE SUPPORTS FOR ROOF TOP EQUIPMENT LOADS ON DESIGNATED OR APPROVED STEEL JOISTS. LOCATE CONCENTRATED LOADS AT JOIST PANEL POINTS ONLY OR REINFORCE STEEL JOISTS IN ACCORDANCE WITH TYPICAL SECTIONS AND DETAILS.
- SUPPORT ALL MEPP EQUIPMENT AND PIPING GREATER THAN 2 INCHES IN DIAMETER DIRECTLY FROM THE DESIGNATED STEEL ROOF JOISTS (TOP CHORDS ONLY) AND STEEL WIDE FLANGED BEAM AND GIRDER FRAMING. DO NOT SUPPORT THE AFORESAID FROM THE STEEL ROOF DECK DIRECTLY. ITEMS SUCH AS LIGHTWEIGHT CEILING AND LIGHTING MAY BE SUPPORTED DIRECTLY FROM THE STEEL ROOF DECK.
- AT THE NEW ADDITION, ALL ROOFS WITH THE STEEL ROOF DECKS ARE DESIGNED TO SUPPORT A MAXIMUM ALLOWED SUPERIMPOSED DEAD LOAD FROM THE PHOTOVOLTAIC BALLASTED SYSTEM OF 2 PSF PLUS THE ADDITIONAL DOWNWARD WIND PRESSURE FROM THE PHOTOVOLTAIC BALLASTED SYSTEM OF 3 PSF. SYSTEMS OTHER THAN THE PHOTOVOLTAIC BALLASTED SYSTEM ARE NOT PERMITTED.
- 2ND FLOOR COMPOSITE DECK SLAB SHALL RECEIVE TROWEL FINISH, PER SPECIFICATION SECTION 05300, SECTION 1.14. COORDINATE TROWELING AND FLOATING PROCEDURE WITH THE MACRO-SYNTHETIC FIBER SUPPLIER/MANUFACTURER.
- SEE STEEL DECK NOTES ON S0.18 FOR STEEL DECK ATTACHMENT INFORMATION TO THE SUPPORT STEEL.
- SEE THE GROUND FLOOR FOUNDATION PLAN FOR CMU WALL CONTROL JOINT LOCATIONS.
- MAXIMUM LIVE LOAD DEFLECTION FOR ROOF LEVEL @ BLDG ENVELOPE & INTERIOR PARTITIONS AS SHOWN ON ARCHITECTURE DRAWINGS = 1"
- THE NEW ADDITION STRUCTURE CONSISTS OF STEEL ROOF DECKS SUPPORTED ON STEEL JOIST, BEAM AND COLUMN FRAMING AND THE 2ND FLOOR COMPOSITE DECK SLAB SUPPORTED ON STEEL BEAM AND COLUMN FRAMING. THE VERTICAL LATERAL RESISTING SYSTEM CONSISTS OF STEEL BRACED FRAMES, STEEL MOMENT RESISTING MASONRY SHEAR WALLS. THE STEEL CONTRACTOR SHALL PROVIDE TEMPORARY BRACING TO THE STEEL FRAME UNTIL ALL COMPONENTS OF THE STEEL FRAMING ARE FULLY INSTALLED. THE FLOOR SLABS AND ROOF DECKS ARE FULLY INSTALLED AND THE STEEL FRAME IS PROPERLY CONNECTED TO THE REINFORCED MASONRY SHEAR WALL.
- ALL MEP EQUIPMENT STEEL SUPPORTS SHALL BE COORDINATED WITH THE INSTALLING CONTRACTOR(S). SEE PLANS AND TYPICAL DETAILS FOR STEEL SUPPORT REQUIREMENTS.
- COORDINATE SIZE AND QUANTITY OF ROOF DECK PENETRATIONS WITH MEPP DRAWINGS. TYP. REINFORCE NEW PENETRATIONS IN EXISTING NEW ROOF DECKS PER TYPICAL STRUCTURAL DETAILS.
- DESIGN AND DETAIL ANGLE CONNECTION TO THE TOP OF STEEL COLUMN AND TO THE ROOF JOIST TOP CHORD FOR AN AXIAL FORCE OF 5 KIPS. JOIST SUPPLIER/MANUFACTURER SHALL DESIGN THE STEEL JOIST TOP CHORD FOR THE AFORESAID ANGLE AXIAL FORCE.
- L4x4x8 HORIZ. ANGLE TO UNDERSIDE OF ROOF DECK. WELD DECK TO ANGLE. TYP.
- MAXIMUM LIVE LOAD DEFLECTION FOR 2ND FLOOR LEVEL = 1"
- SEE S51.58 FOR TYPICAL 2ND FLOOR SLAB REINFORCEMENT DETAIL AT GYMNASIUM EQUIPMENT ANCHORAGE LOCATIONS.
- P = KIPS REPRESENTS HORIZONTAL AXIAL SERVICE LEVEL FORCE IN THE ROOF MEMBER.

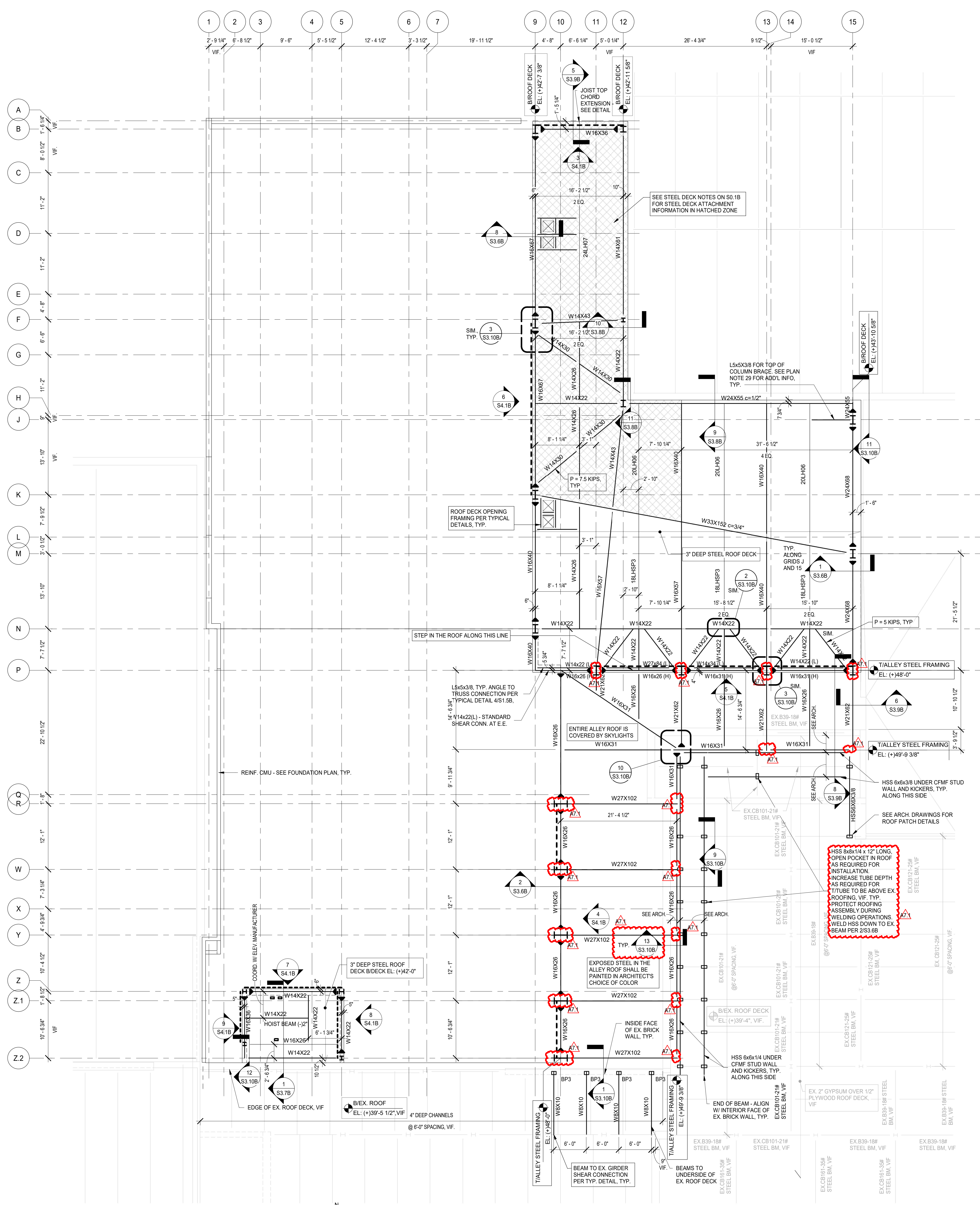

1 ATHLETIC AND ALLEY ROOF FRAMING PLANS - PHASE B
SCALE: 1/8" = 1'-0"

**NOT FOR
CONSTRUCTION**

REV	ISSUE	DATE
A7.1	ISSUED FOR ADDENDUM A7.1 - BID GROUP 7	06.26.2019
	ISSUED FOR BID-BID GROUP 7	06.07.2019
	ISSUED FOR BID-BID GROUP 6	05.10.2019
	ISSUED FOR 75% CD - PHASE B	05.10.2019
	ISSUED FOR 50% CD - PHASE B	04.12.2019
	ISSUED FOR DESIGN DEVELOPMENT - PHASE B	03.11.2019

**MFP
IMPLEMENTATION -
NORTH**

4436 MAIN STREET
DOWNERS GROVE, IL 60515

**ATHLETIC AND ALLEY
ROOF FRAMING PLANS -
PHASE B**

Project Number:
5274-42
Drawn By:
J.G.
Sheet:

6/25/2019 9:44:05 AM
 C:\Users\jgallagher\Documents\11-5274-42_DGN_Sheet_2019_Central_Abbreviations.rvt
 Wight & Co. © Copyright 2019. All rights reserved. No part of these documents may be reproduced, stored, or transmitted in any form or by any means, electronic, mechanical, photocopying, recording or otherwise, without the prior written consent of Wight & Co.

**NOT FOR
CONSTRUCTION**

A7.1	ISSUED FOR ADDENDUM A7.1 - BID GROUP 7	06.26.2019
A6.1	ISSUED FOR ADDENDUM A6.1 - BID GROUP 6	05.31.2019
	ISSUED FOR BID-BID GROUP 6	05.10.2019
	ISSUED FOR 75% CD - PHASE B	05.10.2019
REV	ISSUE	DATE

MFP IMPLEMENTATION - NORTH

4436 MAIN STREET
DOWNERS GROVE, IL 60515

NON-TYPICAL SECTIONS AND DETAILS

Project Number:
5274-42
Drawn By:
I.K.
Sheet:

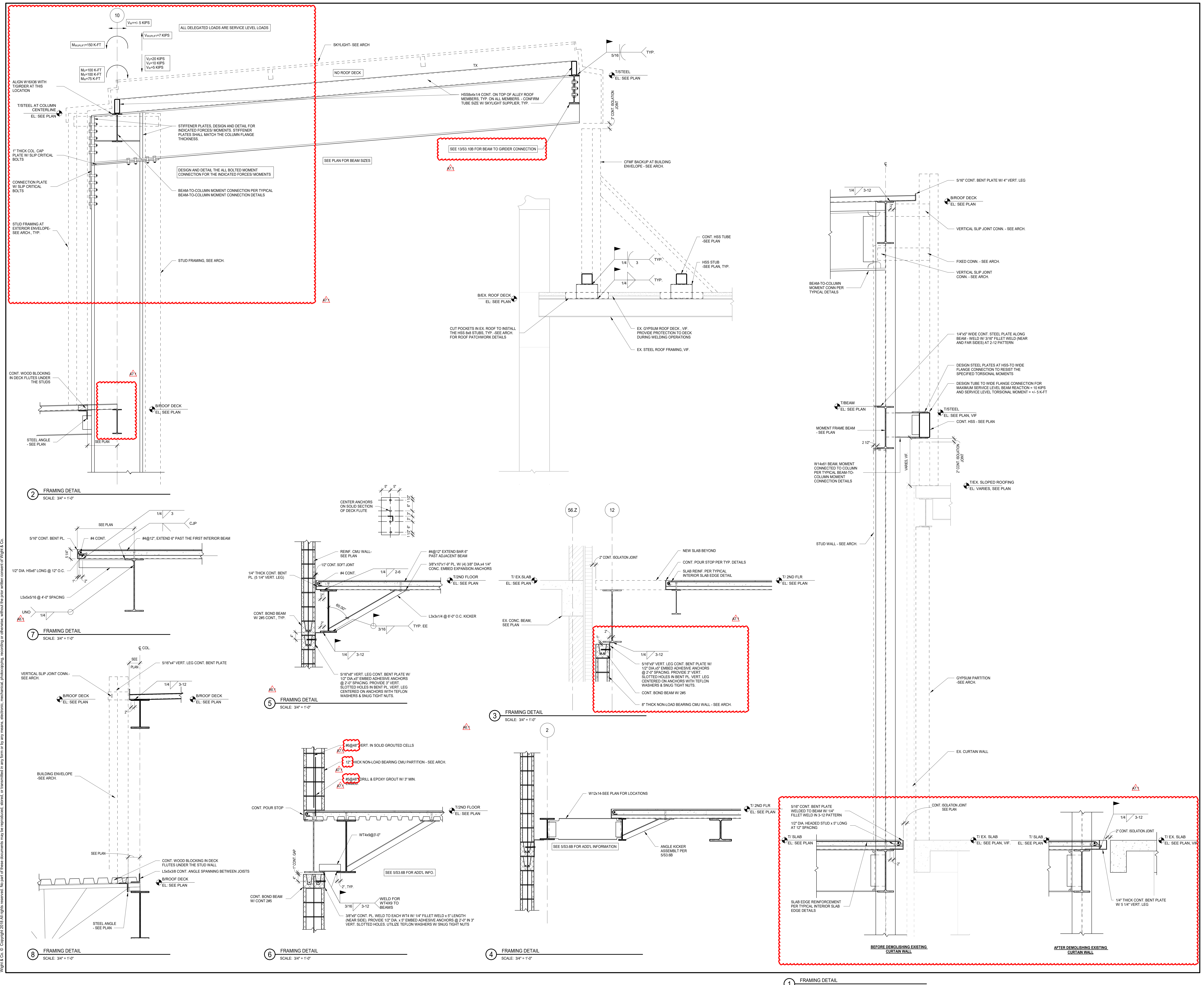

6/25/2019 9:31:05 AM
 C:\Users\skubank\Documents\11-5274-42_DCN_Shec_2019_Central_Architects.dwg
 Wight & Co. © Copyright 2019 All rights reserved. No part of these documents may be reproduced, stored, or transmitted in any form or by any means, electronic, mechanical, photocopying, recording or otherwise, without the prior written consent of Wight & Co.

NOT FOR
CONSTRUCTION

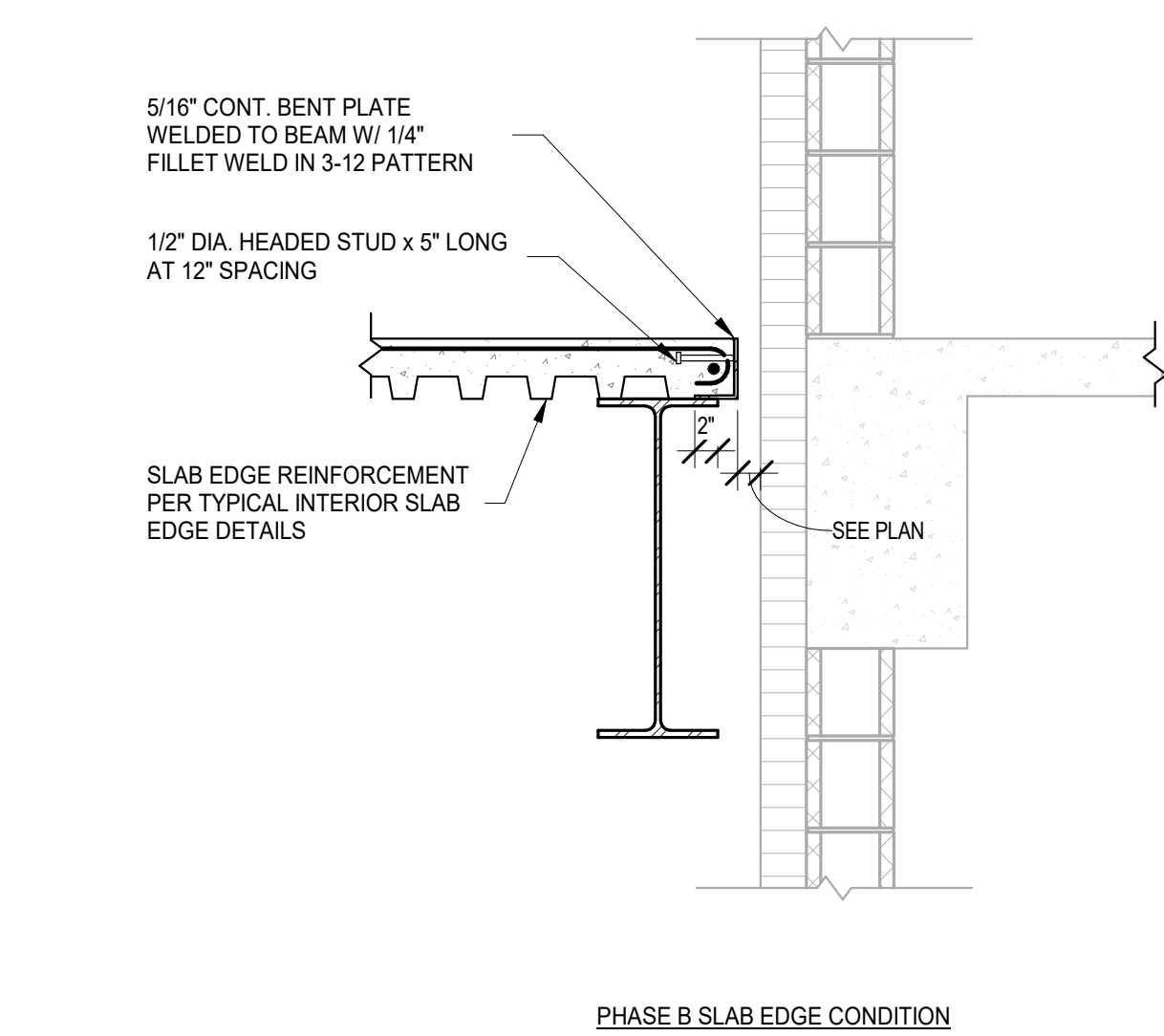
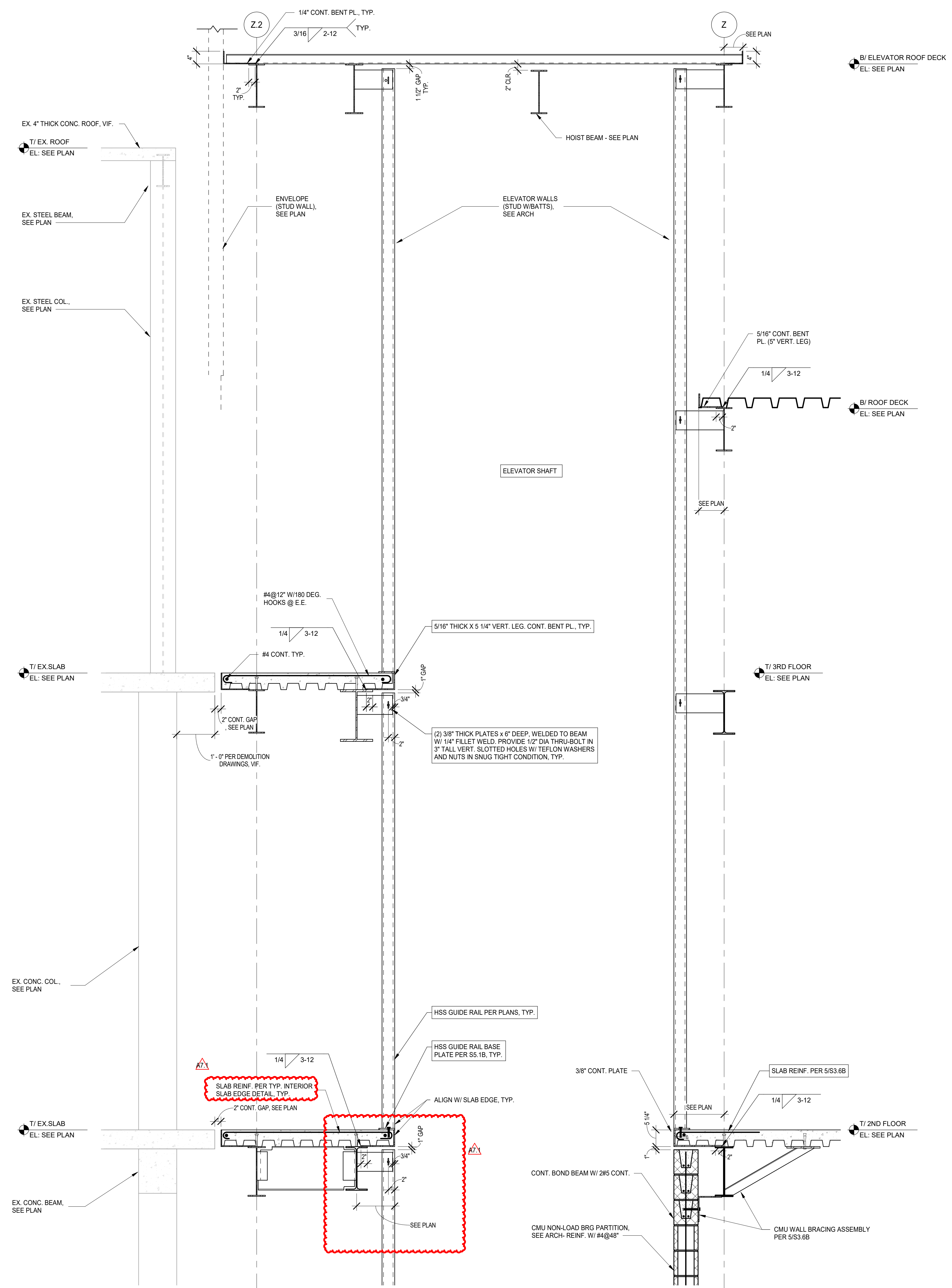

4 FRAMING DETAIL
SCALE: 3/4" = 1'-0"

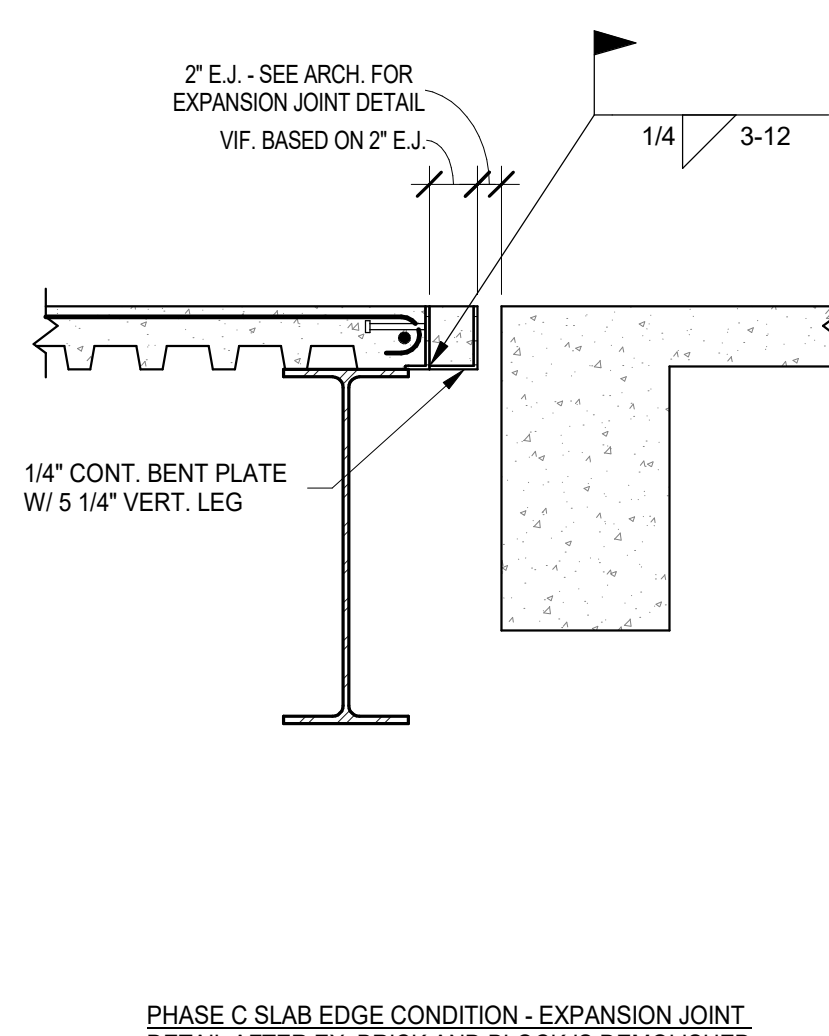

5 FRAMING DETAIL
SCALE: 3/4" = 1'-0"

1 FRAMING DETAIL
SCALE: 3/4" = 1'-0"

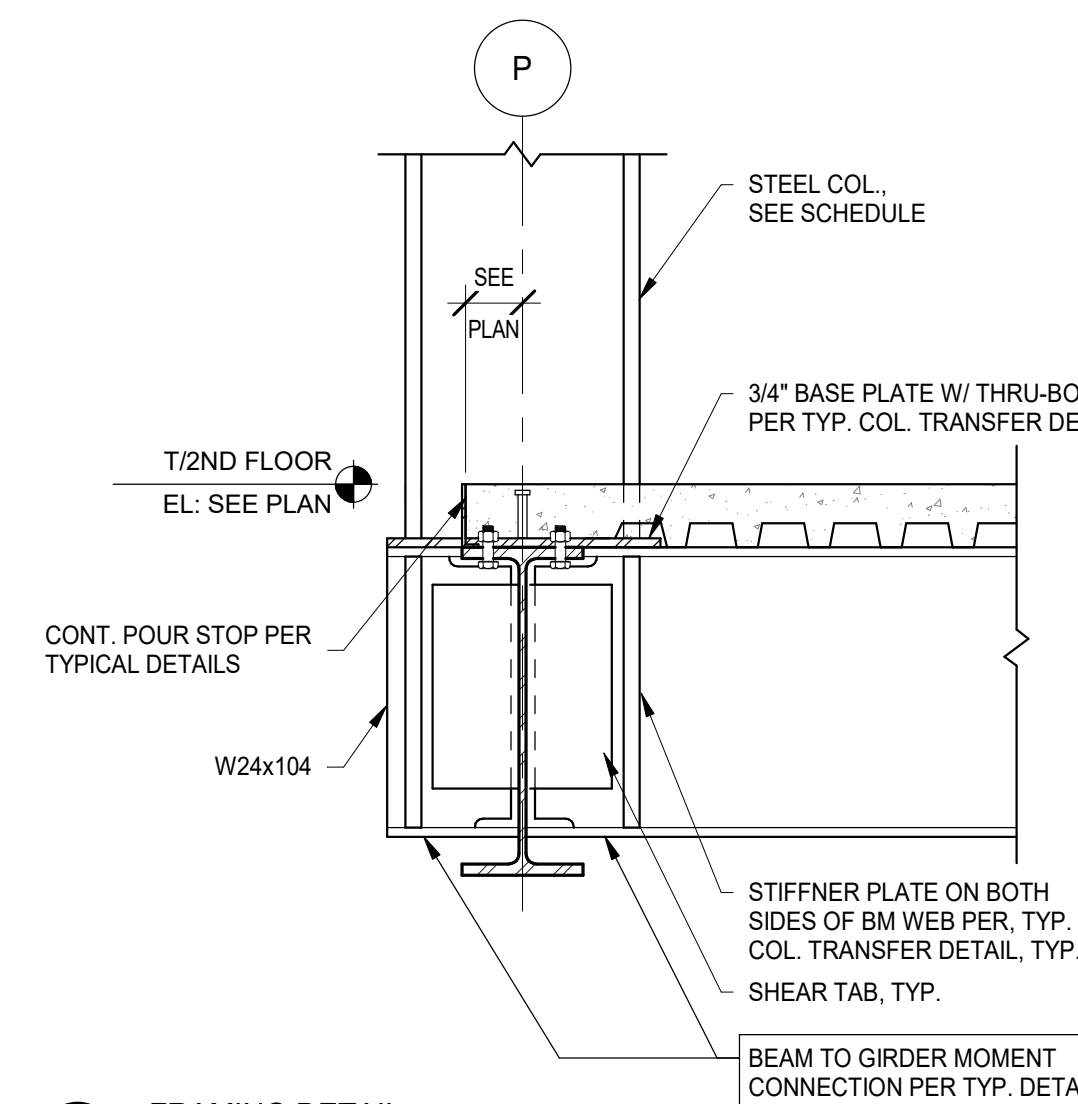

3 FRAMING DETAIL
SCALE: 3/4" = 1'-0"

2 FRAMING DETAIL
SCALE: 3/4" = 1'-0"

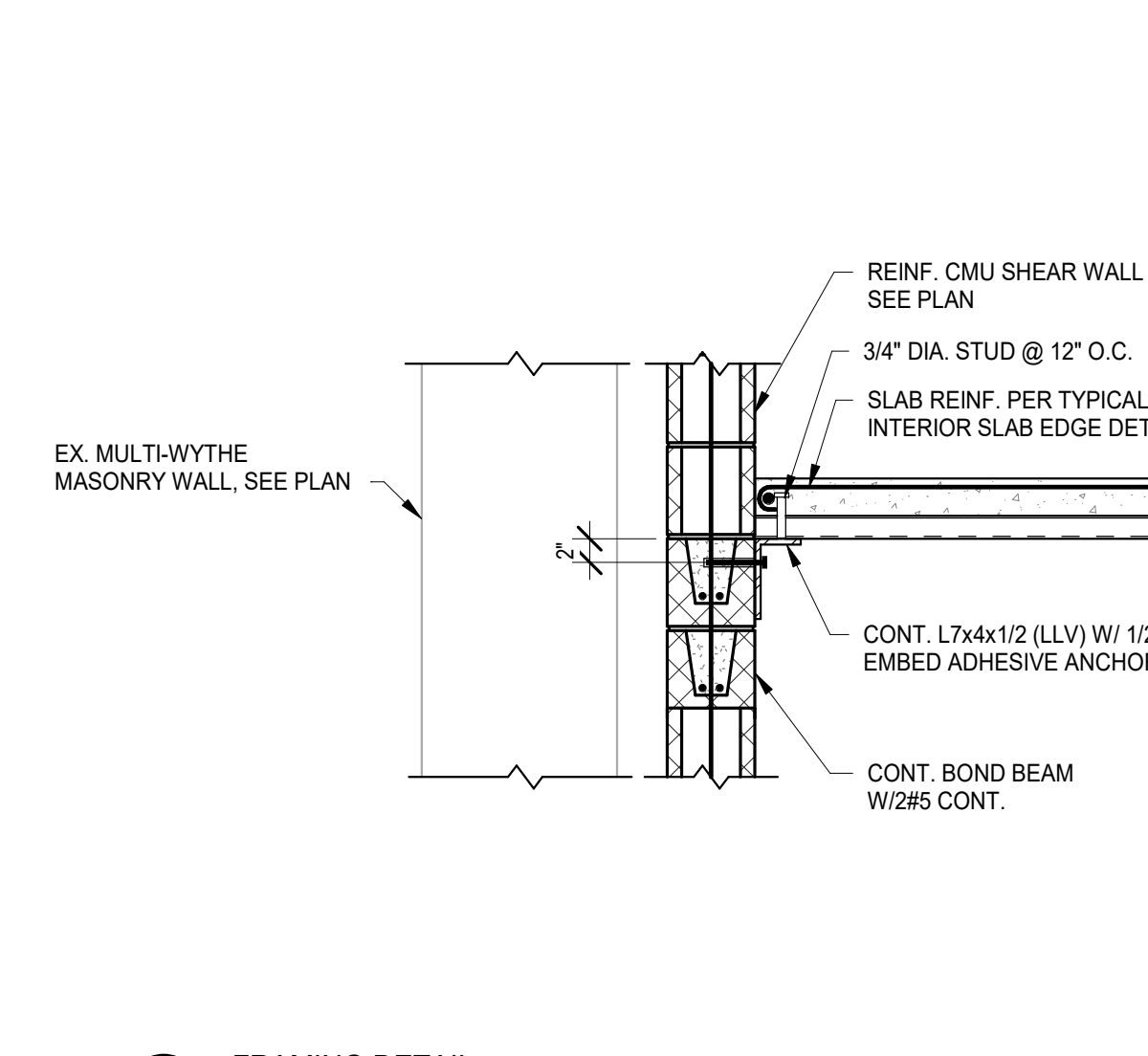

A7.1 ISSUED FOR ADDENDUM A7.1 - BID GROUP 7 06.26.2019
ISSUED FOR BID-BID GROUP 7 06.07.2019
REV. ISSUE DATE

MFP IMPLEMENTATION - NORTH

4436 MAIN STREET
DOWNERS GROVE, IL 60515

NON-TYPICAL SECTIONS AND DETAILS

Project Number: 5274-42
Drawn By: I.K.
Sheet:

6/25/2019 3:21:15 PM C:\Users\skabam\Documents\11-5274-42_DGN_Shec_2019_Central_Aulabam.rvt Wight & Co. © Copyright 2018 All rights reserved. No part of these documents may be reproduced, stored, or transmitted in any form or by any means, electronic, mechanical, photocopying, recording or otherwise, without the prior written consent of Wight & Co.

**NOT FOR
CONSTRUCTION**

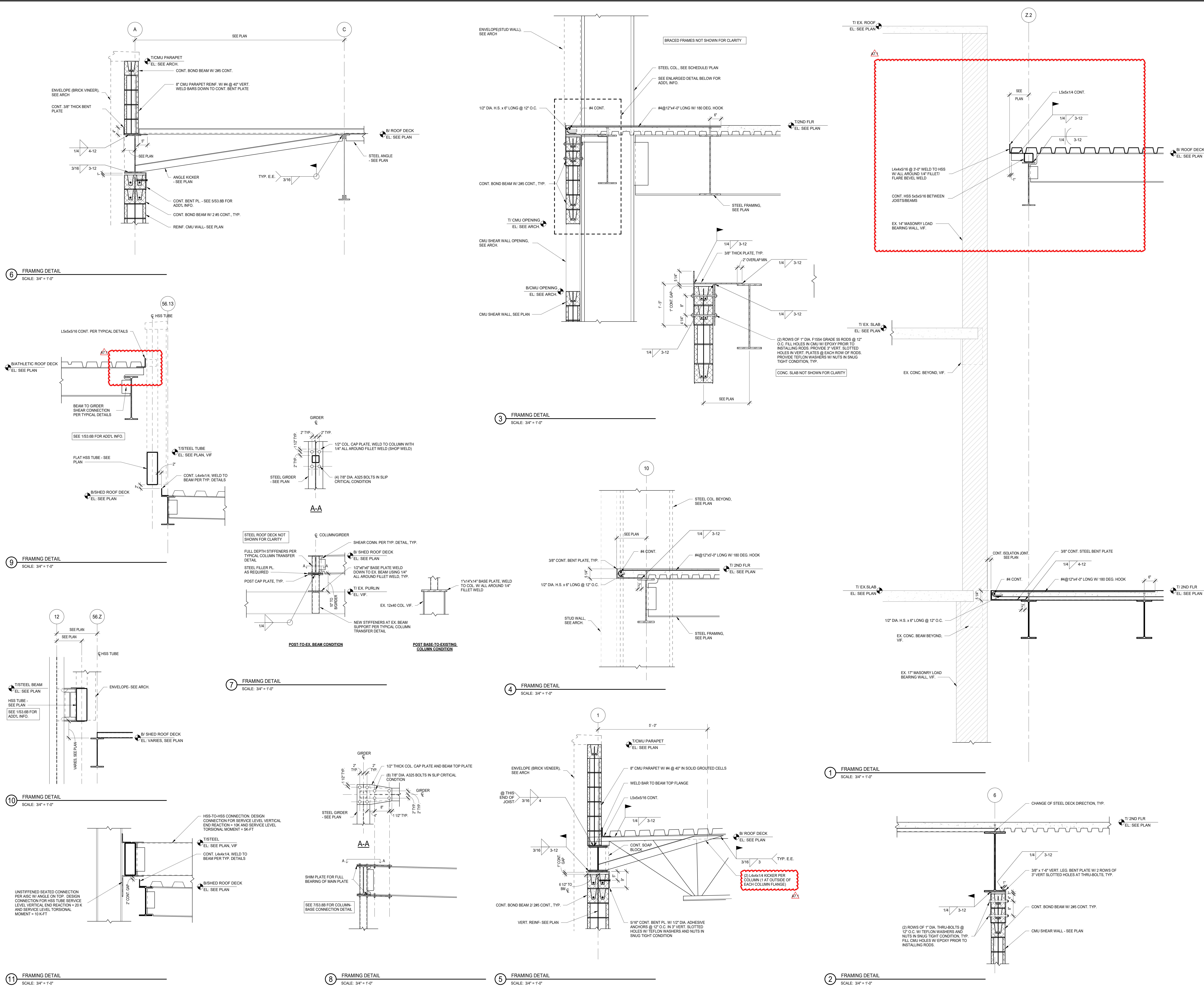

A7.1 ISSUED FOR ADDENDUM A7.1 - BID GROUP 7 06.26.2019
ISSUED FOR BID-BID GROUP 7 06.07.2019
REV. DATE

**MFP
IMPLEMENTATION -
NORTH**

4436 MAIN STREET
DOWNERS GROVE, IL 60515

**NON-TYPICAL SECTIONS
AND DETAILS**

Project Number:
5274-42
Drawn By:
I.K.
Sheet:

6/25/2019 9:31:18 AM
 C:\Users\skm\Documents\11-5274-42_DGN_Sheet_2019_Central_Architectural\11-5274-42_DGN_Sheet_2019_Central_Architectural.dwg
 Wight & Co. © Copyright 2018 All rights reserved. No part of these documents may be reproduced, stored, or transmitted in any form or by any means, electronic, mechanical, photocopying, recording or otherwise, without the prior written consent of Wight & Co.

**NOT FOR
CONSTRUCTION**

6/25/2019 9:31:37 AM
 C:\Users\skabam\Documents\11-5274-42_DCN_Shec_2019_Central_Architectural\11-5274-42_DCN_Shec_2019_Central_Architectural.rvt
 Wight & Co. © Copyright 2018 All rights reserved. No part of these documents may be reproduced, stored, or transmitted in any form or by any means, electronic, mechanical, photocopying, recording or otherwise, without the prior written consent of Wight & Co.

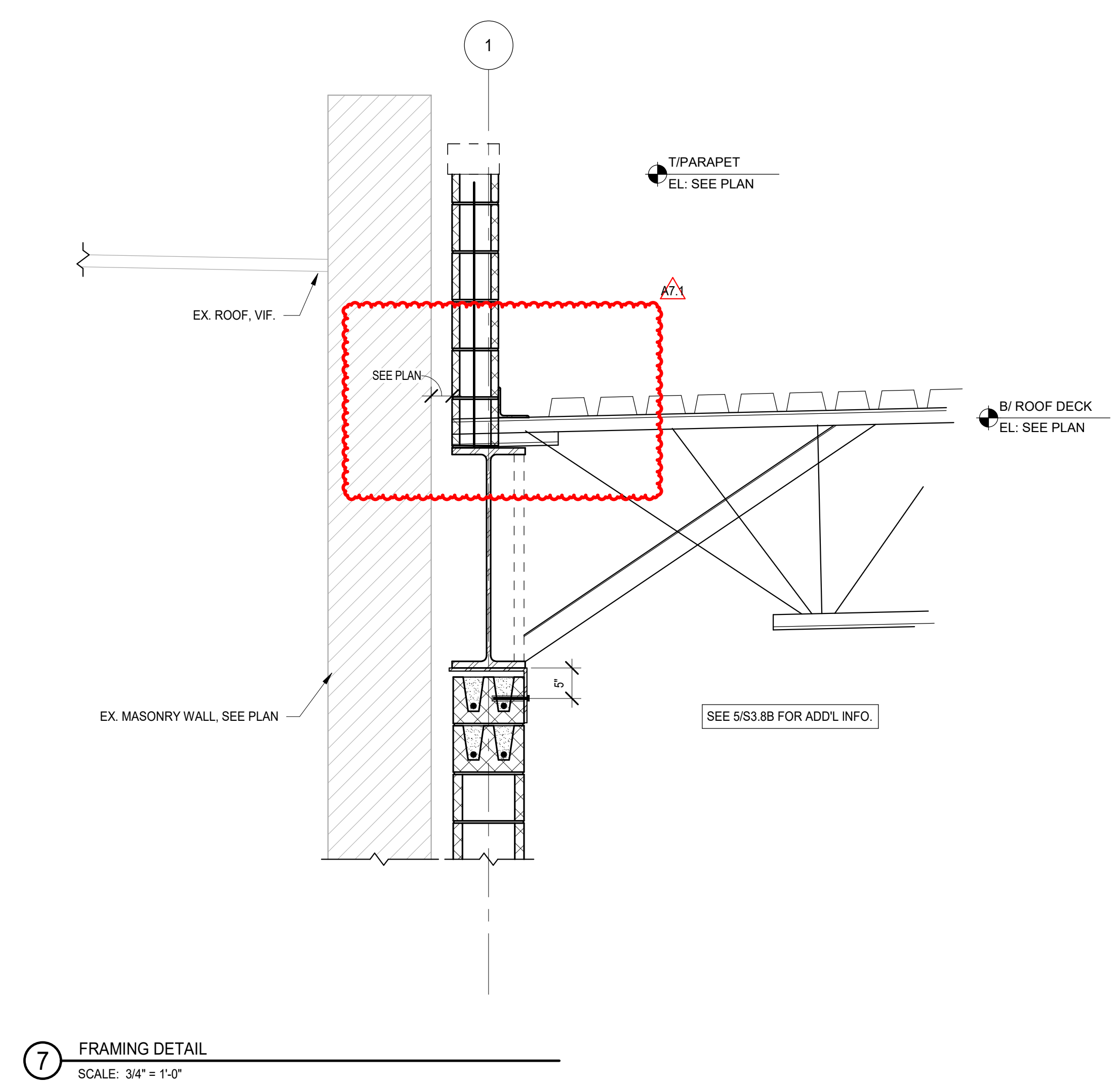

7 FRAMING DETAIL
SCALE: 3/4" = 1'-0"

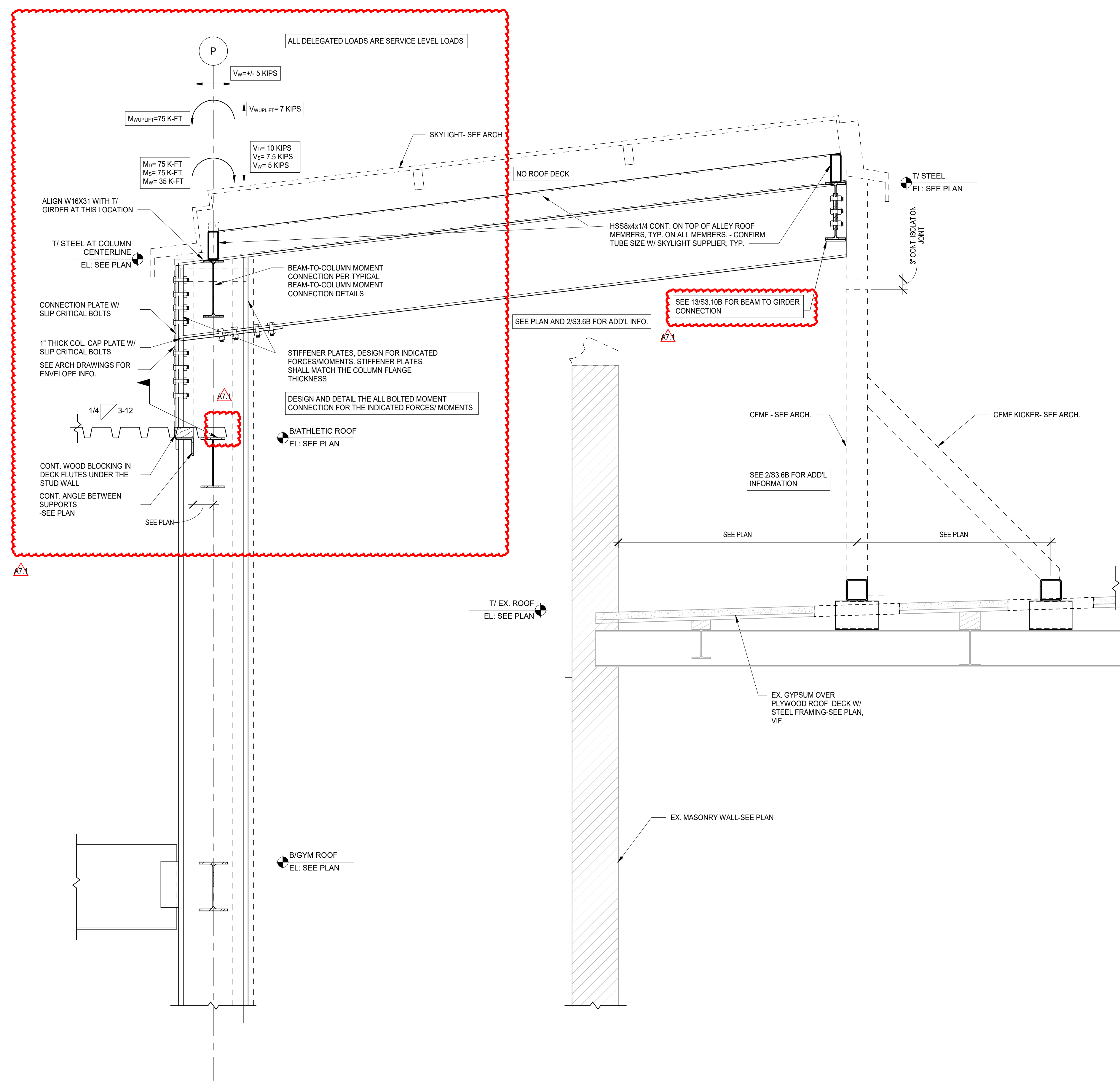

8 FRAMING DETAIL
SCALE: 3/4" = 1'-0"

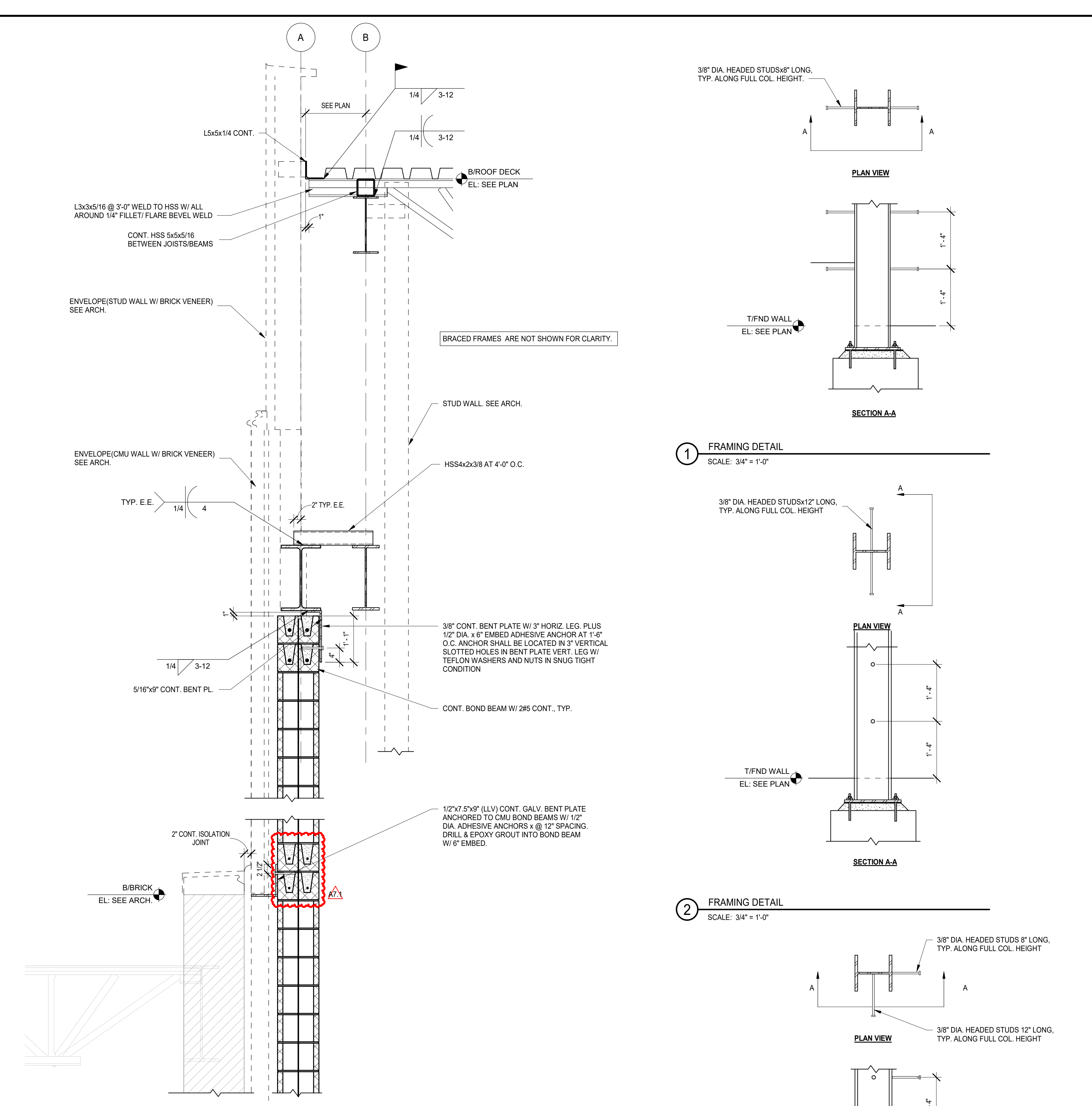

1 FRAMING DETAIL
SCALE: 3/4" = 1'-0"

2 FRAMING DETAIL
SCALE: 3/4" = 1'-0"

3 FRAMING DETAIL
SCALE: 3/4" = 1'-0"

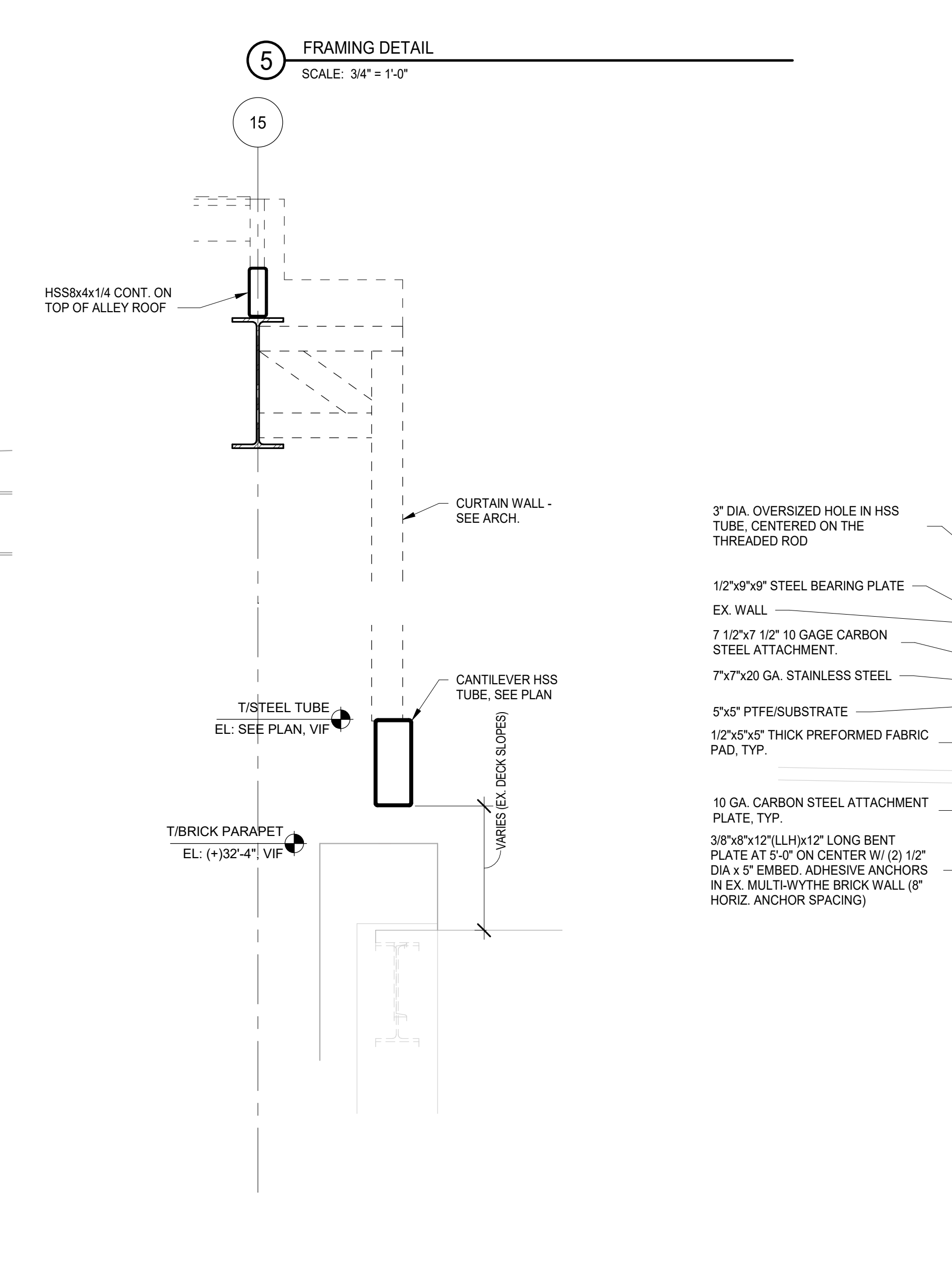

5 FRAMING DETAIL
SCALE: 3/4" = 1'-0"

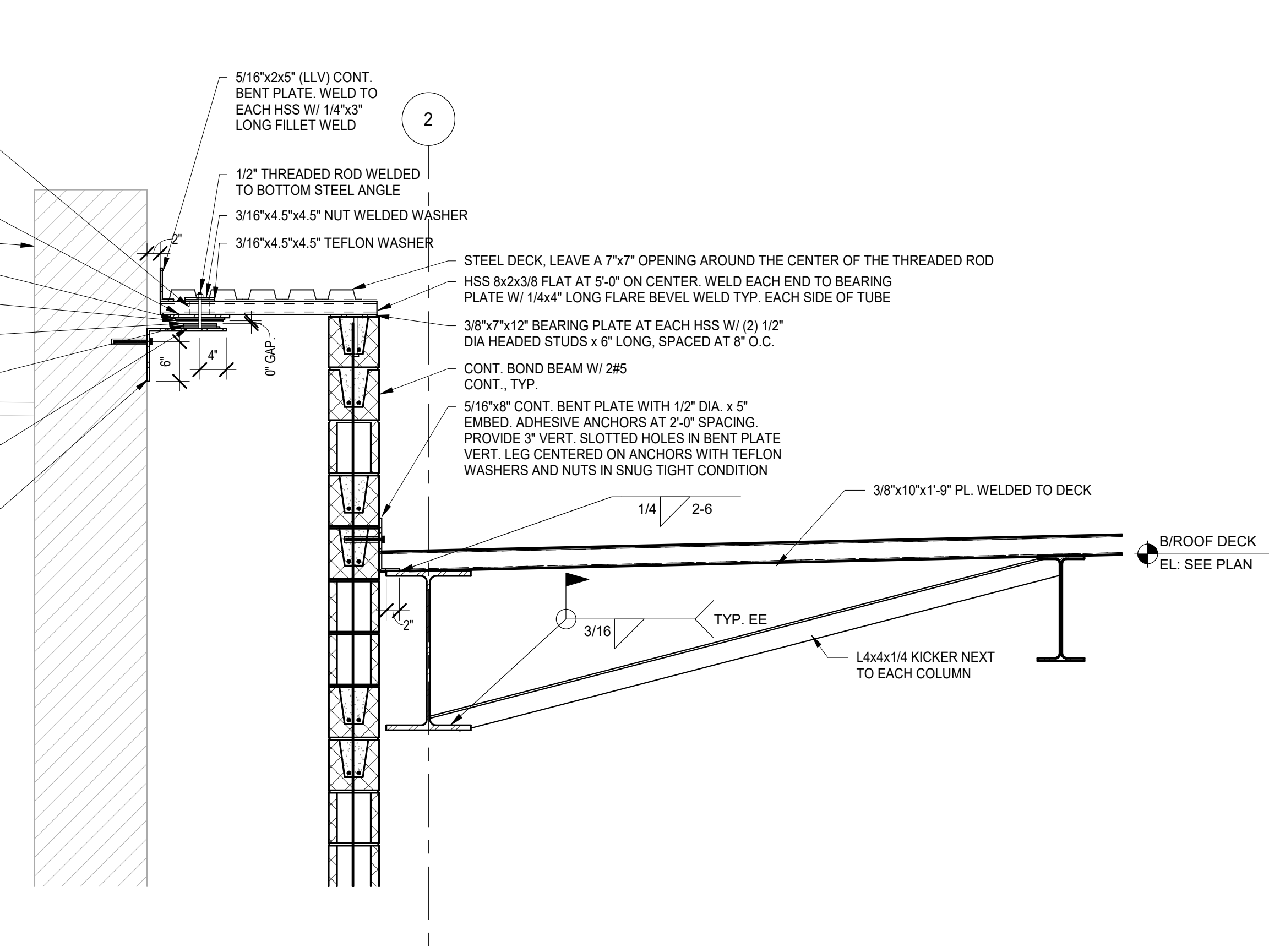

6 FRAMING DETAIL
SCALE: 3/4" = 1'-0"

A7.1 ISSUED FOR ADDENDUM A7.1 - BID GROUP 7 06.26.2019
ISSUED FOR BID-BID GROUP 7 06.07.2019
REV. ISSUE DATE

**MFP
IMPLEMENTATION -
NORTH**

4436 MAIN STREET
DOWNERS GROVE, IL 60515

**NON-TYPICAL SECTIONS
AND DETAILS**

Project Number:
5274-42
Drawn By:
I.K.
Sheet:

S3.9B

