



DATE: January 28, 2020

FROM: Wight & Company
2500 N. Frontage Road
Darien, IL 60561

SUBJECT: ADDENDUM #1 TO THE BIDDING DOCUMENTS FOR:
BID GROUP #9
MASTER FACILITY PLAN IMPLEMENTATION
COMMUNITY HIGH SCHOOL DISTRICT 99
1436 NORFOLK STREET
DOWNERS GROVE, IL 60516

Wight & Company
wightco.com
.....
2500 North Frontage Road
Darien, IL 60561
.....
P 630.969.7000
F 630.969.7979

This addendum forms a part of the Bidding Contract Documents, dated November 20, 2019. Bidders must acknowledge receipt of this Addendum in the space provided on the Bid Form. Drawing revisions clouded and tagged with delta 33.

Bid Package #106 – Millwork -is eliminated from BG#9 South MFP.

SOUTH

- I. **Bid Forms:** BP#105 Flooring, BP#107 Acoustical Ceilings and Wall Panels, BP#109 Theatre Shells, BP#110 Theatre Platforms, BP#111 Theatre Rigging, and BP#114 Landscaping
- II. **Scope of Work** BP#105 Flooring, BP#107 Acoustical Ceilings and Wall Panels, BP#109 Theatre Shells, BP#110 Theatre Platforms, BP#111 Theatre Rigging, and BP#114 Landscaping.
- III. **Landscaping Drawings:** Attached
- IV. **Landscaping Specifications:** Attached

END OF ADDENDUM

BID DATE: February 7th, 2020 at 1:00 p.m. (CST)
(as date/time stamped by District 99's Receptionist)

BID TO: Community High School District 99
Administrative Center
6301 Springside Avenue
Downers Grove, IL 60516

RECEIVED BY:

BID FROM: _____

BID FOR: ***Bid Group #9 Bid Package #105 Flooring
Phase C***

South High School
1436 Norfolk Street
Downers Grove, IL 60516

It is required to have one original and one copy of your bid form.

THE UNDERSIGNED:

Acknowledges receipt of:

Plans and specifications for the work indicated above.

Addenda: No. _____ dated _____
No. _____ dated _____
No. _____ dated _____
No. _____ dated _____

Having examined the site of the work, and having familiarized himself or herself with local conditions affecting the cost of the work and with all requirements of the bidding documents including Instructions to Bidders, drawings, specifications and duly issued addenda as prepared by the architect, Wight & Company, hereby agrees to perform all work and furnish all labor, material and equipment specifically required of him by the bidding documents and such additional work as may be included as related requirements in other divisions or sections of the specifications, exclusive of alternate bids.

Agrees:

To furnish and install the described material and/or services for stated lump sum price.

To hold this bid open until **90** calendar days after bid opening date.

DIVISION 0 – BIDDING & CONTRACT REQUIREMENTS
SECTION 03105 - BID FORM

To accept the provisions of the General Provisions (Project Manual Division 0 – Bidding & Contracting Requirements Section 00201) and disposition of bid security.

To enter into and execute a contract with the Owner, if awarded on the basis of this bid, and in connection therewith to:

1. Furnish all bonds and insurance required by the bidding documents.
2. Accomplish the work in accordance with the contract.
3. Complete the work within the contract time herein specified.

Completion Time:

The undersigned agrees to begin construction immediately, or as directed by the Construction Manager, upon notice of contract award and to perform the following components of the work in accordance with the Construction Manager's Construction. This schedule is bound in the Project Manual. See attached scope of work in section 0300.

SCOPE OF WORK:

The work in this agreement (without additional compensation) shall include, but shall not necessarily be limited to, all skilled labor, supervision, premium time, materials, tools, equipment, plant, supplies, samples, shop drawings, design/engineering drawings, layout, transportation, supervision, contributions, insurance, taxes (if applicable), compliance with all agencies (City / Village, County, State, Federal and/or any other jurisdictional agency, as may be required) and/or all services and facilities necessary and/or required for the performance of all Work shown, detailed, and/or implied by the following documents and as defined herein.

It is understood that this Trade Contractor shall perform the Work for a complete and operational system as indicated or implied in all Contract Documents. It is recognized and understood that the documents upon which the bid is based are at a conceptual phase and this Contractor who has certain skills and judgments based upon his knowledge of techniques, procedures, systems, general state of the art of his specialty is expected to include in the scope of work, all items required in order to carry out a complete and functional system whether or not shown or described in the contract documents. This contract will be awarded on the basis of such documents with the understanding that this contractor is to furnish and install all items required for the proper completion of this work without adjustment to this contract price. No extra payments shall be made of claims entertained as a result of such items, unless it can be clearly demonstrated to be added scope to the contract and beyond the original intent of the documents.

Contractor to provide all Trade Contract work referenced in:

1. Any sheet of this bid group package including (reference Division 0 – Bidding and Contract Requirements, Section 00200 – Notice to Bidders).
2. Specification 00300 Bid Packages Scope Document.

WORK BASE BID: For providing all work including all allowances as required for the completion of the construction of the base bid project as shown on the drawings and specifications and NOT including alternate bids and/or contractor's proposed alternates and substitutes.

BASE BID

TOTAL BASE BID AMOUNT SOUTH HIGH SCHOOL MASTER FACILITY PLAN

_____ Dollars (\$ _____)

1. This TRADE CONTRACTOR shall include an allowance of **\$110,000.00 in their base bid** for floor prep and leveling and moisture mitigation. Contract amounts will be adjusted by change order for amounts greater or less than the allowance. Allowance to be utilized only at the direction of Construction Manager.
2. This TRADE CONTRACTOR shall provide **Unit Pricing** / S.F. for additional Flooring Leveling, if necessary, due to unforeseen conditions. Unit Pricing shall include all labor and material. Unit Pricing to be placed in designated location on Bid Form.

_____ Dollars (\$ _____)

3. This TRADE CONTRACTOR shall provide **Unit Pricing** / S.F. for Flooring mitigation, if necessary, due to failed alkalinity or moisture tests. Unit Pricing shall include all labor and material. Unit Pricing to be placed in designated location on Bid Form.

_____ Dollars (\$ _____)

BONDS:

This TRADE CONTRACTOR will be required to provide a Performance and Payment Bond for their work in accordance with 00201 of the General Conditions.

Award Basis:

The project will be awarded based upon the attached Evaluation Criteria, Section 301a. Owner and Construction Manager alternate's may be considered to find the most qualified bidder if the result of combining the base bid and the selected alternate(s) is the most qualified bid, and is to the benefit of the owner.

Each of the following amounts for alternate construction includes the entire cost of such construction, except as otherwise noted. Acceptance of any or all of the alternates for inclusion in the contract is the sole prerogative of the owner.

All additional costs due to the alternates are included in the amount to be added to the base bid, so that no additional costs will be borne by the owner due to acceptance of alternates. This alternate price is not to be included in the base bid price.

Owner Requested Alternates:

Each of the following amounts for alternate construction includes the entire cost of such construction, except as otherwise noted. Acceptance of any or all of the alternates for inclusion in the contract is the sole prerogative of the owner.

All additional costs due to the alternates are included in the amount to be added to the base bid, so that no additional costs will be borne by the owner due to acceptance of alternates.

Proposed Alternates: (Contractors Proposed Alternates)

	Item Specified	Proposed Alternate	Change in Bid Price
1.	_____	_____	_____
2.	_____	_____	_____
3.	_____	_____	_____

Owner Requested Unit Prices/Allowances (as applicable to this Trade Contractor's scope of work) (additive or deductive).

This trade contractor includes _____ dumpsters for all refuse caused by this trade contractor's work in the amount of _____ Dollars (\$ _____) Note: trade contractors are to include in their bid form submittal the quantity of dumpsters required to complete their work and the cost associated with same. Dumpster costs will be subtracted by change order. Dumpsters will be procured and managed by Construction Manager. Note: Dumpster use in excess of that proposed by this Trade Contractor will be adjusted by back charge.

Owner Requested Scheduling Information:

Note: The work of this Trade Contractor is to be completed in accordance with the overall project schedule as identified elsewhere in this project manual and/or as subsequently directed by Construction Manager. This Trade Contractor shall submit a proposed submittals list/schedule/material log within five (5) calendar days of Notice To Proceed.

1. Shop drawings / Submittal for this trade contractor will be submitted within 10 calendar days of receipt of notice to proceed.

Bid Acceptance:

If written notice of the acceptance of this bid is mailed, telegraphed or delivered to the undersigned within the time noted herein, after the date of opening of bids or at any time thereafter before this bid is withdrawn, the undersigned agrees that he will execute a construction contract in accordance with the bids as accepted.

The Owner reserves the right to award the contract to its best interests, review and accept any and all value engineering alternatives, negotiate with the lowest responsible bidder, to reject any or all bids, to waive any informalities in bidding and to hold all bids for the bid guarantee period. The Owner reserves the right to award separate contracts for any of the items of work bid herein.

Bid Deposit:

The undersigned furnishes herewith, as required in the Instructions to Bidders, a bid deposit in the amount of ten percent (10%) of the amount bid in the form of Cashier's Check, or Certified Check, made payable to the Owner or Bid Bond, naming the Owner as obligee. (Bidder to check form of deposit furnished.)

It is understood and agreed that should the undersigned fail to enter into a contract with the Owner or furnish acceptable contract security within the time and in the manner herein provided, the bid deposit shall be retained by the Owner as liquidated damages and not as a forfeiture. As it is impossible to determine precisely an exact amount of damages the Owner will sustain, it is agreed that the bid deposit is a fair and equitable estimate of such damages.

REPRESENTATIONS AND CERTIFICATIONS:

The bidder makes the following representations and certifications as part of his bid on the project herein identified in the Bid Form. In the case of a joint venture bid, each party represents and certifies as to his own organization.

AVAILABILITY. The number and amount of contracts and awards pending which I am and/or will be obligated to perform, now and during the course of the project, will not interfere with or hinder the timely prosecution of my work.

SURETY. I have notified a Surety Company that I am submitting a bid for work to be performed on the project. The Surety Company has agreed to issue a performance and labor and material payment bond for my work, if my bid is accepted and the contract awarded to me.

INDEPENDENT PRICE DETERMINATION. The contract sum in this bid has been arrived at independently, without consultation, communication or agreement for the purpose of restricting competition.

DIVISION 0 – BIDDING & CONTRACT REQUIREMENTS
SECTION 03105 - BID FORM

PREVAILING WAGE. The contractor and each subcontractor shall pay not less than the general prevailing rate of hourly wages for work of a similar character in the locality in which the work is performed and not less than general prevailing rate of hourly wages for legal holidays and overtime work in the performance of work under this contract, as established by the Illinois Department of Labor, pursuant to an act of the General Assembly of the State of Illinois approved June 26, 1941 as amended according to Section 820 ILCS 130/1.

Pursuant to Section 820 ILCS 130/5, the contractor and each subcontractor shall keep an accurate record showing the names and occupation of all laborers, workers and mechanics employed by them, and also showing the actual hourly wages paid to each such individual, which record shall be open at all reasonable hours to inspection by the Owner, its officers and agents, and to agents of the Illinois Department of Labor.

The contractor and each subcontractor hereby agree, jointly and severally, to defend, indemnify and hold harmless the Owner from any and all claims, demands, liens or suits of any kind or nature whatsoever (including suits for injunctive relief) by the Illinois Department of Labor under the Illinois Prevailing Wage Act, Section 820 ILCS 130/1., or by any laborer, worker or mechanic employed by the contractor or the subcontractor who alleges that he has been paid for his services in a sum less than prevailing wage rates required by Illinois law. The Owner agrees to notify the contractor or subcontractor of the pendency of any such claim, demand, lien or suit.

DIVISION 0 – BIDDING & CONTRACT REQUIREMENTS
SECTION 03105 - BID FORM

By submitting a bid, each bidder agrees to waive any claim it has or may have against the Owner, the Architect, Engineer, Construction Manager and their respective employees, arising out of or in connection with the administration, evaluation, or recommendation of any bid; waiver of any requirements under the Bid Documents; or the Contract Document; acceptance or rejection of any bids; and award of the Contract.

Signature:

Respectfully submitted this _____ day _____, 2020

Type of Firm (Bidder to indicate)

_____ Individual

_____ Partnership

_____ Corporation

_____ Joint Venture

_____ Other

(Firm Name)

(Address)

(CORPORATE SEAL)

(Telephone Number) (FAX)

(E-mail Address)

(Bidder's Signature)

(Title)

Subscribed and sworn to me
this _____ day of _____, 2020

NOTE: All pages of this bid form must be returned with your proposal. Failure to do so shall disqualify your bid.

CERTIFICATE OF BIDDER ELIGIBILITY

720 ILCS 5/33E-11 REQUIRES THAT ALL CONTRACTORS BIDDING FOR PUBLIC AGENCIES IN THE State of Illinois certify that they are not barred from bidding on public contracts for bid rigging or bid rotation.

The following certification must be signed and submitted with bidder's bid proposal. FAILURE TO DO SO MAY RESULT IN DISQUALIFICATION OF THE BIDDER.

_____, as part of its bid for the _____ work for Community High School District 99, Downers Grove, Illinois, DuPage County, Illinois certified that said contractor is not barred from bidding on the aforementioned contract as a result of violation of either 720 ILCS 5/33E-3 or 720 ILCS 5/33-E4.

Firm: _____

By: _____
(Signature)

(Printed Name & Title)

SUBSCRIBED AND SWORN TO before me

This _____ day of _____, 2020

NOTARY PUBLIC

**CRIMINAL CODE CERTIFICATION
AS REQUIRED BY:
STATE OF ILLINOIS CRIMINAL CODE OF 2012, 720 ILCS 5/33E-11**

I, _____ the individual whose signature appears below on this bid/contract
for _____ hereby certify that the bidding
party/contracting party is not barred from bidding on the contract as a result of a violation of either Section 33E-3 or
Section 33E-4 of 720 ILCS 5/33E-3 or 5/33E-4 of the Illinois Compiled Statutes, as amended.

By: _____
Authorized Agent of Contractor (name and title)

SUBSCRIBED AND SWORN to before
me this ____ day _____, 20__.

Notary Public

EQUAL EMPLOYMENT OPPORTUNITY

Section I. This EQUAL EMPLOYMENT OPPORTUNITY CLAUSE is required by the Illinois Human Rights Act and the Rules and Regulations of the Illinois Department of Human Rights published at 44 Illinois Administrative Code Section 750, *et seq.*

Section II. In the event of the Contractor's noncompliance with any provision of this Equal Employment Opportunity Clause, the Illinois Human Rights Act, or the Rules and Regulations of the Department of Human Rights (hereinafter referred to as the Department) the Contractor may be declared ineligible for future contracts or subcontracts with the State of Illinois or any of its political subdivisions or municipal corporations, and this Contract may be canceled or voided in whole or in part, and other sanctions or penalties may be imposed or remedies involved as provided by statute or regulation.

During the performance of this Agreement, the Contractor agrees:

A. That it will not discriminate against any employee or applicant for employment because of race, color, religion, sex, sexual orientation, national origin or ancestry, citizenship status, age, physical or mental disability unrelated to ability, military status or an unfavorable discharge from military service; and further that it will examine all job classifications to determine if minority persons or women are underutilized and will take appropriate affirmative action to rectify any such underutilization.

B. That, if it hires additional employees in order to perform this Contract, or any portion hereof, it will determine the availability (in accordance with the Department's Rules and Regulations) of minorities and women in the area(s) from which it may reasonably recruit and it will hire for each job classification for which employees are hired in such a way that minorities and women are not underutilized.

C. That, in all solicitations or advertisements for employees placed by it or on its behalf, it will state that all applicants will be afforded equal opportunity without discrimination because of race, color, religion, sex, sexual orientation, marital status, national origin or ancestry, citizenship status, age, or physical or mental handicap unrelated to ability, military status or an unfavorable discharge from military service.

D. That it will send to each labor organization or representative of workers with which it has or is bound by a collective bargaining or other agreement or understanding, a notice advising such labor organization or representative of the Vendor's obligations under the Illinois Human Rights Act and Department's Rules and Regulations. If any labor organization or representative fails or refuses to cooperate with the Contractor in its efforts to comply with the Act and Rules and Regulations, the Contractor will promptly notify the Department and the contracting agency and will recruit employees from other sources when necessary to fulfill its obligations under the Contract.

E. That it will submit reports as required by the Department's Rules and Regulations, furnish all relevant information as may from time to time be requested by the Department or the contracting agency, and in all respects comply with the Illinois Human Rights Act and Department's Rules and Regulations.

F. That it will permit access to all relevant books, records, accounts and work sites by personnel of the contracting agency and Department for purposes of investigation to ascertain compliance with the Illinois Human Rights Act and Department's Rules and Regulations.

G. That it will include verbatim or by reference the provisions of this Equal Employment Opportunity Clause in every subcontract it awards under which any portion of this Contract obligations are undertaken or assumed, so that such provisions will be binding upon such subcontractor. In the same manner as the other provisions of this Agreement, the Contractor will be liable for compliance with applicable provisions of this clause by such subcontractors; and further it will promptly notify the contracting agency and the Department in the event any subcontractor fails or refuses to comply therewith. In addition, the Contractor will not utilize any subcontractor declared by the Illinois Human Rights Department to be ineligible for contracts or subcontracts with the State of Illinois or any of its political subdivisions or municipal corporations.

ACKNOWLEDGED AND AGREED TO:

By: _____
Authorized Agent of Contractor (name and title)

DATE: _____

SEXUAL HARASSMENT POLICY

_____, having submitted a bid for _____ (Name of Contractor)
_____ to Community High School District No. 00, hereby
certifies that said contractor has a written sexual harassment policy in place in full compliance with 775 ILCS 5/2-
105 (A) (4).

By: _____
Authorized Agent of Contractor (name and title)

SUBSCRIBED AND SWORN to before
me this _____ day _____, 20____.

Notary Public

TAX CERTIFICATION

I, _____, having been first duly sworn depose and state as follows:

I, _____, am the duly authorized agent for
_____ which has submitted a proposal to Community
High School District No. 99 for

_____ and I hereby certify that
_____ is not delinquent in the payment of any tax administered by the
Illinois Department of Revenue, or if it is:

a. it is contesting its liability for the tax or the amount of tax in accordance with procedures established by the appropriate Revenue Act; or

b. it has entered into an agreement with the Department of Revenue for payment of all taxes due and is currently in compliance with that agreement.

By: _____
Authorized Agent of Contractor (name and title)

SUBSCRIBED AND SWORN to before
me this _____ day _____, 20__.

Notary Public

SUBSTANCE ABUSE PREVENTION ON PUBLIC WORKS PROJECTS

The Contractor certifies that it has in place a written program that meets or exceeds the program requirements of the Substance Abuse Prevention on Public Works Projects Act (Public Act 95-0635), and will provide a copy thereof to Community High School District No. 99 prior to commencement of work on the Project.

By: _____
Authorized Agent of Contractor (name and title)

SUBSCRIBED AND SWORN to before
me this _____ day _____, 20__.

Notary Public

**CERTIFICATE REGARDING
EMPLOYMENT OF ILLINOIS WORKERS ON PUBLIC WORKS**

_____ agrees if at the time the Agreement is executed, or if during the term of the Agreement, there is excessive unemployment in Illinois as defined in the Employment of Illinois Workers on Public Works Act, 30- ILCS 570/0/01 et seq., as two consecutive months of unemployment exceeding 5%, then _____ agrees to employ Illinois laborers in accordance with the Employment of Illinois Workers on Public Works Act. An "Illinois laborer" is defined as any person who has resided in Illinois for at least thirty (30) days and intends to become or remain an Illinois resident.

Firm: _____

By: _____
(Signature)

(Printed Name & Title)

SUBSCRIBED AND SWORN TO before me

This _____ day of _____, 2020

NOTARY PUBLIC

PREVAILING WAGE AFFIDAVIT

AFFIDAVIT: "I (we) hereby certify and affirm that if awarded a contract with Community High School District 99, we will comply fully with the "Illinois Prevailing Wage Act (Ill. Rev. Stat., 1987 Ch. 48, Sections 398 s-1-12 as amended by Public Act 86-693 and 86-799 effected January 1, 1990, and any other amendments effective thereafter)". We further understand that current prevailing wage standards are included in the Supplementary General Conditions.

The following affidavit must be signed and submitted with bidder's bid proposal. FAILURE TO DO SO MAY RESULT IN DISQUALIFICATION OF THE BIDDER.

_____, as part of its bid for the _____ work for Community High School District 99, Downers Grove, Illinois, certifies that said contractor is not barred from bidding on the aforementioned contract as a result of a violation of the Illinois Prevailing Wage Act (Ill. Rev. Stat., 1987 Ch. 48, Sections 398 s-1-12 as amended by Public Act 86-693 and 86-799 effected January 1, 1990).

Firm: _____

By: _____
(Signature)

(Printed Name & Title)

SUBSCRIBED AND SWORN TO before me

This _____ day of _____, 2020

NOTARY PUBLIC

NON-COLLUSION AFFIDAVIT

AFFIDAVIT: "I (we) hereby certify and affirm that my (our) proposal was prepared independently for this project and that it contains no fees or amounts other than that for the legitimate execution of this work as specified and that it includes no understanding or agreements in restraint of trade."

The following affidavit must be signed and submitted with bidder's bid proposal.
FAILURE TO DO SO MAY RESULT IN DISQUALIFICATION OF THE BIDDER.

_____, as a part of its bid for the _____ work for
Community High School District 99, Downers Grove, Illinois, certifies that said Contractor is not barred from bidding
on the aforementioned contract as a result of a violation of the above Non-Collusion Affidavit.

Firm: _____

By: _____
(Signature)

(Printed Name & Title)

SUBSCRIBED AND SWORN TO before me

This _____ day of _____, 2020

NOTARY PUBLIC

Criminal Background Investigations

Contractor hereby represents, warrants and certified that no officer or director thereof has any knowledge that any employee thereof has been convicted of committing or attempting to commit "Criminal Code of 1961," 720 ILCS, Sections 5/11-6 (Indecent solicitation of a child), 5/11-9 (Public indecency), 5/11-14 (Prostitution), 5/11-15 (Soliciting for a prostitute), 5/11-15.1 (Soliciting for a juvenile prostitute), 5/11-19 (Pimping), 5/11-19.1 (Juvenile pimping), 5/11-19.2 (Exploitation of a child), 5/11-20 (Obscenity), 5/11-20.1 (Sexual assault), 5/12-14 (Aggravated criminal sexual assault), 5/12-15 (Criminal sexual abuse), and 5/120-16 (Aggravated criminal sexual abuse), and/or those offenses defined in the "Cannabis Control Act," 720 ILCS, 550/1 et seq. (except the "Illinois Controlled Substances Act," 720 ILCS 570/100 et seq. and/or any offense committed or attempted in any other state or against the laws of the United States, which if committed or attempted in this State, would have been punishable as one or more of the foregoing offenses.

Contractor further agrees that it shall not employ any person who have or may have direct, daily contact with the pupils of any school in the district, and for whom a criminal background investigation has not been conducted pursuant hereto, and further represents and agrees that all applicants for any such employment shall furnish with their applications the attached written "Authorization for Criminal Background Information" form authorizing the Board of Education to request a criminal background investigation of said applicant pursuant to Section 5/10-21.9 of the School Code of Illinois and to receive criminal history record information pursuant thereto to determine if the applicant has been convicted of committing or attempting to commit any of the criminal or drug offenses enumerated above. Contractor further agrees to submit with said authorization payment for any costs and expenses associated with the criminal background investigation.

Contractor further represents, warrants, and certifies that no applicant for employment with respect to whom the criminal investigation reveals any conviction for committing and/or attempting to commit any of the above enumerated offenses shall be employed thereby in any position that involves or may involve contact with the students of the school district.

This certification is executed on the date hereinafter indicated by the designated contractor by its duly authorized officer.

Firm: _____

By: _____
(Signature)

(Printed Name & Title)

Date: _____

Criminal Background Investigation

The undersigned hereby authorizes in Board of Education of Community High School District 99, Downers Grove, Illinois, to request a criminal background investigation from the Illinois State Police, pursuant to Section 5/10-21.9 of the School Code of Illinois, 105 ILCS 5/10-21.9 and to receive criminal history record information pursuant thereto.

By: _____
(Signature of Applicant of Employee)

(Printed or Typed Name of Applicant Employee)

Date: _____

BUSINESS CLASSIFICATION

a) Business Entity (check one)

Corporation (Publicly held)* Not-for-Profit* Government Agency/Public Institution*
 Corporation (Privately held) Partnership Sole Proprietor

* If checked, do not complete section III (b) and (c) below.

b) Business Ownership (check one) If minority or woman owned, attach copy of certification evidence.

Large Business: Male Owned Woman Owned
Small Business: Male Owned Woman Owned

BUSINESS DEFINITIONS

Small Business Concern - an independently owned and operated concern certified, or certifiable, as a small business by the Federal Small Business Administration (SBA). Standard Industrial Classification (SIC) codes may be found in the Federal Acquisition Regulations, Section 19.102 or in the Federal Procurement Regulations, Section 1-1.701.

Small Disadvantaged or Minority Business Concern - a small business concern which is at least fifty-one percent (51%) owned by one or more socially and economically disadvantaged individuals or in the case of any publicly owned business, at least fifty-one percent (51%) of the stock of which is owned by such individuals; and whose management and daily business operations are controlled by one or more of such individuals. Business owners who certify that they are members of named groups (Black Americans, Hispanic Americans, Native Americans, Asian-Pacific Americans) are considered socially and economically disadvantaged.

Woman-Owned Business - a business concern that is at least fifty-one percent (51%) owned by a woman or women who also control and operate it. "Control" in this context means exercising the power to make policy decisions. "Operate" in this context means being actively involved in the day-to-day management.

c) Race/Ethnicity of Ownership (check one) based on definitions below.

Black Asian/Pacific or Asian/Indian Caucasian
 Hispanic Native American (American Indians, Eskimos, Aleuts and native Hawaiians)

ETHNIC GROUP DEFINITIONS

Black Americans: United States citizens whose origins are in any of the Black racial groups of Africa.
Hispanic Americans: United States citizens whose origins are in Mexico, Puerto Rico, Cuba, Portugal, Central or Central America.
Native Americans: United States citizens whose origins are in any of the original peoples of North America, i.e., American Indians, Eskimos, Aleuts and native Hawaiians.
Asian Pacific/Asian Indian Americans: United States citizens whose origins are in Japan, China, Korea, Taiwan, Cambodia, Laos, Vietnam, the Philippines, Samoa, Guam, the U.S. Trust Territories of the Pacific Islands, the Northern Mariana Islands, India, Pakistan, or Bangladesh.

I certify that the business classification and ethnicity indicated above reflects the true and correct status of this business in accordance with current Federal Small Business Administration criteria. I agree to inform Community High School District 99 immediately in writing of any changes to the information contained herein, including changes in ownership, controlling interest or operations. I understand that falsely certifying this information may result in suspension from participation in Community High School District 99 – South High School MFP Project.

Name: _____ Title: _____
(Print or Type)

Signature: _____ Date: _____

END OF SECTION 00301

BID DATE: February 7th, 2020 at 1:00 p.m. (CST)
(as date/time stamped by District 99's Receptionist)

BID TO: Community High School District 99
Administrative Center
6301 Springside Avenue
Downers Grove, IL 60516

RECEIVED BY:

BID FROM: _____

BID FOR: ***Bid Group #9 Bid Package #107 Acoustical Ceiling Tiles & Acoustical Wall Panels
Phase C***

South High School
1436 Norfolk Street
Downers Grove, IL 60516

It is required to have one original and one copy of your bid form.

THE UNDERSIGNED:

Acknowledges receipt of:

Plans and specifications for the work indicated above.

Addenda: No. _____ dated _____
No. _____ dated _____
No. _____ dated _____
No. _____ dated _____

Having examined the site of the work, and having familiarized himself or herself with local conditions affecting the cost of the work and with all requirements of the bidding documents including Instructions to Bidders, drawings, specifications and duly issued addenda as prepared by the architect, Wight & Company, hereby agrees to perform all work and furnish all labor, material and equipment specifically required of him by the bidding documents and such additional work as may be included as related requirements in other divisions or sections of the specifications, exclusive of alternate bids.

Agrees:

To furnish and install the described material and/or services for stated lump sum price.

To hold this bid open until **90** calendar days after bid opening date.

DIVISION 0 – BIDDING & CONTRACT REQUIREMENTS
SECTION 03107 - BID FORM

To accept the provisions of the General Provisions (Project Manual Division 0 – Bidding & Contracting Requirements Section 00201) and disposition of bid security.

To enter into and execute a contract with the Owner, if awarded on the basis of this bid, and in connection therewith to:

1. Furnish all bonds and insurance required by the bidding documents.
2. Accomplish the work in accordance with the contract.
3. Complete the work within the contract time herein specified.

Completion Time:

The undersigned agrees to begin construction immediately, or as directed by the Construction Manager, upon notice of contract award and to perform the following components of the work in accordance with the Construction Manager's Construction. This schedule is bound in the Project Manual. See attached scope of work in section 0300.

SCOPE OF WORK:

The work in this agreement (without additional compensation) shall include, but shall not necessarily be limited to, all skilled labor, supervision, premium time, materials, tools, equipment, plant, supplies, samples, shop drawings, design/engineering drawings, layout, transportation, supervision, contributions, insurance, taxes (if applicable), compliance with all agencies (City / Village, County, State, Federal and/or any other jurisdictional agency, as may be required) and/or all services and facilities necessary and/or required for the performance of all Work shown, detailed, and/or implied by the following documents and as defined herein.

It is understood that this Trade Contractor shall perform the Work for a complete and operational system as indicated or implied in all Contract Documents. It is recognized and understood that the documents upon which the bid is based are at a conceptual phase and this Contractor who has certain skills and judgments based upon his knowledge of techniques, procedures, systems, general state of the art of his specialty is expected to include in the scope of work, all items required in order to carry out a complete and functional system whether or not shown or described in the contract documents. This contract will be awarded on the basis of such documents with the understanding that this contractor is to furnish and install all items required for the proper completion of this work without adjustment to this contract price. No extra payments shall be made of claims entertained as a result of such items, unless it can be clearly demonstrated to be added scope to the contract and beyond the original intent of the documents.

Contractor to provide all Trade Contract work referenced in:

1. Any sheet of this bid group package including (reference Division 0 – Bidding and Contract Requirements, Section 00200 – Notice to Bidders).
2. Specification 00300 Bid Packages Scope Document.

WORK BASE BID: For providing all work including all allowances as required for the completion of the construction of the base bid project as shown on the drawings and specifications and NOT including alternate bids and/or contractor's proposed alternates and substitutes.

BASE BID

TOTAL BASE BID AMOUNT SOUTH HIGH SCHOOL MASTER FACILITY PLAN

_____ Dollars (\$ _____)

1. This TRADE CONTRACTOR shall include an allowance of **\$70,000.00 in their base bid** to account for any unforeseen conditions. Contract amounts will be adjusted by change order for amounts greater or less than the allowance. Allowance to be utilized only at the direction of Construction Manager.

BONDS:

This TRADE CONTRACTOR will be required to provide a Performance and Payment Bond for their work in accordance with 00201 of the General Conditions.

Award Basis:

The project will be awarded based upon the attached Evaluation Criteria, Section 301a. Owner and Construction Manager alternate's may be considered to find the most qualified bidder if the result of combining the base bid and the selected alternate(s) is the most qualified bid, and is to the benefit of the owner.

Each of the following amounts for alternate construction includes the entire cost of such construction, except as otherwise noted. Acceptance of any or all of the alternates for inclusion in the contract is the sole prerogative of the owner.

All additional costs due to the alternates are included in the amount to be added to the base bid, so that no additional costs will be borne by the owner due to acceptance of alternates. This alternate price is not to be included in the base bid price.

Owner Requested Alternates:

Each of the following amounts for alternate construction includes the entire cost of such construction, except as otherwise noted. Acceptance of any or all of the alternates for inclusion in the contract is the sole prerogative of the owner.

All additional costs due to the alternates are included in the amount to be added to the base bid, so that no additional costs will be borne by the owner due to acceptance of alternates.

Proposed Alternates: (Contractors Proposed Alternates)

Item Specified	Proposed Alternate	Change in Bid Price
1. _____	_____	_____
2. _____	_____	_____
3. _____	_____	_____

Owner Requested Unit Prices/Allowances (as applicable to this Trade Contractor's scope of work) (additive or deductive).

This trade contractor includes _____ dumpsters for all refuse caused by this trade contractor's work

in the amount of _____ Dollars (\$ _____) Note: trade contractors are to include in their bid form submittal the quantity of dumpsters required to complete their work and the cost associated with same. Dumpster costs will be subtracted by change order. Dumpsters will be procured and managed by Construction Manager. Note: Dumpster use in excess of that proposed by this Trade Contractor will be adjusted by back charge.

Owner Requested Scheduling Information:

Note: The work of this Trade Contractor is to be completed in accordance with the overall project schedule as

identified elsewhere in this project manual and/or as subsequently directed by Construction Manager. This Trade Contractor shall submit a proposed submittals list/schedule/material log within five (5) calendar days of Notice To Proceed.

1. Shop drawings / Submittal for this trade contractor will be submitted within 10 calendar days of receipt of notice to proceed.

Bid Acceptance:

If written notice of the acceptance of this bid is mailed, telegraphed or delivered to the undersigned within the time noted herein, after the date of opening of bids or at any time thereafter before this bid is withdrawn, the undersigned agrees that he will execute a construction contract in accordance with the bids as accepted.

The Owner reserves the right to award the contract to its best interests, review and accept any and all value engineering alternatives, negotiate with the lowest responsible bidder, to reject any or all bids, to waive any informalities in bidding and to hold all bids for the bid guarantee period. The Owner reserves the right to award separate contracts for any of the items of work bid herein.

Bid Deposit:

The undersigned furnishes herewith, as required in the Instructions to Bidders, a bid deposit in the amount of ten percent (10%) of the amount bid in the form of Cashier's Check, or Certified Check, made payable to the Owner or Bid Bond, naming the Owner as obligee. (Bidder to check form of deposit furnished.)

It is understood and agreed that should the undersigned fail to enter into a contract with the Owner or furnish acceptable contract security within the time and in the manner herein provided, the bid deposit shall be retained by the Owner as liquidated damages and not as a forfeiture. As it is impossible to determine precisely an exact amount of damages the Owner will sustain, it is agreed that the bid deposit is a fair and equitable estimate of such damages.

REPRESENTATIONS AND CERTIFICATIONS:

The bidder makes the following representations and certifications as part of his bid on the project herein identified in the Bid Form. In the case of a joint venture bid, each party represents and certifies as to his own organization.

AVAILABILITY. The number and amount of contracts and awards pending which I am and/or will be obligated to perform, now and during the course of the project, will not interfere with or hinder the timely prosecution of my work.

SURETY. I have notified a Surety Company that I am submitting a bid for work to be performed on the project. The Surety Company has agreed to issue a performance and labor and material payment bond for my work, if my bid is accepted and the contract awarded to me.

INDEPENDENT PRICE DETERMINATION. The contract sum in this bid has been arrived at independently, without consultation, communication or agreement for the purpose of restricting competition.

PREVAILING WAGE. The contractor and each subcontractor shall pay not less than the general prevailing rate of hourly wages for work of a similar character in the locality in which the work is performed and not less than general prevailing rate of hourly wages for legal holidays and overtime work in the performance of work under this contract, as established by the Illinois Department of Labor, pursuant to an act of the General Assembly of the State of Illinois approved June 26, 1941 as amended according to Section 820 ILCS 130/1.

Pursuant to Section 820 ILCS 130/5, the contractor and each subcontractor shall keep an accurate record showing the names and occupation of all laborers, workers and mechanics employed by them, and also showing the actual hourly wages paid to each such individual, which record shall be open at all reasonable hours to inspection by the Owner, its officers and agents, and to agents of the Illinois Department of Labor.

DIVISION 0 – BIDDING & CONTRACT REQUIREMENTS
SECTION 03107 - BID FORM

The contractor and each subcontractor hereby agree, jointly and severally, to defend, indemnify and hold harmless the Owner from any and all claims, demands, liens or suits of any kind or nature whatsoever (including suits for injunctive relief) by the Illinois Department of Labor under the Illinois Prevailing Wage Act, Section 820 ILCS 130/1., or by any laborer, worker or mechanic employed by the contractor or the subcontractor who alleges that he has been paid for his services in a sum less than prevailing wage rates required by Illinois law. The Owner agrees to notify the contractor or subcontractor of the pendency of any such claim, demand, lien or suit.

DIVISION 0 – BIDDING & CONTRACT REQUIREMENTS
SECTION 03107 - BID FORM

By submitting a bid, each bidder agrees to waive any claim it has or may have against the Owner, the Architect, Engineer, Construction Manager and their respective employees, arising out of or in connection with the administration, evaluation, or recommendation of any bid; waiver of any requirements under the Bid Documents; or the Contract Document; acceptance or rejection of any bids; and award of the Contract.

Signature:

Respectfully submitted this _____ day _____, 2020

Type of Firm (Bidder to indicate)

_____ Individual

_____ Partnership

_____ Corporation

_____ Joint Venture

_____ Other

(Firm Name)

(Address)

(CORPORATE SEAL)

(Telephone Number) (FAX)

(E-mail Address)

(Bidder's Signature)

(Title)

Subscribed and sworn to me
this _____ day of _____, 2020

NOTE: All pages of this bid form must be returned with your proposal. Failure to do so shall disqualify your bid.

CERTIFICATE OF BIDDER ELIGIBILITY

720 ILCS 5/33E-11 REQUIRES THAT ALL CONTRACTORS BIDDING FOR PUBLIC AGENCIES IN THE State of Illinois certify that they are not barred from bidding on public contracts for bid rigging or bid rotation.

The following certification must be signed and submitted with bidder's bid proposal. FAILURE TO DO SO MAY RESULT IN DISQUALIFICATION OF THE BIDDER.

_____, as part of its bid for the _____ work for Community High School District 99, Downers Grove, Illinois, DuPage County, Illinois certified that said contractor is not barred from bidding on the aforementioned contract as a result of violation of either 720 ILCS 5/33E-3 or 720 ILCS 5/33-E4.

Firm: _____

By: _____
(Signature)

(Printed Name & Title)

SUBSCRIBED AND SWORN TO before me

This _____ day of _____, 2020

NOTARY PUBLIC

**CRIMINAL CODE CERTIFICATION
AS REQUIRED BY:
STATE OF ILLINOIS CRIMINAL CODE OF 2012, 720 ILCS 5/33E-11**

I, _____ the individual whose signature appears below on this bid/contract
for _____ hereby certify that the bidding
party/contracting party is not barred from bidding on the contract as a result of a violation of either Section 33E-3 or
Section 33E-4 of 720 ILCS 5/33E-3 or 5/33E-4 of the Illinois Compiled Statutes, as amended.

By: _____
Authorized Agent of Contractor (name and title)

SUBSCRIBED AND SWORN to before
me this ____ day _____, 20__.

Notary Public

EQUAL EMPLOYMENT OPPORTUNITY

Section I. This EQUAL EMPLOYMENT OPPORTUNITY CLAUSE is required by the Illinois Human Rights Act and the Rules and Regulations of the Illinois Department of Human Rights published at 44 Illinois Administrative Code Section 750, *et seq.*

Section II. In the event of the Contractor's noncompliance with any provision of this Equal Employment Opportunity Clause, the Illinois Human Rights Act, or the Rules and Regulations of the Department of Human Rights (hereinafter referred to as the Department) the Contractor may be declared ineligible for future contracts or subcontracts with the State of Illinois or any of its political subdivisions or municipal corporations, and this Contract may be canceled or voided in whole or in part, and other sanctions or penalties may be imposed or remedies involved as provided by statute or regulation.

During the performance of this Agreement, the Contractor agrees:

A. That it will not discriminate against any employee or applicant for employment because of race, color, religion, sex, sexual orientation, national origin or ancestry, citizenship status, age, physical or mental disability unrelated to ability, military status or an unfavorable discharge from military service; and further that it will examine all job classifications to determine if minority persons or women are underutilized and will take appropriate affirmative action to rectify any such underutilization.

B. That, if it hires additional employees in order to perform this Contract, or any portion hereof, it will determine the availability (in accordance with the Department's Rules and Regulations) of minorities and women in the area(s) from which it may reasonably recruit and it will hire for each job classification for which employees are hired in such a way that minorities and women are not underutilized.

C. That, in all solicitations or advertisements for employees placed by it or on its behalf, it will state that all applicants will be afforded equal opportunity without discrimination because of race, color, religion, sex, sexual orientation, marital status, national origin or ancestry, citizenship status, age, or physical or mental handicap unrelated to ability, military status or an unfavorable discharge from military service.

D. That it will send to each labor organization or representative of workers with which it has or is bound by a collective bargaining or other agreement or understanding, a notice advising such labor organization or representative of the Vendor's obligations under the Illinois Human Rights Act and Department's Rules and Regulations. If any labor organization or representative fails or refuses to cooperate with the Contractor in its efforts to comply with the Act and Rules and Regulations, the Contractor will promptly notify the Department and the contracting agency and will recruit employees from other sources when necessary to fulfill its obligations under the Contract.

E. That it will submit reports as required by the Department's Rules and Regulations, furnish all relevant information as may from time to time be requested by the Department or the contracting agency, and in all respects comply with the Illinois Human Rights Act and Department's Rules and Regulations.

F. That it will permit access to all relevant books, records, accounts and work sites by personnel of the contracting agency and Department for purposes of investigation to ascertain compliance with the Illinois Human Rights Act and Department's Rules and Regulations.

G. That it will include verbatim or by reference the provisions of this Equal Employment Opportunity Clause in every subcontract it awards under which any portion of this Contract obligations are undertaken or assumed, so that such provisions will be binding upon such subcontractor. In the same manner as the other provisions of this Agreement, the Contractor will be liable for compliance with applicable provisions of this clause by such subcontractors; and further it will promptly notify the contracting agency and the Department in the event any subcontractor fails or refuses to comply therewith. In addition, the Contractor will not utilize any subcontractor declared by the Illinois Human Rights Department to be ineligible for contracts or subcontracts with the State of Illinois or any of its political subdivisions or municipal corporations.

ACKNOWLEDGED AND AGREED TO:

By: _____
Authorized Agent of Contractor (name and title)

DATE: _____

SEXUAL HARASSMENT POLICY

_____, having submitted a bid for _____ (Name of Contractor)
_____ to Community High School District No. 00, hereby
certifies that said contractor has a written sexual harassment policy in place in full compliance with 775 ILCS 5/2-
105 (A) (4).

By: _____
Authorized Agent of Contractor (name and title)

SUBSCRIBED AND SWORN to before
me this _____ day _____, 20____.

Notary Public

TAX CERTIFICATION

I, _____, having been first duly sworn depose and state as follows:

I, _____, am the duly authorized agent for
_____ which has submitted a proposal to Community
High School District No. 99 for

_____ and I hereby certify that
_____ is not delinquent in the payment of any tax administered by the
Illinois Department of Revenue, or if it is:

a. it is contesting its liability for the tax or the amount of tax in accordance with procedures established by the appropriate Revenue Act; or

b. it has entered into an agreement with the Department of Revenue for payment of all taxes due and is currently in compliance with that agreement.

By: _____
Authorized Agent of Contractor (name and title)

SUBSCRIBED AND SWORN to before
me this _____ day _____, 20__.

Notary Public

SUBSTANCE ABUSE PREVENTION ON PUBLIC WORKS PROJECTS

The Contractor certifies that it has in place a written program that meets or exceeds the program requirements of the Substance Abuse Prevention on Public Works Projects Act (Public Act 95-0635), and will provide a copy thereof to Community High School District No. 99 prior to commencement of work on the Project.

By: _____
Authorized Agent of Contractor (name and title)

SUBSCRIBED AND SWORN to before
me this ____ day _____, 20__.

Notary Public

**CERTIFICATE REGARDING
EMPLOYMENT OF ILLINOIS WORKERS ON PUBLIC WORKS**

_____ agrees if at the time the Agreement is executed, or if during the term of the Agreement, there is excessive unemployment in Illinois as defined in the Employment of Illinois Workers on Public Works Act, 30- ILCS 570/0/01 et seq., as two consecutive months of unemployment exceeding 5%, then _____ agrees to employ Illinois laborers in accordance with the Employment of Illinois Workers on Public Works Act. An "Illinois laborer" is defined as any person who has resided in Illinois for at least thirty (30) days and intends to become or remain an Illinois resident.

Firm: _____

By: _____
(Signature)

(Printed Name & Title)

SUBSCRIBED AND SWORN TO before me

This _____ day of _____, 2020

NOTARY PUBLIC

PREVAILING WAGE AFFIDAVIT

AFFIDAVIT: "I (we) hereby certify and affirm that if awarded a contract with Community High School District 99, we will comply fully with the "Illinois Prevailing Wage Act (Ill. Rev. Stat., 1987 Ch. 48, Sections 398 s-1-12 as amended by Public Act 86-693 and 86-799 effected January 1, 1990, and any other amendments effective thereafter)". We further understand that current prevailing wage standards are included in the Supplementary General Conditions.

The following affidavit must be signed and submitted with bidder's bid proposal. FAILURE TO DO SO MAY RESULT IN DISQUALIFICATION OF THE BIDDER.

_____, as part of its bid for the _____ work for Community High School District 99, Downers Grove, Illinois, certifies that said contractor is not barred from bidding on the aforementioned contract as a result of a violation of the Illinois Prevailing Wage Act (Ill. Rev. Stat., 1987 Ch. 48, Sections 398 s-1-12 as amended by Public Act 86-693 and 86-799 effected January 1, 1990).

Firm: _____

By: _____
(Signature)

(Printed Name & Title)

SUBSCRIBED AND SWORN TO before me

This _____ day of _____, 2020

NOTARY PUBLIC

NON-COLLUSION AFFIDAVIT

AFFIDAVIT: "I (we) hereby certify and affirm that my (our) proposal was prepared independently for this project and that it contains no fees or amounts other than that for the legitimate execution of this work as specified and that it includes no understanding or agreements in restraint of trade."

The following affidavit must be signed and submitted with bidder's bid proposal.
FAILURE TO DO SO MAY RESULT IN DISQUALIFICATION OF THE BIDDER.

_____, as a part of its bid for the _____ work for
Community High School District 99, Downers Grove, Illinois, certifies that said Contractor is not barred from bidding
on the aforementioned contract as a result of a violation of the above Non-Collusion Affidavit.

Firm: _____

By: _____
(Signature)

(Printed Name & Title)

SUBSCRIBED AND SWORN TO before me

This _____ day of _____, 2020

NOTARY PUBLIC

Criminal Background Investigations

Contractor hereby represents, warrants and certified that no officer or director thereof has any knowledge that any employee thereof has been convicted of committing or attempting to commit "Criminal Code of 1961," 720 ILCS, Sections 5/11-6 (Indecent solicitation of a child), 5/11-9 (Public indecency), 5/11-14 (Prostitution), 5/11-15 (Soliciting for a prostitute), 5/11-15.1 (Soliciting for a juvenile prostitute), 5/11-19 (Pimping), 5/11-19.1 (Juvenile pimping), 5/11-19.2 (Exploitation of a child), 5/11-20 (Obscenity), 5/11-20.1 (Sexual assault), 5/12-14 (Aggravated criminal sexual assault), 5/12-15 (Criminal sexual abuse), and 5/120-16 (Aggravated criminal sexual abuse), and/or those offenses defined in the "Cannabis Control Act," 720 ILCS, 550/1 et seq. (except the "Illinois Controlled Substances Act," 720 ILCS 570/100 et seq. and/or any offense committed or attempted in any other state or against the laws of the United States, which if committed or attempted in this State, would have been punishable as one or more of the foregoing offenses.

Contractor further agrees that it shall not employ any person who have or may have direct, daily contact with the pupils of any school in the district, and for whom a criminal background investigation has not been conducted pursuant hereto, and further represents and agrees that all applicants for any such employment shall furnish with their applications the attached written "Authorization for Criminal Background Information" form authorizing the Board of Education to request a criminal background investigation of said applicant pursuant to Section 5/10-21.9 of the School Code of Illinois and to receive criminal history record information pursuant thereto to determine if the applicant has been convicted of committing or attempting to commit any of the criminal or drug offenses enumerated above. Contractor further agrees to submit with said authorization payment for any costs and expenses associated with the criminal background investigation.

Contractor further represents, warrants, and certifies that no applicant for employment with respect to whom the criminal investigation reveals any conviction for committing and/or attempting to commit any of the above enumerated offenses shall be employed thereby in any position that involves or may involve contact with the students of the school district.

This certification is executed on the date hereinafter indicated by the designated contractor by its duly authorized officer.

Firm: _____

By: _____
(Signature)

(Printed Name & Title)

Date: _____

Criminal Background Investigation

The undersigned hereby authorizes in Board of Education of Community High School District 99, Downers Grove, Illinois, to request a criminal background investigation from the Illinois State Police, pursuant to Section 5/10-21.9 of the School Code of Illinois, 105 ILCS 5/10-21.9 and to receive criminal history record information pursuant thereto.

By: _____
(Signature of Applicant of Employee)

(Printed or Typed Name of Applicant Employee)

Date: _____

BUSINESS CLASSIFICATION

a) Business Entity (check one)

Corporation (Publicly held)* Not-for-Profit* Government Agency/Public Institution*
 Corporation (Privately held) Partnership Sole Proprietor

* If checked, do not complete section III (b) and (c) below.

b) Business Ownership (check one) If minority or woman owned, attach copy of certification evidence.

Large Business: Male Owned Woman Owned
Small Business: Male Owned Woman Owned

BUSINESS DEFINITIONS

Small Business Concern - an independently owned and operated concern certified, or certifiable, as a small business by the Federal Small Business Administration (SBA). Standard Industrial Classification (SIC) codes may be found in the Federal Acquisition Regulations, Section 19.102 or in the Federal Procurement Regulations, Section 1-1.701.

Small Disadvantaged or Minority Business Concern - a small business concern which is at least fifty-one percent (51%) owned by one or more socially and economically disadvantaged individuals or in the case of any publicly owned business, at least fifty-one percent (51%) of the stock of which is owned by such individuals; and whose management and daily business operations are controlled by one or more of such individuals. Business owners who certify that they are members of named groups (Black Americans, Hispanic Americans, Native Americans, Asian-Pacific Americans) are considered socially and economically disadvantaged.

Woman-Owned Business - a business concern that is at least fifty-one percent (51%) owned by a woman or women who also control and operate it. "Control" in this context means exercising the power to make policy decisions. "Operate" in this context means being actively involved in the day-to-day management.

c) Race/Ethnicity of Ownership (check one) based on definitions below.

Black Asian/Pacific or Asian/Indian Caucasian
 Hispanic Native American (American Indians, Eskimos, Aleuts and native Hawaiians)

ETHNIC GROUP DEFINITIONS

Black Americans: United States citizens whose origins are in any of the Black racial groups of Africa.
Hispanic Americans: United States citizens whose origins are in Mexico, Puerto Rico, Cuba, Portugal, Central or Central America.
Native Americans: United States citizens whose origins are in any of the original peoples of North America, i.e., American Indians, Eskimos, Aleuts and native Hawaiians.
Asian Pacific/Asian Indian Americans: United States citizens whose origins are in Japan, China, Korea, Taiwan, Cambodia, Laos, Vietnam, the Philippines, Samoa, Guam, the U.S. Trust Territories of the Pacific Islands, the Northern Mariana Islands, India, Pakistan, or Bangladesh.

I certify that the business classification and ethnicity indicated above reflects the true and correct status of this business in accordance with current Federal Small Business Administration criteria. I agree to inform Community High School District 99 immediately in writing of any changes to the information contained herein, including changes in ownership, controlling interest or operations. I understand that falsely certifying this information may result in suspension from participation in Community High School District 99 – South High School MFP Project.

Name: _____ Title: _____
(Print or Type)

Signature: _____ Date: _____

END OF SECTION 00301

BID DATE: February 7th, 2020 at 1:00 p.m. (CST)
(as date/time stamped by District 99's Receptionist)

BID TO: Community High School District 99
Administrative Center
6301 Springside Avenue
Downers Grove, IL 60516

RECEIVED BY:

BID FROM: _____

BID FOR: ***Bid Group #9 Bid Package #109 Theatre Shells
Phase C***

South High School
1436 Norfolk Street
Downers Grove, IL 60516

It is required to have one original and one copy of your bid form.

THE UNDERSIGNED:

Acknowledges receipt of:

Plans and specifications for the work indicated above.

Addenda: No. _____ dated _____
No. _____ dated _____
No. _____ dated _____
No. _____ dated _____

Having examined the site of the work, and having familiarized himself or herself with local conditions affecting the cost of the work and with all requirements of the bidding documents including Instructions to Bidders, drawings, specifications and duly issued addenda as prepared by the architect, Wight & Company, hereby agrees to perform all work and furnish all labor, material and equipment specifically required of him by the bidding documents and such additional work as may be included as related requirements in other divisions or sections of the specifications, exclusive of alternate bids.

Agrees:

To furnish and install the described material and/or services for stated lump sum price.

To hold this bid open until **90** calendar days after bid opening date.

DIVISION 0 – BIDDING & CONTRACT REQUIREMENTS
SECTION 03109 - BID FORM

To accept the provisions of the General Provisions (Project Manual Division 0 – Bidding & Contracting Requirements Section 00201) and disposition of bid security.

To enter into and execute a contract with the Owner, if awarded on the basis of this bid, and in connection therewith to:

1. Furnish all bonds and insurance required by the bidding documents.
2. Accomplish the work in accordance with the contract.
3. Complete the work within the contract time herein specified.

Completion Time:

The undersigned agrees to begin construction immediately, or as directed by the Construction Manager, upon notice of contract award and to perform the following components of the work in accordance with the Construction Manager's Construction. This schedule is bound in the Project Manual. See attached scope of work in section 0300.

SCOPE OF WORK:

The work in this agreement (without additional compensation) shall include, but shall not necessarily be limited to, all skilled labor, supervision, premium time, materials, tools, equipment, plant, supplies, samples, shop drawings, design/engineering drawings, layout, transportation, supervision, contributions, insurance, taxes (if applicable), compliance with all agencies (City / Village, County, State, Federal and/or any other jurisdictional agency, as may be required) and/or all services and facilities necessary and/or required for the performance of all Work shown, detailed, and/or implied by the following documents and as defined herein.

It is understood that this Trade Contractor shall perform the Work for a complete and operational system as indicated or implied in all Contract Documents. It is recognized and understood that the documents upon which the bid is based are at a conceptual phase and this Contractor who has certain skills and judgments based upon his knowledge of techniques, procedures, systems, general state of the art of his specialty is expected to include in the scope of work, all items required in order to carry out a complete and functional system whether or not shown or described in the contract documents. This contract will be awarded on the basis of such documents with the understanding that this contractor is to furnish and install all items required for the proper completion of this work without adjustment to this contract price. No extra payments shall be made of claims entertained as a result of such items, unless it can be clearly demonstrated to be added scope to the contract and beyond the original intent of the documents.

Contractor to provide all Trade Contract work referenced in:

1. Any sheet of this bid group package including (reference Division 0 – Bidding and Contract Requirements, Section 00200 – Notice to Bidders).
2. Specification 00300 Bid Packages Scope Document.

WORK BASE BID: For providing all work including all allowances as required for the completion of the construction of the base bid project as shown on the drawings and specifications and NOT including alternate bids and/or contractor's proposed alternates and substitutes.

BASE BID

TOTAL BASE BID AMOUNT SOUTH HIGH SCHOOL MASTER FACILITY PLAN

_____ Dollars (\$ _____)

1. This TRADE CONTRACTOR shall include an allowance of **\$5,000.00 in their base bid** to account for any unforeseen conditions. Contract amounts will be adjusted by change order for amounts greater or less than the allowance. Allowance to be utilized only at the direction of Construction Manager.

BONDS:

This TRADE CONTRACTOR will be required to provide a Performance and Payment Bond for their work in accordance with 00201 of the General Conditions.

Award Basis:

The project will be awarded based upon the attached Evaluation Criteria, Section 301a. Owner and Construction Manager alternate's may be considered to find the most qualified bidder if the result of combining the base bid and the selected alternate(s) is the most qualified bid, and is to the benefit of the owner.

Each of the following amounts for alternate construction includes the entire cost of such construction, except as otherwise noted. Acceptance of any or all of the alternates for inclusion in the contract is the sole prerogative of the owner.

All additional costs due to the alternates are included in the amount to be added to the base bid, so that no additional costs will be borne by the owner due to acceptance of alternates. This alternate price is not to be included in the base bid price.

Owner Requested Alternates:

Each of the following amounts for alternate construction includes the entire cost of such construction, except as otherwise noted. Acceptance of any or all of the alternates for inclusion in the contract is the sole prerogative of the owner.

All additional costs due to the alternates are included in the amount to be added to the base bid, so that no additional costs will be borne by the owner due to acceptance of alternates.

Proposed Alternates: (Contractors Proposed Alternates)

	Item Specified	Proposed Alternate	Change in Bid Price
1.	_____	_____	_____
2.	_____	_____	_____
3.	_____	_____	_____

Owner Requested Unit Prices/Allowances (as applicable to this Trade Contractor's scope of work) (additive or deductive).

This trade contractor includes _____ dumpsters for all refuse caused by this trade contractor's work in the amount of _____ Dollars (\$_____) Note: trade contractors are to include in their bid form submittal the quantity of dumpsters required to complete their work and the cost associated with same. Dumpster costs will be subtracted by change order. Dumpsters will be procured and managed by Construction Manager. Note: Dumpster use in excess of that proposed by this Trade Contractor will be adjusted by back charge.

Owner Requested Scheduling Information:

Note: The work of this Trade Contractor is to be completed in accordance with the overall project schedule as identified elsewhere in this project manual and/or as subsequently directed by Construction Manager. This Trade

Contractor shall submit a proposed submittals list/schedule/material log within five (5) calendar days of Notice To Proceed.

1. Shop drawings / Submittal for this trade contractor will be submitted within 10 calendar days of receipt of notice to proceed.

Bid Acceptance:

If written notice of the acceptance of this bid is mailed, telegraphed or delivered to the undersigned within the time noted herein, after the date of opening of bids or at any time thereafter before this bid is withdrawn, the undersigned agrees that he will execute a construction contract in accordance with the bids as accepted.

The Owner reserves the right to award the contract to its best interests, review and accept any and all value engineering alternatives, negotiate with the lowest responsible bidder, to reject any or all bids, to waive any informalities in bidding and to hold all bids for the bid guarantee period. The Owner reserves the right to award separate contracts for any of the items of work bid herein.

Bid Deposit:

The undersigned furnishes herewith, as required in the Instructions to Bidders, a bid deposit in the amount of ten percent (10%) of the amount bid in the form of Cashier's Check, or Certified Check, made payable to the Owner or Bid Bond, naming the Owner as obligee. (Bidder to check form of deposit furnished.)

It is understood and agreed that should the undersigned fail to enter into a contract with the Owner or furnish acceptable contract security within the time and in the manner herein provided, the bid deposit shall be retained by the Owner as liquidated damages and not as a forfeiture. As it is impossible to determine precisely an exact amount of damages the Owner will sustain, it is agreed that the bid deposit is a fair and equitable estimate of such damages.

REPRESENTATIONS AND CERTIFICATIONS:

The bidder makes the following representations and certifications as part of his bid on the project herein identified in the Bid Form. In the case of a joint venture bid, each party represents and certifies as to his own organization.

AVAILABILITY. The number and amount of contracts and awards pending which I am and/or will be obligated to perform, now and during the course of the project, will not interfere with or hinder the timely prosecution of my work.

SURETY. I have notified a Surety Company that I am submitting a bid for work to be performed on the project. The Surety Company has agreed to issue a performance and labor and material payment bond for my work, if my bid is accepted and the contract awarded to me.

INDEPENDENT PRICE DETERMINATION. The contract sum in this bid has been arrived at independently, without consultation, communication or agreement for the purpose of restricting competition.

PREVAILING WAGE. The contractor and each subcontractor shall pay not less than the general prevailing rate of hourly wages for work of a similar character in the locality in which the work is performed and not less than general prevailing rate of hourly wages for legal holidays and overtime work in the performance of work under this contract, as established by the Illinois Department of Labor, pursuant to an act of the General Assembly of the State of Illinois approved June 26, 1941 as amended according to Section 820 ILCS 130/1.

Pursuant to Section 820 ILCS 130/5, the contractor and each subcontractor shall keep an accurate record showing the names and occupation of all laborers, workers and mechanics employed by them, and also showing the actual hourly wages paid to each such individual, which record shall be open at all reasonable hours to inspection by the Owner, its officers and agents, and to agents of the Illinois Department of Labor.

DIVISION 0 – BIDDING & CONTRACT REQUIREMENTS
SECTION 03109 - BID FORM

The contractor and each subcontractor hereby agree, jointly and severally, to defend, indemnify and hold harmless the Owner from any and all claims, demands, liens or suits of any kind or nature whatsoever (including suits for injunctive relief) by the Illinois Department of Labor under the Illinois Prevailing Wage Act, Section 820 ILCS 130/1., or by any laborer, worker or mechanic employed by the contractor or the subcontractor who alleges that he has been paid for his services in a sum less than prevailing wage rates required by Illinois law. The Owner agrees to notify the contractor or subcontractor of the pendency of any such claim, demand, lien or suit.

DIVISION 0 – BIDDING & CONTRACT REQUIREMENTS
SECTION 03109 - BID FORM

By submitting a bid, each bidder agrees to waive any claim it has or may have against the Owner, the Architect, Engineer, Construction Manager and their respective employees, arising out of or in connection with the administration, evaluation, or recommendation of any bid; waiver of any requirements under the Bid Documents; or the Contract Document; acceptance or rejection of any bids; and award of the Contract.

Signature:

Respectfully submitted this _____ day _____, 2020

Type of Firm (Bidder to indicate)

_____ Individual

_____ Partnership

_____ Corporation

_____ Joint Venture

_____ Other

(CORPORATE SEAL)

(Firm Name)

(Address)

(Telephone Number) (FAX)

(E-mail Address)

(Bidder's Signature)

(Title)

Subscribed and sworn to me
this _____ day of _____, 2020

NOTE: All pages of this bid form must be returned with your proposal. Failure to do so shall disqualify your bid.

CERTIFICATE OF BIDDER ELIGIBILITY

720 ILCS 5/33E-11 REQUIRES THAT ALL CONTRACTORS BIDDING FOR PUBLIC AGENCIES IN THE State of Illinois certify that they are not barred from bidding on public contracts for bid rigging or bid rotation.

The following certification must be signed and submitted with bidder's bid proposal. FAILURE TO DO SO MAY RESULT IN DISQUALIFICATION OF THE BIDDER.

_____, as part of its bid for the _____ work for Community High School District 99, Downers Grove, Illinois, DuPage County, Illinois certified that said contractor is not barred from bidding on the aforementioned contract as a result of violation of either 720 ILCS 5/33E-3 or 720 ILCS 5/33-E4.

Firm: _____

By: _____
(Signature)

(Printed Name & Title)

SUBSCRIBED AND SWORN TO before me

This _____ day of _____, 2020

NOTARY PUBLIC

**CRIMINAL CODE CERTIFICATION
AS REQUIRED BY:
STATE OF ILLINOIS CRIMINAL CODE OF 2012, 720 ILCS 5/33E-11**

I, _____ the individual whose signature appears below on this bid/contract
for _____ hereby certify that the bidding
party/contracting party is not barred from bidding on the contract as a result of a violation of either Section 33E-3 or
Section 33E-4 of 720 ILCS 5/33E-3 or 5/33E-4 of the Illinois Compiled Statutes, as amended.

By: _____
Authorized Agent of Contractor (name and title)

SUBSCRIBED AND SWORN to before
me this ____ day _____, 20__.

Notary Public

EQUAL EMPLOYMENT OPPORTUNITY

Section I. This EQUAL EMPLOYMENT OPPORTUNITY CLAUSE is required by the Illinois Human Rights Act and the Rules and Regulations of the Illinois Department of Human Rights published at 44 Illinois Administrative Code Section 750, *et seq.*

Section II. In the event of the Contractor's noncompliance with any provision of this Equal Employment Opportunity Clause, the Illinois Human Rights Act, or the Rules and Regulations of the Department of Human Rights (hereinafter referred to as the Department) the Contractor may be declared ineligible for future contracts or subcontracts with the State of Illinois or any of its political subdivisions or municipal corporations, and this Contract may be canceled or voided in whole or in part, and other sanctions or penalties may be imposed or remedies involved as provided by statute or regulation.

During the performance of this Agreement, the Contractor agrees:

A. That it will not discriminate against any employee or applicant for employment because of race, color, religion, sex, sexual orientation, national origin or ancestry, citizenship status, age, physical or mental disability unrelated to ability, military status or an unfavorable discharge from military service; and further that it will examine all job classifications to determine if minority persons or women are underutilized and will take appropriate affirmative action to rectify any such underutilization.

B. That, if it hires additional employees in order to perform this Contract, or any portion hereof, it will determine the availability (in accordance with the Department's Rules and Regulations) of minorities and women in the area(s) from which it may reasonably recruit and it will hire for each job classification for which employees are hired in such a way that minorities and women are not underutilized.

C. That, in all solicitations or advertisements for employees placed by it or on its behalf, it will state that all applicants will be afforded equal opportunity without discrimination because of race, color, religion, sex, sexual orientation, marital status, national origin or ancestry, citizenship status, age, or physical or mental handicap unrelated to ability, military status or an unfavorable discharge from military service.

D. That it will send to each labor organization or representative of workers with which it has or is bound by a collective bargaining or other agreement or understanding, a notice advising such labor organization or representative of the Vendor's obligations under the Illinois Human Rights Act and Department's Rules and Regulations. If any labor organization or representative fails or refuses to cooperate with the Contractor in its efforts to comply with the Act and Rules and Regulations, the Contractor will promptly notify the Department and the contracting agency and will recruit employees from other sources when necessary to fulfill its obligations under the Contract.

E. That it will submit reports as required by the Department's Rules and Regulations, furnish all relevant information as may from time to time be requested by the Department or the contracting agency, and in all respects comply with the Illinois Human Rights Act and Department's Rules and Regulations.

F. That it will permit access to all relevant books, records, accounts and work sites by personnel of the contracting agency and Department for purposes of investigation to ascertain compliance with the Illinois Human Rights Act and Department's Rules and Regulations.

G. That it will include verbatim or by reference the provisions of this Equal Employment Opportunity Clause in every subcontract it awards under which any portion of this Contract obligations are undertaken or assumed, so that such provisions will be binding upon such subcontractor. In the same manner as the other provisions of this Agreement, the Contractor will be liable for compliance with applicable provisions of this clause by such subcontractors; and further it will promptly notify the contracting agency and the Department in the event any subcontractor fails or refuses to comply therewith. In addition, the Contractor will not utilize any subcontractor declared by the Illinois Human Rights Department to be ineligible for contracts or subcontracts with the State of Illinois or any of its political subdivisions or municipal corporations.

ACKNOWLEDGED AND AGREED TO:

By: _____
Authorized Agent of Contractor (name and title)

DATE: _____

SEXUAL HARASSMENT POLICY

_____, having submitted a bid for _____ (Name of Contractor)
_____ to Community High School District No. 00, hereby
certifies that said contractor has a written sexual harassment policy in place in full compliance with 775 ILCS 5/2-
105 (A) (4).

By: _____
Authorized Agent of Contractor (name and title)

SUBSCRIBED AND SWORN to before
me this _____ day _____, 20____.

Notary Public

TAX CERTIFICATION

I, _____, having been first duly sworn depose and state as follows:

I, _____, am the duly authorized agent for
_____ which has submitted a proposal to Community
High School District No. 99 for

_____ and I hereby certify that
_____ is not delinquent in the payment of any tax administered by the
Illinois Department of Revenue, or if it is:

a. it is contesting its liability for the tax or the amount of tax in accordance with procedures established by the appropriate Revenue Act; or

b. it has entered into an agreement with the Department of Revenue for payment of all taxes due and is currently in compliance with that agreement.

By: _____
Authorized Agent of Contractor (name and title)

SUBSCRIBED AND SWORN to before
me this _____ day _____, 20__.

Notary Public

SUBSTANCE ABUSE PREVENTION ON PUBLIC WORKS PROJECTS

The Contractor certifies that it has in place a written program that meets or exceeds the program requirements of the Substance Abuse Prevention on Public Works Projects Act (Public Act 95-0635), and will provide a copy thereof to Community High School District No. 99 prior to commencement of work on the Project.

By: _____
Authorized Agent of Contractor (name and title)

SUBSCRIBED AND SWORN to before
me this _____ day _____, 20__.

Notary Public

**CERTIFICATE REGARDING
EMPLOYMENT OF ILLINOIS WORKERS ON PUBLIC WORKS**

_____ agrees if at the time the Agreement is executed, or if during the term of the Agreement, there is excessive unemployment in Illinois as defined in the Employment of Illinois Workers on Public Works Act, 30- ILCS 570/0/01 et seq., as two consecutive months of unemployment exceeding 5%, then _____ agrees to employ Illinois laborers in accordance with the Employment of Illinois Workers on Public Works Act. An "Illinois laborer" is defined as any person who has resided in Illinois for at least thirty (30) days and intends to become or remain an Illinois resident.

Firm: _____

By: _____
(Signature)

(Printed Name & Title)

SUBSCRIBED AND SWORN TO before me

This _____ day of _____, 2020

NOTARY PUBLIC

PREVAILING WAGE AFFIDAVIT

AFFIDAVIT: "I (we) hereby certify and affirm that if awarded a contract with Community High School District 99, we will comply fully with the "Illinois Prevailing Wage Act (Ill. Rev. Stat., 1987 Ch. 48, Sections 398 s-1-12 as amended by Public Act 86-693 and 86-799 effected January 1, 1990, and any other amendments effective thereafter)". We further understand that current prevailing wage standards are included in the Supplementary General Conditions.

The following affidavit must be signed and submitted with bidder's bid proposal. FAILURE TO DO SO MAY RESULT IN DISQUALIFICATION OF THE BIDDER.

_____, as part of its bid for the _____ work for Community High School District 99, Downers Grove, Illinois, certifies that said contractor is not barred from bidding on the aforementioned contract as a result of a violation of the Illinois Prevailing Wage Act (Ill. Rev. Stat., 1987 Ch. 48, Sections 398 s-1-12 as amended by Public Act 86-693 and 86-799 effected January 1, 1990).

Firm: _____

By: _____
(Signature)

(Printed Name & Title)

SUBSCRIBED AND SWORN TO before me

This _____ day of _____, 2020

NOTARY PUBLIC

NON-COLLUSION AFFIDAVIT

AFFIDAVIT: "I (we) hereby certify and affirm that my (our) proposal was prepared independently for this project and that it contains no fees or amounts other than that for the legitimate execution of this work as specified and that it includes no understanding or agreements in restraint of trade."

The following affidavit must be signed and submitted with bidder's bid proposal.
FAILURE TO DO SO MAY RESULT IN DISQUALIFICATION OF THE BIDDER.

_____, as a part of its bid for the _____ work for
Community High School District 99, Downers Grove, Illinois, certifies that said Contractor is not barred from bidding
on the aforementioned contract as a result of a violation of the above Non-Collusion Affidavit.

Firm: _____

By: _____
(Signature)

(Printed Name & Title)

SUBSCRIBED AND SWORN TO before me

This _____ day of _____, 2020

NOTARY PUBLIC

Criminal Background Investigations

Contractor hereby represents, warrants and certified that no officer or director thereof has any knowledge that any employee thereof has been convicted of committing or attempting to commit "Criminal Code of 1961," 720 ILCS, Sections 5/11-6 (Indecent solicitation of a child), 5/11-9 (Public indecency), 5/11-14 (Prostitution), 5/11-15 (Soliciting for a prostitute), 5/11-15.1 (Soliciting for a juvenile prostitute), 5/11-19 (Pimping), 5/11-19.1 (Juvenile pimping), 5/11-19.2 (Exploitation of a child), 5/11-20 (Obscenity), 5/11-20.1 (Sexual assault), 5/12-14 (Aggravated criminal sexual assault), 5/12-15 (Criminal sexual abuse), and 5/120-16 (Aggravated criminal sexual abuse), and/or those offenses defined in the "Cannabis Control Act," 720 ILCS, 550/1 et seq. (except the "Illinois Controlled Substances Act," 720 ILCS 570/100 et seq. and/or any offense committed or attempted in any other state or against the laws of the United States, which if committed or attempted in this State, would have been punishable as one or more of the foregoing offenses.

Contractor further agrees that it shall not employ any person who have or may have direct, daily contact with the pupils of any school in the district, and for whom a criminal background investigation has not been conducted pursuant hereto, and further represents and agrees that all applicants for any such employment shall furnish with their applications the attached written "Authorization for Criminal Background Information" form authorizing the Board of Education to request a criminal background investigation of said applicant pursuant to Section 5/10-21.9 of the School Code of Illinois and to receive criminal history record information pursuant thereto to determine if the applicant has been convicted of committing or attempting to commit any of the criminal or drug offenses enumerated above. Contractor further agrees to submit with said authorization payment for any costs and expenses associated with the criminal background investigation.

Contractor further represents, warrants, and certifies that no applicant for employment with respect to whom the criminal investigation reveals any conviction for committing and/or attempting to commit any of the above enumerated offenses shall be employed thereby in any position that involves or may involve contact with the students of the school district.

This certification is executed on the date hereinafter indicated by the designated contractor by its duly authorized officer.

Firm: _____

By: _____
(Signature)

(Printed Name & Title)

Date: _____

Criminal Background Investigation

The undersigned hereby authorizes in Board of Education of Community High School District 99, Downers Grove, Illinois, to request a criminal background investigation from the Illinois State Police, pursuant to Section 5/10-21.9 of the School Code of Illinois, 105 ILCS 5/10-21.9 and to receive criminal history record information pursuant thereto.

By: _____
(Signature of Applicant of Employee)

(Printed or Typed Name of Applicant Employee)

Date: _____

BUSINESS CLASSIFICATION

a) Business Entity (check one)

Corporation (Publicly held)* Not-for-Profit* Government Agency/Public Institution*
 Corporation (Privately held) Partnership Sole Proprietor

* If checked, do not complete section III (b) and (c) below.

b) Business Ownership (check one) If minority or woman owned, attach copy of certification evidence.

Large Business: Male Owned Woman Owned
Small Business: Male Owned Woman Owned

BUSINESS DEFINITIONS

Small Business Concern - an independently owned and operated concern certified, or certifiable, as a small business by the Federal Small Business Administration (SBA). Standard Industrial Classification (SIC) codes may be found in the Federal Acquisition Regulations, Section 19.102 or in the Federal Procurement Regulations, Section 1-1.701.

Small Disadvantaged or Minority Business Concern - a small business concern which is at least fifty-one percent (51%) owned by one or more socially and economically disadvantaged individuals or in the case of any publicly owned business, at least fifty-one percent (51%) of the stock of which is owned by such individuals; and whose management and daily business operations are controlled by one or more of such individuals. Business owners who certify that they are members of named groups (Black Americans, Hispanic Americans, Native Americans, Asian-Pacific Americans) are considered socially and economically disadvantaged.

Woman-Owned Business - a business concern that is at least fifty-one percent (51%) owned by a woman or women who also control and operate it. "Control" in this context means exercising the power to make policy decisions. "Operate" in this context means being actively involved in the day-to-day management.

c) Race/Ethnicity of Ownership (check one) based on definitions below.

Black Asian/Pacific or Asian/Indian Caucasian
 Hispanic Native American (American Indians, Eskimos, Aleuts and native Hawaiians)

ETHNIC GROUP DEFINITIONS

Black Americans: United States citizens whose origins are in any of the Black racial groups of Africa.
Hispanic Americans: United States citizens whose origins are in Mexico, Puerto Rico, Cuba, Portugal, Central or Central America.
Native Americans: United States citizens whose origins are in any of the original peoples of North America, i.e., American Indians, Eskimos, Aleuts and native Hawaiians.
Asian Pacific/Asian Indian Americans: United States citizens whose origins are in Japan, China, Korea, Taiwan, Cambodia, Laos, Vietnam, the Philippines, Samoa, Guam, the U.S. Trust Territories of the Pacific Islands, the Northern Mariana Islands, India, Pakistan, or Bangladesh.

I certify that the business classification and ethnicity indicated above reflects the true and correct status of this business in accordance with current Federal Small Business Administration criteria. I agree to inform Community High School District 99 immediately in writing of any changes to the information contained herein, including changes in ownership, controlling interest or operations. I understand that falsely certifying this information may result in suspension from participation in Community High School District 99 – South High School MFP Project.

Name: _____ Title: _____
(Print or Type)

Signature: _____ Date: _____

END OF SECTION 00301

BID DATE: February 7th, 2020 at 1:00 p.m. (CST)
(as date/time stamped by District 99's Receptionist)

BID TO: Community High School District 99
Administrative Center
6301 Springside Avenue
Downers Grove, IL 60516

RECEIVED BY:

BID FROM: _____

BID FOR: ***Bid Group #9 Bid Package #110 Theatre Platforms
Phase C***

South High School
1436 Norfolk Street
Downers Grove, IL 60516

It is required to have one original and one copy of your bid form.

THE UNDERSIGNED:

Acknowledges receipt of:

Plans and specifications for the work indicated above.

Addenda: No. _____ dated _____
No. _____ dated _____
No. _____ dated _____
No. _____ dated _____

Having examined the site of the work, and having familiarized himself or herself with local conditions affecting the cost of the work and with all requirements of the bidding documents including Instructions to Bidders, drawings, specifications and duly issued addenda as prepared by the architect, Wight & Company, hereby agrees to perform all work and furnish all labor, material and equipment specifically required of him by the bidding documents and such additional work as may be included as related requirements in other divisions or sections of the specifications, exclusive of alternate bids.

Agrees:

To furnish and install the described material and/or services for stated lump sum price.

To hold this bid open until **90** calendar days after bid opening date.

DIVISION 0 – BIDDING & CONTRACT REQUIREMENTS
SECTION 03110 - BID FORM

To accept the provisions of the General Provisions (Project Manual Division 0 – Bidding & Contracting Requirements Section 00201) and disposition of bid security.

To enter into and execute a contract with the Owner, if awarded on the basis of this bid, and in connection therewith to:

1. Furnish all bonds and insurance required by the bidding documents.
2. Accomplish the work in accordance with the contract.
3. Complete the work within the contract time herein specified.

Completion Time:

The undersigned agrees to begin construction immediately, or as directed by the Construction Manager, upon notice of contract award and to perform the following components of the work in accordance with the Construction Manager's Construction. This schedule is bound in the Project Manual. See attached scope of work in section 0300.

SCOPE OF WORK:

The work in this agreement (without additional compensation) shall include, but shall not necessarily be limited to, all skilled labor, supervision, premium time, materials, tools, equipment, plant, supplies, samples, shop drawings, design/engineering drawings, layout, transportation, supervision, contributions, insurance, taxes (if applicable), compliance with all agencies (City / Village, County, State, Federal and/or any other jurisdictional agency, as may be required) and/or all services and facilities necessary and/or required for the performance of all Work shown, detailed, and/or implied by the following documents and as defined herein.

It is understood that this Trade Contractor shall perform the Work for a complete and operational system as indicated or implied in all Contract Documents. It is recognized and understood that the documents upon which the bid is based are at a conceptual phase and this Contractor who has certain skills and judgments based upon his knowledge of techniques, procedures, systems, general state of the art of his specialty is expected to include in the scope of work, all items required in order to carry out a complete and functional system whether or not shown or described in the contract documents. This contract will be awarded on the basis of such documents with the understanding that this contractor is to furnish and install all items required for the proper completion of this work without adjustment to this contract price. No extra payments shall be made of claims entertained as a result of such items, unless it can be clearly demonstrated to be added scope to the contract and beyond the original intent of the documents.

Contractor to provide all Trade Contract work referenced in:

1. Any sheet of this bid group package including (reference Division 0 – Bidding and Contract Requirements, Section 00200 – Notice to Bidders).
2. Specification 00300 Bid Packages Scope Document.

WORK BASE BID: For providing all work including all allowances as required for the completion of the construction of the base bid project as shown on the drawings and specifications and NOT including alternate bids and/or contractor's proposed alternates and substitutes.

BASE BID

TOTAL BASE BID AMOUNT SOUTH HIGH SCHOOL MASTER FACILITY PLAN

_____ Dollars (\$ _____)

1. This TRADE CONTRACTOR shall include an allowance of **\$5,000.00 in their base bid** to account for any unforeseen conditions. Contract amounts will be adjusted by change order for amounts greater or less than the allowance. Allowance to be utilized only at the direction of Construction Manager.
2. This TRADE CONTRACTOR shall provide an **Alternate No. 8.2 PLATFORMING ADDITIVE ALTERNATE** and fill this in the appropriate spot on the bid form.

ADD _____ Dollars (\$ _____)

BONDS:

This TRADE CONTRACTOR will be required to provide a Performance and Payment Bond for their work in accordance with 00201 of the General Conditions.

Award Basis:

The project will be awarded based upon the attached Evaluation Criteria, Section 301a. Owner and Construction Manager alternate's may be considered to find the most qualified bidder if the result of combining the base bid and the selected alternate(s) is the most qualified bid, and is to the benefit of the owner.

Each of the following amounts for alternate construction includes the entire cost of such construction, except as otherwise noted. Acceptance of any or all of the alternates for inclusion in the contract is the sole prerogative of the owner.

All additional costs due to the alternates are included in the amount to be added to the base bid, so that no additional costs will be borne by the owner due to acceptance of alternates. This alternate price is not to be included in the base bid price.

Owner Requested Alternates:

Each of the following amounts for alternate construction includes the entire cost of such construction, except as otherwise noted. Acceptance of any or all of the alternates for inclusion in the contract is the sole prerogative of the owner.

All additional costs due to the alternates are included in the amount to be added to the base bid, so that no additional costs will be borne by the owner due to acceptance of alternates.

Proposed Alternates: (Contractors Proposed Alternates)

Item Specified	Proposed Alternate	Change in Bid Price
1. _____	_____	_____
2. _____	_____	_____
3. _____	_____	_____

Owner Requested Unit Prices/Allowances (as applicable to this Trade Contractor's scope of work) (additive or deductive).

This trade contractor includes _____ dumpsters for all refuse caused by this trade contractor's work in the amount of _____ Dollars (\$ _____) Note: trade contractors are to include in their bid form submittal the quantity of dumpsters required to complete their work and the cost associated with same. Dumpster costs will be subtracted by

change order. Dumpsters will be procured and managed by Construction Manager. Note: Dumpster use in excess of that proposed by this Trade Contractor will be adjusted by back charge.

Owner Requested Scheduling Information:

Note: The work of this Trade Contractor is to be completed in accordance with the overall project schedule as identified elsewhere in this project manual and/or as subsequently directed by Construction Manager. This Trade Contractor shall submit a proposed submittals list/schedule/material log within five (5) calendar days of Notice To Proceed.

1. Shop drawings / Submittal for this trade contractor will be submitted within 10 calendar days of receipt of notice to proceed.

Bid Acceptance:

If written notice of the acceptance of this bid is mailed, telegraphed or delivered to the undersigned within the time noted herein, after the date of opening of bids or at any time thereafter before this bid is withdrawn, the undersigned agrees that he will execute a construction contract in accordance with the bids as accepted.

The Owner reserves the right to award the contract to its best interests, review and accept any and all value engineering alternatives, negotiate with the lowest responsible bidder, to reject any or all bids, to waive any informalities in bidding and to hold all bids for the bid guarantee period. The Owner reserves the right to award separate contracts for any of the items of work bid herein.

Bid Deposit:

The undersigned furnishes herewith, as required in the Instructions to Bidders, a bid deposit in the amount of ten percent (10%) of the amount bid in the form of Cashier's Check, or Certified Check, made payable to the Owner or Bid Bond, naming the Owner as obligee. (Bidder to check form of deposit furnished.)

It is understood and agreed that should the undersigned fail to enter into a contract with the Owner or furnish acceptable contract security within the time and in the manner herein provided, the bid deposit shall be retained by the Owner as liquidated damages and not as a forfeiture. As it is impossible to determine precisely an exact amount of damages the Owner will sustain, it is agreed that the bid deposit is a fair and equitable estimate of such damages.

REPRESENTATIONS AND CERTIFICATIONS:

The bidder makes the following representations and certifications as part of his bid on the project herein identified in the Bid Form. In the case of a joint venture bid, each party represents and certifies as to his own organization.

AVAILABILITY. The number and amount of contracts and awards pending which I am and/or will be obligated to perform, now and during the course of the project, will not interfere with or hinder the timely prosecution of my work.

SURETY. I have notified a Surety Company that I am submitting a bid for work to be performed on the project. The Surety Company has agreed to issue a performance and labor and material payment bond for my work, if my bid is accepted and the contract awarded to me.

INDEPENDENT PRICE DETERMINATION. The contract sum in this bid has been arrived at independently, without consultation, communication or agreement for the purpose of restricting competition.

PREVAILING WAGE. The contractor and each subcontractor shall pay not less than the general prevailing rate of hourly wages for work of a similar character in the locality in which the work is performed and not less than general prevailing rate of hourly wages for legal holidays and overtime work in the performance of work under this contract, as established by the Illinois Department of Labor, pursuant to an act of the General Assembly of the State of Illinois approved June 26, 1941 as amended according to Section 820 ILCS 130/1.

DIVISION 0 – BIDDING & CONTRACT REQUIREMENTS
SECTION 03110 - BID FORM

Pursuant to Section 820 ILCS 130/5, the contractor and each subcontractor shall keep an accurate record showing the names and occupation of all laborers, workers and mechanics employed by them, and also showing the actual hourly wages paid to each such individual, which record shall be open at all reasonable hours to inspection by the Owner, its officers and agents, and to agents of the Illinois Department of Labor.

The contractor and each subcontractor hereby agree, jointly and severally, to defend, indemnify and hold harmless the Owner from any and all claims, demands, liens or suits of any kind or nature whatsoever (including suits for injunctive relief) by the Illinois Department of Labor under the Illinois Prevailing Wage Act, Section 820 ILCS 130/1., or by any laborer, worker or mechanic employed by the contractor or the subcontractor who alleges that he has been paid for his services in a sum less than prevailing wage rates required by Illinois law. The Owner agrees to notify the contractor or subcontractor of the pendency of any such claim, demand, lien or suit.

DIVISION 0 – BIDDING & CONTRACT REQUIREMENTS
SECTION 03110 - BID FORM

By submitting a bid, each bidder agrees to waive any claim it has or may have against the Owner, the Architect, Engineer, Construction Manager and their respective employees, arising out of or in connection with the administration, evaluation, or recommendation of any bid; waiver of any requirements under the Bid Documents; or the Contract Document; acceptance or rejection of any bids; and award of the Contract.

Signature:

Respectfully submitted this _____ day _____, 2020

Type of Firm (Bidder to indicate)

_____ Individual

_____ Partnership

_____ Corporation

_____ Joint Venture

_____ Other

(CORPORATE SEAL)

(Firm Name)

(Address)

(Telephone Number) (FAX)

(E-mail Address)

(Bidder's Signature)

(Title)

Subscribed and sworn to me
this _____ day of _____, 2020

NOTE: All pages of this bid form must be returned with your proposal. Failure to do so shall disqualify your bid.

CERTIFICATE OF BIDDER ELIGIBILITY

720 ILCS 5/33E-11 REQUIRES THAT ALL CONTRACTORS BIDDING FOR PUBLIC AGENCIES IN THE State of Illinois certify that they are not barred from bidding on public contracts for bid rigging or bid rotation.

The following certification must be signed and submitted with bidder's bid proposal. FAILURE TO DO SO MAY RESULT IN DISQUALIFICATION OF THE BIDDER.

_____, as part of its bid for the _____ work for Community High School District 99, Downers Grove, Illinois, DuPage County, Illinois certified that said contractor is not barred from bidding on the aforementioned contract as a result of violation of either 720 ILCS 5/33E-3 or 720 ILCS 5/33-E4.

Firm: _____

By: _____
(Signature)

(Printed Name & Title)

SUBSCRIBED AND SWORN TO before me

This _____ day of _____, 2020

NOTARY PUBLIC

**CRIMINAL CODE CERTIFICATION
AS REQUIRED BY:
STATE OF ILLINOIS CRIMINAL CODE OF 2012, 720 ILCS 5/33E-11**

I, _____ the individual whose signature appears below on this bid/contract
for _____ hereby certify that the bidding
party/contracting party is not barred from bidding on the contract as a result of a violation of either Section 33E-3 or
Section 33E-4 of 720 ILCS 5/33E-3 or 5/33E-4 of the Illinois Compiled Statutes, as amended.

By: _____
Authorized Agent of Contractor (name and title)

SUBSCRIBED AND SWORN to before
me this ____ day _____, 20__.

Notary Public

EQUAL EMPLOYMENT OPPORTUNITY

Section I. This EQUAL EMPLOYMENT OPPORTUNITY CLAUSE is required by the Illinois Human Rights Act and the Rules and Regulations of the Illinois Department of Human Rights published at 44 Illinois Administrative Code Section 750, *et seq.*

Section II. In the event of the Contractor's noncompliance with any provision of this Equal Employment Opportunity Clause, the Illinois Human Rights Act, or the Rules and Regulations of the Department of Human Rights (hereinafter referred to as the Department) the Contractor may be declared ineligible for future contracts or subcontracts with the State of Illinois or any of its political subdivisions or municipal corporations, and this Contract may be canceled or voided in whole or in part, and other sanctions or penalties may be imposed or remedies involved as provided by statute or regulation.

During the performance of this Agreement, the Contractor agrees:

A. That it will not discriminate against any employee or applicant for employment because of race, color, religion, sex, sexual orientation, national origin or ancestry, citizenship status, age, physical or mental disability unrelated to ability, military status or an unfavorable discharge from military service; and further that it will examine all job classifications to determine if minority persons or women are underutilized and will take appropriate affirmative action to rectify any such underutilization.

B. That, if it hires additional employees in order to perform this Contract, or any portion hereof, it will determine the availability (in accordance with the Department's Rules and Regulations) of minorities and women in the area(s) from which it may reasonably recruit and it will hire for each job classification for which employees are hired in such a way that minorities and women are not underutilized.

C. That, in all solicitations or advertisements for employees placed by it or on its behalf, it will state that all applicants will be afforded equal opportunity without discrimination because of race, color, religion, sex, sexual orientation, marital status, national origin or ancestry, citizenship status, age, or physical or mental handicap unrelated to ability, military status or an unfavorable discharge from military service.

D. That it will send to each labor organization or representative of workers with which it has or is bound by a collective bargaining or other agreement or understanding, a notice advising such labor organization or representative of the Vendor's obligations under the Illinois Human Rights Act and Department's Rules and Regulations. If any labor organization or representative fails or refuses to cooperate with the Contractor in its efforts to comply with the Act and Rules and Regulations, the Contractor will promptly notify the Department and the contracting agency and will recruit employees from other sources when necessary to fulfill its obligations under the Contract.

E. That it will submit reports as required by the Department's Rules and Regulations, furnish all relevant information as may from time to time be requested by the Department or the contracting agency, and in all respects comply with the Illinois Human Rights Act and Department's Rules and Regulations.

F. That it will permit access to all relevant books, records, accounts and work sites by personnel of the contracting agency and Department for purposes of investigation to ascertain compliance with the Illinois Human Rights Act and Department's Rules and Regulations.

G. That it will include verbatim or by reference the provisions of this Equal Employment Opportunity Clause in every subcontract it awards under which any portion of this Contract obligations are undertaken or assumed, so that such provisions will be binding upon such subcontractor. In the same manner as the other provisions of this Agreement, the Contractor will be liable for compliance with applicable provisions of this clause by such subcontractors; and further it will promptly notify the contracting agency and the Department in the event any subcontractor fails or refuses to comply therewith. In addition, the Contractor will not utilize any subcontractor declared by the Illinois Human Rights Department to be ineligible for contracts or subcontracts with the State of Illinois or any of its political subdivisions or municipal corporations.

ACKNOWLEDGED AND AGREED TO:

By: _____
Authorized Agent of Contractor (name and title)

DATE: _____

SEXUAL HARASSMENT POLICY

_____, having submitted a bid for _____ (Name of Contractor)
_____ to Community High School District No. 00, hereby
certifies that said contractor has a written sexual harassment policy in place in full compliance with 775 ILCS 5/2-
105 (A) (4).

By: _____
Authorized Agent of Contractor (name and title)

SUBSCRIBED AND SWORN to before
me this _____ day _____, 20____.

Notary Public

TAX CERTIFICATION

I, _____, having been first duly sworn depose and state as follows:

I, _____, am the duly authorized agent for
_____ which has submitted a proposal to Community
High School District No. 99 for

_____ and I hereby certify that
_____ is not delinquent in the payment of any tax administered by the
Illinois Department of Revenue, or if it is:

a. it is contesting its liability for the tax or the amount of tax in accordance with procedures established by the appropriate Revenue Act; or

b. it has entered into an agreement with the Department of Revenue for payment of all taxes due and is currently in compliance with that agreement.

By: _____
Authorized Agent of Contractor (name and title)

SUBSCRIBED AND SWORN to before
me this _____ day _____, 20__.

Notary Public

SUBSTANCE ABUSE PREVENTION ON PUBLIC WORKS PROJECTS

The Contractor certifies that it has in place a written program that meets or exceeds the program requirements of the Substance Abuse Prevention on Public Works Projects Act (Public Act 95-0635), and will provide a copy thereof to Community High School District No. 99 prior to commencement of work on the Project.

By: _____
Authorized Agent of Contractor (name and title)

SUBSCRIBED AND SWORN to before
me this _____ day _____, 20__.

Notary Public

**CERTIFICATE REGARDING
EMPLOYMENT OF ILLINOIS WORKERS ON PUBLIC WORKS**

_____ agrees if at the time the Agreement is executed, or if during the term of the Agreement, there is excessive unemployment in Illinois as defined in the Employment of Illinois Workers on Public Works Act, 30- ILCS 570/0/01 et seq., as two consecutive months of unemployment exceeding 5%, then _____ agrees to employ Illinois laborers in accordance with the Employment of Illinois Workers on Public Works Act. An "Illinois laborer" is defined as any person who has resided in Illinois for at least thirty (30) days and intends to become or remain an Illinois resident.

Firm: _____

By: _____
(Signature)

(Printed Name & Title)

SUBSCRIBED AND SWORN TO before me

This _____ day of _____, 2020

NOTARY PUBLIC

PREVAILING WAGE AFFIDAVIT

AFFIDAVIT: "I (we) hereby certify and affirm that if awarded a contract with Community High School District 99, we will comply fully with the "Illinois Prevailing Wage Act (Ill. Rev. Stat., 1987 Ch. 48, Sections 398 s-1-12 as amended by Public Act 86-693 and 86-799 effected January 1, 1990, and any other amendments effective thereafter)". We further understand that current prevailing wage standards are included in the Supplementary General Conditions.

The following affidavit must be signed and submitted with bidder's bid proposal. FAILURE TO DO SO MAY RESULT IN DISQUALIFICATION OF THE BIDDER.

_____, as part of its bid for the _____ work for Community High School District 99, Downers Grove, Illinois, certifies that said contractor is not barred from bidding on the aforementioned contract as a result of a violation of the Illinois Prevailing Wage Act (Ill. Rev. Stat., 1987 Ch. 48, Sections 398 s-1-12 as amended by Public Act 86-693 and 86-799 effected January 1, 1990).

Firm: _____

By: _____
(Signature)

(Printed Name & Title)

SUBSCRIBED AND SWORN TO before me

This _____ day of _____, 2020

NOTARY PUBLIC

NON-COLLUSION AFFIDAVIT

AFFIDAVIT: "I (we) hereby certify and affirm that my (our) proposal was prepared independently for this project and that it contains no fees or amounts other than that for the legitimate execution of this work as specified and that it includes no understanding or agreements in restraint of trade."

The following affidavit must be signed and submitted with bidder's bid proposal.
FAILURE TO DO SO MAY RESULT IN DISQUALIFICATION OF THE BIDDER.

_____, as a part of its bid for the _____ work for
Community High School District 99, Downers Grove, Illinois, certifies that said Contractor is not barred from bidding
on the aforementioned contract as a result of a violation of the above Non-Collusion Affidavit.

Firm: _____

By: _____
(Signature)

(Printed Name & Title)

SUBSCRIBED AND SWORN TO before me

This _____ day of _____, 2020

NOTARY PUBLIC

Criminal Background Investigations

Contractor hereby represents, warrants and certified that no officer or director thereof has any knowledge that any employee thereof has been convicted of committing or attempting to commit "Criminal Code of 1961," 720 ILCS, Sections 5/11-6 (Indecent solicitation of a child), 5/11-9 (Public indecency), 5/11-14 (Prostitution), 5/11-15 (Soliciting for a prostitute), 5/11-15.1 (Soliciting for a juvenile prostitute), 5/11-19 (Pimping), 5/11-19.1 (Juvenile pimping), 5/11-19.2 (Exploitation of a child), 5/11-20 (Obscenity), 5/11-20.1 (Sexual assault), 5/12-14 (Aggravated criminal sexual assault), 5/12-15 (Criminal sexual abuse), and 5/120-16 (Aggravated criminal sexual abuse), and/or those offenses defined in the "Cannabis Control Act," 720 ILCS, 550/1 et seq. (except the "Illinois Controlled Substances Act," 720 ILCS 570/100 et seq. and/or any offense committed or attempted in any other state or against the laws of the United States, which if committed or attempted in this State, would have been punishable as one or more of the foregoing offenses.

Contractor further agrees that it shall not employ any person who have or may have direct, daily contact with the pupils of any school in the district, and for whom a criminal background investigation has not been conducted pursuant hereto, and further represents and agrees that all applicants for any such employment shall furnish with their applications the attached written "Authorization for Criminal Background Information" form authorizing the Board of Education to request a criminal background investigation of said applicant pursuant to Section 5/10-21.9 of the School Code of Illinois and to receive criminal history record information pursuant thereto to determine if the applicant has been convicted of committing or attempting to commit any of the criminal or drug offenses enumerated above. Contractor further agrees to submit with said authorization payment for any costs and expenses associated with the criminal background investigation.

Contractor further represents, warrants, and certifies that no applicant for employment with respect to whom the criminal investigation reveals any conviction for committing and/or attempting to commit any of the above enumerated offenses shall be employed thereby in any position that involves or may involve contact with the students of the school district.

This certification is executed on the date hereinafter indicated by the designated contractor by its duly authorized officer.

Firm: _____

By: _____
(Signature)

(Printed Name & Title)

Date: _____

Criminal Background Investigation

The undersigned hereby authorizes in Board of Education of Community High School District 99, Downers Grove, Illinois, to request a criminal background investigation from the Illinois State Police, pursuant to Section 5/10-21.9 of the School Code of Illinois, 105 ILCS 5/10-21.9 and to receive criminal history record information pursuant thereto.

By: _____
(Signature of Applicant of Employee)

(Printed or Typed Name of Applicant Employee)

Date: _____

BUSINESS CLASSIFICATION

a) Business Entity (check one)

Corporation (Publicly held)* Not-for-Profit* Government Agency/Public Institution*
 Corporation (Privately held) Partnership Sole Proprietor

* If checked, do not complete section III (b) and (c) below.

b) Business Ownership (check one) If minority or woman owned, attach copy of certification evidence.

Large Business: Male Owned Woman Owned
Small Business: Male Owned Woman Owned

BUSINESS DEFINITIONS

Small Business Concern - an independently owned and operated concern certified, or certifiable, as a small business by the Federal Small Business Administration (SBA). Standard Industrial Classification (SIC) codes may be found in the Federal Acquisition Regulations, Section 19.102 or in the Federal Procurement Regulations, Section 1-1.701.

Small Disadvantaged or Minority Business Concern - a small business concern which is at least fifty-one percent (51%) owned by one or more socially and economically disadvantaged individuals or in the case of any publicly owned business, at least fifty-one percent (51%) of the stock of which is owned by such individuals; and whose management and daily business operations are controlled by one or more of such individuals. Business owners who certify that they are members of named groups (Black Americans, Hispanic Americans, Native Americans, Asian-Pacific Americans) are considered socially and economically disadvantaged.

Woman-Owned Business - a business concern that is at least fifty-one percent (51%) owned by a woman or women who also control and operate it. "Control" in this context means exercising the power to make policy decisions. "Operate" in this context means being actively involved in the day-to-day management.

c) Race/Ethnicity of Ownership (check one) based on definitions below.

Black Asian/Pacific or Asian/Indian Caucasian
 Hispanic Native American (American Indians, Eskimos, Aleuts and native Hawaiians)

ETHNIC GROUP DEFINITIONS

Black Americans: United States citizens whose origins are in any of the Black racial groups of Africa.

Hispanic Americans: United States citizens whose origins are in Mexico, Puerto Rico, Cuba, Portugal, Central or Central America.

Native Americans: United States citizens whose origins are in any of the original peoples of North America, i.e., American Indians, Eskimos, Aleuts and native Hawaiians.

Asian Pacific/Asian Indian Americans: United States citizens whose origins are in Japan, China, Korea, Taiwan, Cambodia, Laos, Vietnam, the Philippines, Samoa, Guam, the U.S. Trust Territories of the Pacific Islands, the Northern Mariana Islands, India, Pakistan, or Bangladesh.

I certify that the business classification and ethnicity indicated above reflects the true and correct status of this business in accordance with current Federal Small Business Administration criteria. I agree to inform Community High School District 99 immediately in writing of any changes to the information contained herein, including changes in ownership, controlling interest or operations. I understand that falsely certifying this information may result in suspension from participation in Community High School District 99 – South High School MFP Project.

Name: _____ Title: _____
(Print or Type)

Signature: _____ Date: _____

END OF SECTION 00301

BID DATE: February 7th, 2020 at 1:00 p.m. (CST)
(as date/time stamped by District 99's Receptionist)

BID TO: Community High School District 99
Administrative Center
6301 Springside Avenue
Downers Grove, IL 60516

RECEIVED BY:

BID FROM: _____

BID FOR: ***Bid Group #9 Bid Package #111 Theatre Rigging
Phase C***

South High School
1436 Norfolk Street
Downers Grove, IL 60516

It is required to have one original and one copy of your bid form.

THE UNDERSIGNED:

Acknowledges receipt of:

Plans and specifications for the work indicated above.

Addenda: No. _____ dated _____
No. _____ dated _____
No. _____ dated _____
No. _____ dated _____

Having examined the site of the work, and having familiarized himself or herself with local conditions affecting the cost of the work and with all requirements of the bidding documents including Instructions to Bidders, drawings, specifications and duly issued addenda as prepared by the architect, Wight & Company, hereby agrees to perform all work and furnish all labor, material and equipment specifically required of him by the bidding documents and such additional work as may be included as related requirements in other divisions or sections of the specifications, exclusive of alternate bids.

Agrees:

To furnish and install the described material and/or services for stated lump sum price.

To hold this bid open until **90** calendar days after bid opening date.

DIVISION 0 – BIDDING & CONTRACT REQUIREMENTS
SECTION 03111 - BID FORM

To accept the provisions of the General Provisions (Project Manual Division 0 – Bidding & Contracting Requirements Section 00201) and disposition of bid security.

To enter into and execute a contract with the Owner, if awarded on the basis of this bid, and in connection therewith to:

1. Furnish all bonds and insurance required by the bidding documents.
2. Accomplish the work in accordance with the contract.
3. Complete the work within the contract time herein specified.

Completion Time:

The undersigned agrees to begin construction immediately, or as directed by the Construction Manager, upon notice of contract award and to perform the following components of the work in accordance with the Construction Manager's Construction. This schedule is bound in the Project Manual. See attached scope of work in section 0300.

SCOPE OF WORK:

The work in this agreement (without additional compensation) shall include, but shall not necessarily be limited to, all skilled labor, supervision, premium time, materials, tools, equipment, plant, supplies, samples, shop drawings, design/engineering drawings, layout, transportation, supervision, contributions, insurance, taxes (if applicable), compliance with all agencies (City / Village, County, State, Federal and/or any other jurisdictional agency, as may be required) and/or all services and facilities necessary and/or required for the performance of all Work shown, detailed, and/or implied by the following documents and as defined herein.

It is understood that this Trade Contractor shall perform the Work for a complete and operational system as indicated or implied in all Contract Documents. It is recognized and understood that the documents upon which the bid is based are at a conceptual phase and this Contractor who has certain skills and judgments based upon his knowledge of techniques, procedures, systems, general state of the art of his specialty is expected to include in the scope of work, all items required in order to carry out a complete and functional system whether or not shown or described in the contract documents. This contract will be awarded on the basis of such documents with the understanding that this contractor is to furnish and install all items required for the proper completion of this work without adjustment to this contract price. No extra payments shall be made of claims entertained as a result of such items, unless it can be clearly demonstrated to be added scope to the contract and beyond the original intent of the documents.

Contractor to provide all Trade Contract work referenced in:

1. Any sheet of this bid group package including (reference Division 0 – Bidding and Contract Requirements, Section 00200 – Notice to Bidders).
2. Specification 00300 Bid Packages Scope Document.

WORK BASE BID: For providing all work including all allowances as required for the completion of the construction of the base bid project as shown on the drawings and specifications and NOT including alternate bids and/or contractor's proposed alternates and substitutes.

BASE BID

TOTAL BASE BID AMOUNT SOUTH HIGH SCHOOL MASTER FACILITY PLAN

_____ Dollars (\$ _____)

1. This TRADE CONTRACTOR **shall include an allowance of \$10,000.00 in their base bid** to account for any unforeseen conditions. Contract amounts will be adjusted by change order for amounts greater or less than the allowance. Allowance to be utilized only at the direction of Construction Manager.
2. This TRADE CONTRACTOR shall provide an **Alternate No. 8.4 STAGE RIGGING DEDUCTIVE ALTERNATE** and fill this in the appropriate spot on the bid form.

DEDUCT _____ Dollars(\$ _____)

3. **Alternate 2:** This TRADE CONTRACTOR shall provide an alternate price for furnishing and installing the box boom lighting positions and all associated steel for the auditorium.

ADD/DEDUCT _____ Dollars(\$ _____)

4. **Alternate 3:** This TRADE CONTRACTOR shall provide an alternate price for furnishing and installing the pipe grid system as shown on A3.11 for the Theatre Classroom.

ADD/DEDUCT _____ Dollars(\$ _____)

BONDS:

This TRADE CONTRACTOR will be required to provide a Performance and Payment Bond for their work in accordance with 00201 of the General Conditions.

Award Basis:

The project will be awarded based upon the attached Evaluation Criteria, Section 301a. Owner and Construction Manager alternate's may be considered to find the most qualified bidder if the result of combining the base bid and the selected alternate(s) is the most qualified bid, and is to the benefit of the owner.

Each of the following amounts for alternate construction includes the entire cost of such construction, except as otherwise noted. Acceptance of any or all of the alternates for inclusion in the contract is the sole prerogative of the owner.

All additional costs due to the alternates are included in the amount to be added to the base bid, so that no additional costs will be borne by the owner due to acceptance of alternates. This alternate price is not to be included in the base bid price.

Owner Requested Alternates:

Each of the following amounts for alternate construction includes the entire cost of such construction, except as otherwise noted. Acceptance of any or all of the alternates for inclusion in the contract is the sole prerogative of the owner.

All additional costs due to the alternates are included in the amount to be added to the base bid, so that no additional costs will be borne by the owner due to acceptance of alternates.

Proposed Alternates: (Contractors Proposed Alternates)

	Item Specified	Proposed Alternate	Change in Bid Price
1.	_____	_____	_____
2.	_____	_____	_____

3. _____

Owner Requested Unit Prices/Allowances (as applicable to this Trade Contractor's scope of work) (additive or deductive).

This trade contractor includes _____ dumpsters for all refuse caused by this trade contractor's work in the amount of _____ Dollars (\$ _____) Note: trade contractors are to include in their bid form submittal the quantity of dumpsters required to complete their work and the cost associated with same. Dumpster costs will be subtracted by change order. Dumpsters will be procured and managed by Construction Manager. Note: Dumpster use in excess of that proposed by this Trade Contractor will be adjusted by back charge.

Owner Requested Scheduling Information:

Note: The work of this Trade Contractor is to be completed in accordance with the overall project schedule as identified elsewhere in this project manual and/or as subsequently directed by Construction Manager. This Trade Contractor shall submit a proposed submittals list/schedule/material log within five (5) calendar days of Notice To Proceed.

1. Shop drawings / Submittal for this trade contractor will be submitted within 10 calendar days of receipt of notice to proceed.

Bid Acceptance:

If written notice of the acceptance of this bid is mailed, telegraphed or delivered to the undersigned within the time noted herein, after the date of opening of bids or at any time thereafter before this bid is withdrawn, the undersigned agrees that he will execute a construction contract in accordance with the bids as accepted.

The Owner reserves the right to award the contract to its best interests, review and accept any and all value engineering alternatives, negotiate with the lowest responsible bidder, to reject any or all bids, to waive any informalities in bidding and to hold all bids for the bid guarantee period. The Owner reserves the right to award separate contracts for any of the items of work bid herein.

Bid Deposit:

The undersigned furnishes herewith, as required in the Instructions to Bidders, a bid deposit in the amount of ten percent (10%) of the amount bid in the form of Cashier's Check, or Certified Check, made payable to the Owner or Bid Bond, naming the Owner as obligee. (Bidder to check form of deposit furnished.)

It is understood and agreed that should the undersigned fail to enter into a contract with the Owner or furnish acceptable contract security within the time and in the manner herein provided, the bid deposit shall be retained by the Owner as liquidated damages and not as a forfeiture. As it is impossible to determine precisely an exact amount of damages the Owner will sustain, it is agreed that the bid deposit is a fair and equitable estimate of such damages.

REPRESENTATIONS AND CERTIFICATIONS:

The bidder makes the following representations and certifications as part of his bid on the project herein identified in the Bid Form. In the case of a joint venture bid, each party represents and certifies as to his own organization.

AVAILABILITY. The number and amount of contracts and awards pending which I am and/or will be obligated to perform, now and during the course of the project, will not interfere with or hinder the timely prosecution of my work.

SURETY. I have notified a Surety Company that I am submitting a bid for work to be performed on the project. The Surety Company has agreed to issue a performance and labor and material payment bond for my work, if my bid is accepted and the contract awarded to me.

INDEPENDENT PRICE DETERMINATION. The contract sum in this bid has been arrived at independently, without consultation, communication or agreement for the purpose of restricting competition.

PREVAILING WAGE. The contractor and each subcontractor shall pay not less than the general prevailing rate of hourly wages for work of a similar character in the locality in which the work is performed and not less than general prevailing rate of hourly wages for legal holidays and overtime work in the performance of work under this contract, as established by the Illinois Department of Labor, pursuant to an act of the General Assembly of the State of Illinois approved June 26, 1941 as amended according to Section 820 ILCS 130/1.

Pursuant to Section 820 ILCS 130/5, the contractor and each subcontractor shall keep an accurate record showing the names and occupation of all laborers, workers and mechanics employed by them, and also showing the actual hourly wages paid to each such individual, which record shall be open at all reasonable hours to inspection by the Owner, its officers and agents, and to agents of the Illinois Department of Labor.

The contractor and each subcontractor hereby agree, jointly and severally, to defend, indemnify and hold harmless the Owner from any and all claims, demands, liens or suits of any kind or nature whatsoever (including suits for injunctive relief) by the Illinois Department of Labor under the Illinois Prevailing Wage Act, Section 820 ILCS 130/1., or by any laborer, worker or mechanic employed by the contractor or the subcontractor who alleges that he has been paid for his services in a sum less than prevailing wage rates required by Illinois law. The Owner agrees to notify the contractor or subcontractor of the pendency of any such claim, demand, lien or suit.

DIVISION 0 – BIDDING & CONTRACT REQUIREMENTS
SECTION 03111 - BID FORM

By submitting a bid, each bidder agrees to waive any claim it has or may have against the Owner, the Architect, Engineer, Construction Manager and their respective employees, arising out of or in connection with the administration, evaluation, or recommendation of any bid; waiver of any requirements under the Bid Documents; or the Contract Document; acceptance or rejection of any bids; and award of the Contract.

Signature:

Respectfully submitted this _____ day _____, 2020

Type of Firm (Bidder to indicate)

_____ Individual

_____ Partnership

_____ Corporation

_____ Joint Venture

_____ Other

(Firm Name)

(Address)

(CORPORATE SEAL)

(Telephone Number) (FAX)

(E-mail Address)

(Bidder's Signature)

(Title)

Subscribed and sworn to me
this _____ day of _____, 2020

NOTE: All pages of this bid form must be returned with your proposal. Failure to do so shall disqualify your bid.

CERTIFICATE OF BIDDER ELIGIBILITY

720 ILCS 5/33E-11 REQUIRES THAT ALL CONTRACTORS BIDDING FOR PUBLIC AGENCIES IN THE State of Illinois certify that they are not barred from bidding on public contracts for bid rigging or bid rotation.

The following certification must be signed and submitted with bidder's bid proposal. FAILURE TO DO SO MAY RESULT IN DISQUALIFICATION OF THE BIDDER.

_____, as part of its bid for the _____ work for Community High School District 99, Downers Grove, Illinois, DuPage County, Illinois certified that said contractor is not barred from bidding on the aforementioned contract as a result of violation of either 720 ILCS 5/33E-3 or 720 ILCS 5/33-E4.

Firm: _____

By: _____
(Signature)

(Printed Name & Title)

SUBSCRIBED AND SWORN TO before me

This _____ day of _____, 2020

NOTARY PUBLIC

**CRIMINAL CODE CERTIFICATION
AS REQUIRED BY:
STATE OF ILLINOIS CRIMINAL CODE OF 2012, 720 ILCS 5/33E-11**

I, _____ the individual whose signature appears below on this bid/contract
for _____ hereby certify that the bidding
party/contracting party is not barred from bidding on the contract as a result of a violation of either Section 33E-3 or
Section 33E-4 of 720 ILCS 5/33E-3 or 5/33E-4 of the Illinois Compiled Statutes, as amended.

By: _____
Authorized Agent of Contractor (name and title)

SUBSCRIBED AND SWORN to before
me this ____ day _____, 20__.

Notary Public

EQUAL EMPLOYMENT OPPORTUNITY

Section I. This EQUAL EMPLOYMENT OPPORTUNITY CLAUSE is required by the Illinois Human Rights Act and the Rules and Regulations of the Illinois Department of Human Rights published at 44 Illinois Administrative Code Section 750, *et seq.*

Section II. In the event of the Contractor's noncompliance with any provision of this Equal Employment Opportunity Clause, the Illinois Human Rights Act, or the Rules and Regulations of the Department of Human Rights (hereinafter referred to as the Department) the Contractor may be declared ineligible for future contracts or subcontracts with the State of Illinois or any of its political subdivisions or municipal corporations, and this Contract may be canceled or voided in whole or in part, and other sanctions or penalties may be imposed or remedies involved as provided by statute or regulation.

During the performance of this Agreement, the Contractor agrees:

A. That it will not discriminate against any employee or applicant for employment because of race, color, religion, sex, sexual orientation, national origin or ancestry, citizenship status, age, physical or mental disability unrelated to ability, military status or an unfavorable discharge from military service; and further that it will examine all job classifications to determine if minority persons or women are underutilized and will take appropriate affirmative action to rectify any such underutilization.

B. That, if it hires additional employees in order to perform this Contract, or any portion hereof, it will determine the availability (in accordance with the Department's Rules and Regulations) of minorities and women in the area(s) from which it may reasonably recruit and it will hire for each job classification for which employees are hired in such a way that minorities and women are not underutilized.

C. That, in all solicitations or advertisements for employees placed by it or on its behalf, it will state that all applicants will be afforded equal opportunity without discrimination because of race, color, religion, sex, sexual orientation, marital status, national origin or ancestry, citizenship status, age, or physical or mental handicap unrelated to ability, military status or an unfavorable discharge from military service.

D. That it will send to each labor organization or representative of workers with which it has or is bound by a collective bargaining or other agreement or understanding, a notice advising such labor organization or representative of the Vendor's obligations under the Illinois Human Rights Act and Department's Rules and Regulations. If any labor organization or representative fails or refuses to cooperate with the Contractor in its efforts to comply with the Act and Rules and Regulations, the Contractor will promptly notify the Department and the contracting agency and will recruit employees from other sources when necessary to fulfill its obligations under the Contract.

E. That it will submit reports as required by the Department's Rules and Regulations, furnish all relevant information as may from time to time be requested by the Department or the contracting agency, and in all respects comply with the Illinois Human Rights Act and Department's Rules and Regulations.

F. That it will permit access to all relevant books, records, accounts and work sites by personnel of the contracting agency and Department for purposes of investigation to ascertain compliance with the Illinois Human Rights Act and Department's Rules and Regulations.

G. That it will include verbatim or by reference the provisions of this Equal Employment Opportunity Clause in every subcontract it awards under which any portion of this Contract obligations are undertaken or assumed, so that such provisions will be binding upon such subcontractor. In the same manner as the other provisions of this Agreement, the Contractor will be liable for compliance with applicable provisions of this clause by such subcontractors; and further it will promptly notify the contracting agency and the Department in the event any subcontractor fails or refuses to comply therewith. In addition, the Contractor will not utilize any subcontractor declared by the Illinois Human Rights Department to be ineligible for contracts or subcontracts with the State of Illinois or any of its political subdivisions or municipal corporations.

ACKNOWLEDGED AND AGREED TO:

By: _____
Authorized Agent of Contractor (name and title)

DATE: _____

SEXUAL HARASSMENT POLICY

_____, having submitted a bid for _____ (Name of Contractor)
_____ to Community High School District No. 00, hereby
certifies that said contractor has a written sexual harassment policy in place in full compliance with 775 ILCS 5/2-
105 (A) (4).

By: _____
Authorized Agent of Contractor (name and title)

SUBSCRIBED AND SWORN to before
me this _____ day _____, 20____.

Notary Public

TAX CERTIFICATION

I, _____, having been first duly sworn depose and state as follows:

I, _____, am the duly authorized agent for
_____ which has submitted a proposal to Community
High School District No. 99 for

_____ and I hereby certify that
_____ is not delinquent in the payment of any tax administered by the
Illinois Department of Revenue, or if it is:

a. it is contesting its liability for the tax or the amount of tax in accordance with procedures established by the appropriate Revenue Act; or

b. it has entered into an agreement with the Department of Revenue for payment of all taxes due and is currently in compliance with that agreement.

By: _____
Authorized Agent of Contractor (name and title)

SUBSCRIBED AND SWORN to before
me this _____ day _____, 20__.

Notary Public

SUBSTANCE ABUSE PREVENTION ON PUBLIC WORKS PROJECTS

The Contractor certifies that it has in place a written program that meets or exceeds the program requirements of the Substance Abuse Prevention on Public Works Projects Act (Public Act 95-0635), and will provide a copy thereof to Community High School District No. 99 prior to commencement of work on the Project.

By: _____
Authorized Agent of Contractor (name and title)

SUBSCRIBED AND SWORN to before
me this _____ day _____, 20__.

Notary Public

**CERTIFICATE REGARDING
EMPLOYMENT OF ILLINOIS WORKERS ON PUBLIC WORKS**

_____ agrees if at the time the Agreement is executed, or if during the term of the Agreement, there is excessive unemployment in Illinois as defined in the Employment of Illinois Workers on Public Works Act, 30- ILCS 570/0/01 et seq., as two consecutive months of unemployment exceeding 5%, then _____ agrees to employ Illinois laborers in accordance with the Employment of Illinois Workers on Public Works Act. An "Illinois laborer" is defined as any person who has resided in Illinois for at least thirty (30) days and intends to become or remain an Illinois resident.

Firm: _____

By: _____
(Signature)

(Printed Name & Title)

SUBSCRIBED AND SWORN TO before me

This _____ day of _____, 2020

NOTARY PUBLIC

PREVAILING WAGE AFFIDAVIT

AFFIDAVIT: "I (we) hereby certify and affirm that if awarded a contract with Community High School District 99, we will comply fully with the "Illinois Prevailing Wage Act (Ill. Rev. Stat., 1987 Ch. 48, Sections 398 s-1-12 as amended by Public Act 86-693 and 86-799 effected January 1, 1990, and any other amendments effective thereafter)". We further understand that current prevailing wage standards are included in the Supplementary General Conditions.

The following affidavit must be signed and submitted with bidder's bid proposal. FAILURE TO DO SO MAY RESULT IN DISQUALIFICATION OF THE BIDDER.

_____, as part of its bid for the _____ work for Community High School District 99, Downers Grove, Illinois, certifies that said contractor is not barred from bidding on the aforementioned contract as a result of a violation of the Illinois Prevailing Wage Act (Ill. Rev. Stat., 1987 Ch. 48, Sections 398 s-1-12 as amended by Public Act 86-693 and 86-799 effected January 1, 1990).

Firm: _____

By: _____
(Signature)

(Printed Name & Title)

SUBSCRIBED AND SWORN TO before me

This _____ day of _____, 2020

NOTARY PUBLIC

NON-COLLUSION AFFIDAVIT

AFFIDAVIT: "I (we) hereby certify and affirm that my (our) proposal was prepared independently for this project and that it contains no fees or amounts other than that for the legitimate execution of this work as specified and that it includes no understanding or agreements in restraint of trade."

The following affidavit must be signed and submitted with bidder's bid proposal.
FAILURE TO DO SO MAY RESULT IN DISQUALIFICATION OF THE BIDDER.

_____, as a part of its bid for the _____ work for
Community High School District 99, Downers Grove, Illinois, certifies that said Contractor is not barred from bidding
on the aforementioned contract as a result of a violation of the above Non-Collusion Affidavit.

Firm: _____

By: _____
(Signature)

(Printed Name & Title)

SUBSCRIBED AND SWORN TO before me

This _____ day of _____, 2020

NOTARY PUBLIC

Criminal Background Investigations

Contractor hereby represents, warrants and certified that no officer or director thereof has any knowledge that any employee thereof has been convicted of committing or attempting to commit "Criminal Code of 1961," 720 ILCS, Sections 5/11-6 (Indecent solicitation of a child), 5/11-9 (Public indecency), 5/11-14 (Prostitution), 5/11-15 (Soliciting for a prostitute), 5/11-15.1 (Soliciting for a juvenile prostitute), 5/11-19 (Pimping), 5/11-19.1 (Juvenile pimping), 5/11-19.2 (Exploitation of a child), 5/11-20 (Obscenity), 5/11-20.1 (Sexual assault), 5/12-14 (Aggravated criminal sexual assault), 5/12-15 (Criminal sexual abuse), and 5/120-16 (Aggravated criminal sexual abuse), and/or those offenses defined in the "Cannabis Control Act," 720 ILCS, 550/1 et seq. (except the "Illinois Controlled Substances Act," 720 ILCS 570/100 et seq. and/or any offense committed or attempted in any other state or against the laws of the United States, which if committed or attempted in this State, would have been punishable as one or more of the foregoing offenses.

Contractor further agrees that it shall not employ any person who have or may have direct, daily contact with the pupils of any school in the district, and for whom a criminal background investigation has not been conducted pursuant hereto, and further represents and agrees that all applicants for any such employment shall furnish with their applications the attached written "Authorization for Criminal Background Information" form authorizing the Board of Education to request a criminal background investigation of said applicant pursuant to Section 5/10-21.9 of the School Code of Illinois and to receive criminal history record information pursuant thereto to determine if the applicant has been convicted of committing or attempting to commit any of the criminal or drug offenses enumerated above. Contractor further agrees to submit with said authorization payment for any costs and expenses associated with the criminal background investigation.

Contractor further represents, warrants, and certifies that no applicant for employment with respect to whom the criminal investigation reveals any conviction for committing and/or attempting to commit any of the above enumerated offenses shall be employed thereby in any position that involves or may involve contact with the students of the school district.

This certification is executed on the date hereinafter indicated by the designated contractor by its duly authorized officer.

Firm: _____

By: _____
(Signature)

(Printed Name & Title)

Date: _____

Criminal Background Investigation

The undersigned hereby authorizes in Board of Education of Community High School District 99, Downers Grove, Illinois, to request a criminal background investigation from the Illinois State Police, pursuant to Section 5/10-21.9 of the School Code of Illinois, 105 ILCS 5/10-21.9 and to receive criminal history record information pursuant thereto.

By: _____
(Signature of Applicant of Employee)

(Printed or Typed Name of Applicant Employee)

Date: _____

BUSINESS CLASSIFICATION

a) Business Entity (check one)

Corporation (Publicly held)* Not-for-Profit* Government Agency/Public Institution*
 Corporation (Privately held) Partnership Sole Proprietor

* If checked, do not complete section III (b) and (c) below.

b) Business Ownership (check one) If minority or woman owned, attach copy of certification evidence.

Large Business: Male Owned Woman Owned
Small Business: Male Owned Woman Owned

BUSINESS DEFINITIONS

Small Business Concern - an independently owned and operated concern certified, or certifiable, as a small business by the Federal Small Business Administration (SBA). Standard Industrial Classification (SIC) codes may be found in the Federal Acquisition Regulations, Section 19.102 or in the Federal Procurement Regulations, Section 1-1.701.

Small Disadvantaged or Minority Business Concern - a small business concern which is at least fifty-one percent (51%) owned by one or more socially and economically disadvantaged individuals or in the case of any publicly owned business, at least fifty-one percent (51%) of the stock of which is owned by such individuals; and whose management and daily business operations are controlled by one or more of such individuals. Business owners who certify that they are members of named groups (Black Americans, Hispanic Americans, Native Americans, Asian-Pacific Americans) are considered socially and economically disadvantaged.

Woman-Owned Business - a business concern that is at least fifty-one percent (51%) owned by a woman or women who also control and operate it. "Control" in this context means exercising the power to make policy decisions. "Operate" in this context means being actively involved in the day-to-day management.

c) Race/Ethnicity of Ownership (check one) based on definitions below.

Black Asian/Pacific or Asian/Indian Caucasian
 Hispanic Native American (American Indians, Eskimos, Aleuts and native Hawaiians)

ETHNIC GROUP DEFINITIONS

Black Americans: United States citizens whose origins are in any of the Black racial groups of Africa.
Hispanic Americans: United States citizens whose origins are in Mexico, Puerto Rico, Cuba, Portugal, Central or Central America.
Native Americans: United States citizens whose origins are in any of the original peoples of North America, i.e., American Indians, Eskimos, Aleuts and native Hawaiians.
Asian Pacific/Asian Indian Americans: United States citizens whose origins are in Japan, China, Korea, Taiwan, Cambodia, Laos, Vietnam, the Philippines, Samoa, Guam, the U.S. Trust Territories of the Pacific Islands, the Northern Mariana Islands, India, Pakistan, or Bangladesh.

I certify that the business classification and ethnicity indicated above reflects the true and correct status of this business in accordance with current Federal Small Business Administration criteria. I agree to inform Community High School District 99 immediately in writing of any changes to the information contained herein, including changes in ownership, controlling interest or operations. I understand that falsely certifying this information may result in suspension from participation in Community High School District 99 – South High School MFP Project.

Name: _____ Title: _____
(Print or Type)

Signature: _____ Date: _____

END OF SECTION 00301

BID DATE: February 7th, 2020 at 1:00 p.m. (CST)
(as date/time stamped by District 99's Receptionist)

BID TO: Community High School District 99
Administrative Center
6301 Springside Avenue
Downers Grove, IL 60516

RECEIVED BY:

BID FROM: _____

BID FOR: ***Bid Group #9 Bid Package #114 Landscaping for Phase B Only
Phase B***

South High School
1436 Norfolk Street
Downers Grove, IL 60516

It is required to have one original and one copy of your bid form.

THE UNDERSIGNED:

Acknowledges receipt of:

Plans and specifications for the work indicated above.

Addenda: No. _____ dated _____
No. _____ dated _____
No. _____ dated _____
No. _____ dated _____

Having examined the site of the work, and having familiarized himself or herself with local conditions affecting the cost of the work and with all requirements of the bidding documents including Instructions to Bidders, drawings, specifications and duly issued addenda as prepared by the architect, Wight & Company, hereby agrees to perform all work and furnish all labor, material and equipment specifically required of him by the bidding documents and such additional work as may be included as related requirements in other divisions or sections of the specifications, exclusive of alternate bids.

Agrees:

To furnish and install the described material and/or services for stated lump sum price.

To hold this bid open until **90** calendar days after bid opening date.

DIVISION 0 – BIDDING & CONTRACT REQUIREMENTS
SECTION 03114 - BID FORM

To accept the provisions of the General Provisions (Project Manual Division 0 – Bidding & Contracting Requirements Section 00201) and disposition of bid security.

To enter into and execute a contract with the Owner, if awarded on the basis of this bid, and in connection therewith to:

1. Furnish all bonds and insurance required by the bidding documents.
2. Accomplish the work in accordance with the contract.
3. Complete the work within the contract time herein specified.

Completion Time:

The undersigned agrees to begin construction immediately, or as directed by the Construction Manager, upon notice of contract award and to perform the following components of the work in accordance with the Construction Manager's Construction. This schedule is bound in the Project Manual. See attached scope of work in section 0300.

SCOPE OF WORK:

The work in this agreement (without additional compensation) shall include, but shall not necessarily be limited to, all skilled labor, supervision, premium time, materials, tools, equipment, plant, supplies, samples, shop drawings, design/engineering drawings, layout, transportation, supervision, contributions, insurance, taxes (if applicable), compliance with all agencies (City / Village, County, State, Federal and/or any other jurisdictional agency, as may be required) and/or all services and facilities necessary and/or required for the performance of all Work shown, detailed, and/or implied by the following documents and as defined herein.

It is understood that this Trade Contractor shall perform the Work for a complete and operational system as indicated or implied in all Contract Documents. It is recognized and understood that the documents upon which the bid is based are at a conceptual phase and this Contractor who has certain skills and judgments based upon his knowledge of techniques, procedures, systems, general state of the art of his specialty is expected to include in the scope of work, all items required in order to carry out a complete and functional system whether or not shown or described in the contract documents. This contract will be awarded on the basis of such documents with the understanding that this contractor is to furnish and install all items required for the proper completion of this work without adjustment to this contract price. No extra payments shall be made of claims entertained as a result of such items, unless it can be clearly demonstrated to be added scope to the contract and beyond the original intent of the documents.

Contractor to provide all Trade Contract work referenced in:

1. Any sheet of this bid group package including (reference Division 0 – Bidding and Contract Requirements, Section 00200 – Notice to Bidders).
2. Specification 00300 Bid Packages Scope Document.

WORK BASE BID: For providing all work including all allowances as required for the completion of the construction of the base bid project as shown on the drawings and specifications and NOT including alternate bids and/or contractor's proposed alternates and substitutes.

BASE BID

TOTAL BASE BID AMOUNT SOUTH HIGH SCHOOL MASTER FACILITY PLAN

_____ Dollars (\$ _____)

This TRADE CONTRACTOR shall include an allowance of \$10,000.00 in their base bid to account for any unforeseen conditions. Contract amounts will be adjusted by change order for amounts greater or less than the allowance. Allowance to be utilized only at the direction of Construction Manager

BONDS:

This TRADE CONTRACTOR will be required to provide a Performance and Payment Bond for their work in accordance with 00201 of the General Conditions.

Award Basis:

The project will be awarded based upon the attached Evaluation Criteria, Section 301a. Owner and Construction Manager alternate's may be considered to find the most qualified bidder if the result of combining the base bid and the selected alternate(s) is the most qualified bid, and is to the benefit of the owner.

Each of the following amounts for alternate construction includes the entire cost of such construction, except as otherwise noted. Acceptance of any or all of the alternates for inclusion in the contract is the sole prerogative of the owner.

All additional costs due to the alternates are included in the amount to be added to the base bid, so that no additional costs will be borne by the owner due to acceptance of alternates. This alternate price is not to be included in the base bid price.

Owner Requested Alternates:

Each of the following amounts for alternate construction includes the entire cost of such construction, except as otherwise noted. Acceptance of any or all of the alternates for inclusion in the contract is the sole prerogative of the owner.

All additional costs due to the alternates are included in the amount to be added to the base bid, so that no additional costs will be borne by the owner due to acceptance of alternates.

Proposed Alternates: (Contractors Proposed Alternates)

Item Specified	Proposed Alternate	Change in Bid Price
1. _____	_____	_____
2. _____	_____	_____
3. _____	_____	_____

Owner Requested Unit Prices/Allowances (as applicable to this Trade Contractor's scope of work) (additive or deductive).

This trade contractor includes _____ dumpsters for all refuse caused by this trade contractor's work in the amount of _____ Dollars (\$_____) Note: trade contractors are to include in their bid form submittal the quantity of dumpsters required to complete their work and the cost associated with same. Dumpster costs will be subtracted by change order. Dumpsters will be procured and managed by Construction Manager. Note: Dumpster use in excess of that proposed by this Trade Contractor will be adjusted by back charge.

Owner Requested Scheduling Information:

Note: The work of this Trade Contractor is to be completed in accordance with the overall project schedule as identified elsewhere in this project manual and/or as subsequently directed by Construction Manager. This Trade

Contractor shall submit a proposed submittals list/schedule/material log within five (5) calendar days of Notice To Proceed.

1. Shop drawings / Submittal for this trade contractor will be submitted within 10 calendar days of receipt of notice to proceed.

Bid Acceptance:

If written notice of the acceptance of this bid is mailed, telegraphed or delivered to the undersigned within the time noted herein, after the date of opening of bids or at any time thereafter before this bid is withdrawn, the undersigned agrees that he will execute a construction contract in accordance with the bids as accepted.

The Owner reserves the right to award the contract to its best interests, review and accept any and all value engineering alternatives, negotiate with the lowest responsible bidder, to reject any or all bids, to waive any informalities in bidding and to hold all bids for the bid guarantee period. The Owner reserves the right to award separate contracts for any of the items of work bid herein.

Bid Deposit:

The undersigned furnishes herewith, as required in the Instructions to Bidders, a bid deposit in the amount of ten percent (10%) of the amount bid in the form of Cashier's Check, or Certified Check, made payable to the Owner or Bid Bond, naming the Owner as obligee. (Bidder to check form of deposit furnished.)

It is understood and agreed that should the undersigned fail to enter into a contract with the Owner or furnish acceptable contract security within the time and in the manner herein provided, the bid deposit shall be retained by the Owner as liquidated damages and not as a forfeiture. As it is impossible to determine precisely an exact amount of damages the Owner will sustain, it is agreed that the bid deposit is a fair and equitable estimate of such damages.

REPRESENTATIONS AND CERTIFICATIONS:

The bidder makes the following representations and certifications as part of his bid on the project herein identified in the Bid Form. In the case of a joint venture bid, each party represents and certifies as to his own organization.

AVAILABILITY. The number and amount of contracts and awards pending which I am and/or will be obligated to perform, now and during the course of the project, will not interfere with or hinder the timely prosecution of my work.

SURETY. I have notified a Surety Company that I am submitting a bid for work to be performed on the project. The Surety Company has agreed to issue a performance and labor and material payment bond for my work, if my bid is accepted and the contract awarded to me.

INDEPENDENT PRICE DETERMINATION. The contract sum in this bid has been arrived at independently, without consultation, communication or agreement for the purpose of restricting competition.

PREVAILING WAGE. The contractor and each subcontractor shall pay not less than the general prevailing rate of hourly wages for work of a similar character in the locality in which the work is performed and not less than general prevailing rate of hourly wages for legal holidays and overtime work in the performance of work under this contract, as established by the Illinois Department of Labor, pursuant to an act of the General Assembly of the State of Illinois approved June 26, 1941 as amended according to Section 820 ILCS 130/1.

Pursuant to Section 820 ILCS 130/5, the contractor and each subcontractor shall keep an accurate record showing the names and occupation of all laborers, workers and mechanics employed by them, and also showing the actual hourly wages paid to each such individual, which record shall be open at all reasonable hours to inspection by the Owner, its officers and agents, and to agents of the Illinois Department of Labor.

DIVISION 0 – BIDDING & CONTRACT REQUIREMENTS
SECTION 03114 - BID FORM

The contractor and each subcontractor hereby agree, jointly and severally, to defend, indemnify and hold harmless the Owner from any and all claims, demands, liens or suits of any kind or nature whatsoever (including suits for injunctive relief) by the Illinois Department of Labor under the Illinois Prevailing Wage Act, Section 820 ILCS 130/1., or by any laborer, worker or mechanic employed by the contractor or the subcontractor who alleges that he has been paid for his services in a sum less than prevailing wage rates required by Illinois law. The Owner agrees to notify the contractor or subcontractor of the pendency of any such claim, demand, lien or suit.

DIVISION 0 – BIDDING & CONTRACT REQUIREMENTS
SECTION 03114 - BID FORM

By submitting a bid, each bidder agrees to waive any claim it has or may have against the Owner, the Architect, Engineer, Construction Manager and their respective employees, arising out of or in connection with the administration, evaluation, or recommendation of any bid; waiver of any requirements under the Bid Documents; or the Contract Document; acceptance or rejection of any bids; and award of the Contract.

Signature:

Respectfully submitted this _____ day _____, 2020

Type of Firm (Bidder to indicate)

_____ Individual

_____ Partnership

_____ Corporation

_____ Joint Venture

_____ Other

(Firm Name)

(Address)

(CORPORATE SEAL)

(Telephone Number) (FAX)

(E-mail Address)

(Bidder's Signature)

(Title)

Subscribed and sworn to me
this _____ day of _____, 2020

NOTE: All pages of this bid form must be returned with your proposal. Failure to do so shall disqualify your bid.

CERTIFICATE OF BIDDER ELIGIBILITY

720 ILCS 5/33E-11 REQUIRES THAT ALL CONTRACTORS BIDDING FOR PUBLIC AGENCIES IN THE State of Illinois certify that they are not barred from bidding on public contracts for bid rigging or bid rotation.

The following certification must be signed and submitted with bidder's bid proposal. FAILURE TO DO SO MAY RESULT IN DISQUALIFICATION OF THE BIDDER.

_____, as part of its bid for the _____ work for Community High School District 99, Downers Grove, Illinois, DuPage County, Illinois certified that said contractor is not barred from bidding on the aforementioned contract as a result of violation of either 720 ILCS 5/33E-3 or 720 ILCS 5/33-E4.

Firm: _____

By: _____
(Signature)

(Printed Name & Title)

SUBSCRIBED AND SWORN TO before me

This _____ day of _____, 2020

NOTARY PUBLIC

**CRIMINAL CODE CERTIFICATION
AS REQUIRED BY:
STATE OF ILLINOIS CRIMINAL CODE OF 2012, 720 ILCS 5/33E-11**

I, _____ the individual whose signature appears below on this bid/contract
for _____ hereby certify that the bidding
party/contracting party is not barred from bidding on the contract as a result of a violation of either Section 33E-3 or
Section 33E-4 of 720 ILCS 5/33E-3 or 5/33E-4 of the Illinois Compiled Statutes, as amended.

By: _____
Authorized Agent of Contractor (name and title)

SUBSCRIBED AND SWORN to before
me this ____ day _____, 20__.

Notary Public

EQUAL EMPLOYMENT OPPORTUNITY

Section I. This EQUAL EMPLOYMENT OPPORTUNITY CLAUSE is required by the Illinois Human Rights Act and the Rules and Regulations of the Illinois Department of Human Rights published at 44 Illinois Administrative Code Section 750, *et seq.*

Section II. In the event of the Contractor's noncompliance with any provision of this Equal Employment Opportunity Clause, the Illinois Human Rights Act, or the Rules and Regulations of the Department of Human Rights (hereinafter referred to as the Department) the Contractor may be declared ineligible for future contracts or subcontracts with the State of Illinois or any of its political subdivisions or municipal corporations, and this Contract may be canceled or voided in whole or in part, and other sanctions or penalties may be imposed or remedies involved as provided by statute or regulation.

During the performance of this Agreement, the Contractor agrees:

A. That it will not discriminate against any employee or applicant for employment because of race, color, religion, sex, sexual orientation, national origin or ancestry, citizenship status, age, physical or mental disability unrelated to ability, military status or an unfavorable discharge from military service; and further that it will examine all job classifications to determine if minority persons or women are underutilized and will take appropriate affirmative action to rectify any such underutilization.

B. That, if it hires additional employees in order to perform this Contract, or any portion hereof, it will determine the availability (in accordance with the Department's Rules and Regulations) of minorities and women in the area(s) from which it may reasonably recruit and it will hire for each job classification for which employees are hired in such a way that minorities and women are not underutilized.

C. That, in all solicitations or advertisements for employees placed by it or on its behalf, it will state that all applicants will be afforded equal opportunity without discrimination because of race, color, religion, sex, sexual orientation, marital status, national origin or ancestry, citizenship status, age, or physical or mental handicap unrelated to ability, military status or an unfavorable discharge from military service.

D. That it will send to each labor organization or representative of workers with which it has or is bound by a collective bargaining or other agreement or understanding, a notice advising such labor organization or representative of the Vendor's obligations under the Illinois Human Rights Act and Department's Rules and Regulations. If any labor organization or representative fails or refuses to cooperate with the Contractor in its efforts to comply with the Act and Rules and Regulations, the Contractor will promptly notify the Department and the contracting agency and will recruit employees from other sources when necessary to fulfill its obligations under the Contract.

E. That it will submit reports as required by the Department's Rules and Regulations, furnish all relevant information as may from time to time be requested by the Department or the contracting agency, and in all respects comply with the Illinois Human Rights Act and Department's Rules and Regulations.

F. That it will permit access to all relevant books, records, accounts and work sites by personnel of the contracting agency and Department for purposes of investigation to ascertain compliance with the Illinois Human Rights Act and Department's Rules and Regulations.

G. That it will include verbatim or by reference the provisions of this Equal Employment Opportunity Clause in every subcontract it awards under which any portion of this Contract obligations are undertaken or assumed, so that such provisions will be binding upon such subcontractor. In the same manner as the other provisions of this Agreement, the Contractor will be liable for compliance with applicable provisions of this clause by such subcontractors; and further it will promptly notify the contracting agency and the Department in the event any subcontractor fails or refuses to comply therewith. In addition, the Contractor will not utilize any subcontractor declared by the Illinois Human Rights Department to be ineligible for contracts or subcontracts with the State of Illinois or any of its political subdivisions or municipal corporations.

ACKNOWLEDGED AND AGREED TO:

By: _____
Authorized Agent of Contractor (name and title)

DATE: _____

SEXUAL HARASSMENT POLICY

_____, having submitted a bid for _____ (Name of Contractor)
_____ to Community High School District No. 00, hereby
certifies that said contractor has a written sexual harassment policy in place in full compliance with 775 ILCS 5/2-
105 (A) (4).

By: _____
Authorized Agent of Contractor (name and title)

SUBSCRIBED AND SWORN to before
me this _____ day _____, 20____.

Notary Public

TAX CERTIFICATION

I, _____, having been first duly sworn depose and state as follows:

I, _____, am the duly authorized agent for
_____ which has submitted a proposal to Community
High School District No. 99 for

_____ and I hereby certify that
_____ is not delinquent in the payment of any tax administered by the
Illinois Department of Revenue, or if it is:

a. it is contesting its liability for the tax or the amount of tax in accordance with procedures established by the appropriate Revenue Act; or

b. it has entered into an agreement with the Department of Revenue for payment of all taxes due and is currently in compliance with that agreement.

By: _____
Authorized Agent of Contractor (name and title)

SUBSCRIBED AND SWORN to before
me this _____ day _____, 20__.

Notary Public

SUBSTANCE ABUSE PREVENTION ON PUBLIC WORKS PROJECTS

The Contractor certifies that it has in place a written program that meets or exceeds the program requirements of the Substance Abuse Prevention on Public Works Projects Act (Public Act 95-0635), and will provide a copy thereof to Community High School District No. 99 prior to commencement of work on the Project.

By: _____
Authorized Agent of Contractor (name and title)

SUBSCRIBED AND SWORN to before
me this _____ day _____, 20__.

Notary Public

**CERTIFICATE REGARDING
EMPLOYMENT OF ILLINOIS WORKERS ON PUBLIC WORKS**

_____ agrees if at the time the Agreement is executed, or if during the term of the Agreement, there is excessive unemployment in Illinois as defined in the Employment of Illinois Workers on Public Works Act, 30- ILCS 570/0/01 et seq., as two consecutive months of unemployment exceeding 5%, then _____ agrees to employ Illinois laborers in accordance with the Employment of Illinois Workers on Public Works Act. An "Illinois laborer" is defined as any person who has resided in Illinois for at least thirty (30) days and intends to become or remain an Illinois resident.

Firm: _____

By: _____
(Signature)

(Printed Name & Title)

SUBSCRIBED AND SWORN TO before me

This _____ day of _____, 2020

NOTARY PUBLIC

PREVAILING WAGE AFFIDAVIT

AFFIDAVIT: "I (we) hereby certify and affirm that if awarded a contract with Community High School District 99, we will comply fully with the "Illinois Prevailing Wage Act (Ill. Rev. Stat., 1987 Ch. 48, Sections 398 s-1-12 as amended by Public Act 86-693 and 86-799 effected January 1, 1990, and any other amendments effective thereafter)". We further understand that current prevailing wage standards are included in the Supplementary General Conditions.

The following affidavit must be signed and submitted with bidder's bid proposal. FAILURE TO DO SO MAY RESULT IN DISQUALIFICATION OF THE BIDDER.

_____, as part of its bid for the _____ work for Community High School District 99, Downers Grove, Illinois, certifies that said contractor is not barred from bidding on the aforementioned contract as a result of a violation of the Illinois Prevailing Wage Act (Ill. Rev. Stat., 1987 Ch. 48, Sections 398 s-1-12 as amended by Public Act 86-693 and 86-799 effected January 1, 1990).

Firm: _____

By: _____
(Signature)

(Printed Name & Title)

SUBSCRIBED AND SWORN TO before me

This _____ day of _____, 2020

NOTARY PUBLIC

NON-COLLUSION AFFIDAVIT

AFFIDAVIT: "I (we) hereby certify and affirm that my (our) proposal was prepared independently for this project and that it contains no fees or amounts other than that for the legitimate execution of this work as specified and that it includes no understanding or agreements in restraint of trade."

The following affidavit must be signed and submitted with bidder's bid proposal.
FAILURE TO DO SO MAY RESULT IN DISQUALIFICATION OF THE BIDDER.

_____, as a part of its bid for the _____ work for
Community High School District 99, Downers Grove, Illinois, certifies that said Contractor is not barred from bidding
on the aforementioned contract as a result of a violation of the above Non-Collusion Affidavit.

Firm: _____

By: _____
(Signature)

(Printed Name & Title)

SUBSCRIBED AND SWORN TO before me

This _____ day of _____, 2020

NOTARY PUBLIC

Criminal Background Investigations

Contractor hereby represents, warrants and certified that no officer or director thereof has any knowledge that any employee thereof has been convicted of committing or attempting to commit "Criminal Code of 1961," 720 ILCS, Sections 5/11-6 (Indecent solicitation of a child), 5/11-9 (Public indecency), 5/11-14 (Prostitution), 5/11-15 (Soliciting for a prostitute), 5/11-15.1 (Soliciting for a juvenile prostitute), 5/11-19 (Pimping), 5/11-19.1 (Juvenile pimping), 5/11-19.2 (Exploitation of a child), 5/11-20 (Obscenity), 5/11-20.1 (Sexual assault), 5/12-14 (Aggravated criminal sexual assault), 5/12-15 (Criminal sexual abuse), and 5/120-16 (Aggravated criminal sexual abuse), and/or those offenses defined in the "Cannabis Control Act," 720 ILCS, 550/1 et seq. (except the "Illinois Controlled Substances Act," 720 ILCS 570/100 et seq. and/or any offense committed or attempted in any other state or against the laws of the United States, which if committed or attempted in this State, would have been punishable as one or more of the foregoing offenses.

Contractor further agrees that it shall not employ any person who have or may have direct, daily contact with the pupils of any school in the district, and for whom a criminal background investigation has not been conducted pursuant hereto, and further represents and agrees that all applicants for any such employment shall furnish with their applications the attached written "Authorization for Criminal Background Information" form authorizing the Board of Education to request a criminal background investigation of said applicant pursuant to Section 5/10-21.9 of the School Code of Illinois and to receive criminal history record information pursuant thereto to determine if the applicant has been convicted of committing or attempting to commit any of the criminal or drug offenses enumerated above. Contractor further agrees to submit with said authorization payment for any costs and expenses associated with the criminal background investigation.

Contractor further represents, warrants, and certifies that no applicant for employment with respect to whom the criminal investigation reveals any conviction for committing and/or attempting to commit any of the above enumerated offenses shall be employed thereby in any position that involves or may involve contact with the students of the school district.

This certification is executed on the date hereinafter indicated by the designated contractor by its duly authorized officer.

Firm: _____

By: _____
(Signature)

(Printed Name & Title)

Date: _____

Criminal Background Investigation

The undersigned hereby authorizes in Board of Education of Community High School District 99, Downers Grove, Illinois, to request a criminal background investigation from the Illinois State Police, pursuant to Section 5/10-21.9 of the School Code of Illinois, 105 ILCS 5/10-21.9 and to receive criminal history record information pursuant thereto.

By: _____
(Signature of Applicant of Employee)

(Printed or Typed Name of Applicant Employee)

Date: _____

BUSINESS CLASSIFICATION

a) Business Entity (check one)

Corporation (Publicly held)* Not-for-Profit* Government Agency/Public Institution*
 Corporation (Privately held) Partnership Sole Proprietor

* If checked, do not complete section III (b) and (c) below.

b) Business Ownership (check one) If minority or woman owned, attach copy of certification evidence.

Large Business: Male Owned Woman Owned
Small Business: Male Owned Woman Owned

BUSINESS DEFINITIONS

Small Business Concern - an independently owned and operated concern certified, or certifiable, as a small business by the Federal Small Business Administration (SBA). Standard Industrial Classification (SIC) codes may be found in the Federal Acquisition Regulations, Section 19.102 or in the Federal Procurement Regulations, Section 1-1.701.

Small Disadvantaged or Minority Business Concern - a small business concern which is at least fifty-one percent (51%) owned by one or more socially and economically disadvantaged individuals or in the case of any publicly owned business, at least fifty-one percent (51%) of the stock of which is owned by such individuals; and whose management and daily business operations are controlled by one or more of such individuals. Business owners who certify that they are members of named groups (Black Americans, Hispanic Americans, Native Americans, Asian-Pacific Americans) are considered socially and economically disadvantaged.

Woman-Owned Business - a business concern that is at least fifty-one percent (51%) owned by a woman or women who also control and operate it. "Control" in this context means exercising the power to make policy decisions. "Operate" in this context means being actively involved in the day-to-day management.

c) Race/Ethnicity of Ownership (check one) based on definitions below.

Black Asian/Pacific or Asian/Indian Caucasian
 Hispanic Native American (American Indians, Eskimos, Aleuts and native Hawaiians)

ETHNIC GROUP DEFINITIONS

Black Americans: United States citizens whose origins are in any of the Black racial groups of Africa.

Hispanic Americans: United States citizens whose origins are in Mexico, Puerto Rico, Cuba, Portugal, Central or Central America.

Native Americans: United States citizens whose origins are in any of the original peoples of North America, i.e., American Indians, Eskimos, Aleuts and native Hawaiians.

Asian Pacific/Asian Indian Americans: United States citizens whose origins are in Japan, China, Korea, Taiwan, Cambodia, Laos, Vietnam, the Philippines, Samoa, Guam, the U.S. Trust Territories of the Pacific Islands, the Northern Mariana Islands, India, Pakistan, or Bangladesh.

I certify that the business classification and ethnicity indicated above reflects the true and correct status of this business in accordance with current Federal Small Business Administration criteria. I agree to inform Community High School District 99 immediately in writing of any changes to the information contained herein, including changes in ownership, controlling interest or operations. I understand that falsely certifying this information may result in suspension from participation in Community High School District 99 – South High School MFP Project.

Name: _____ Title: _____
(Print or Type)

Signature: _____ Date: _____

END OF SECTION 00301

Scope – This TRADE CONTRACTOR’s scope shall include but not be limited to the scope listed below. Please see entirety of bid documents for all scope requirements.

BG9 BP105 SCOPE OF WORK FOR FLOORING FOR SOUTH HIGH SCHOOL PHASE C

1. This TRADE CONTRACTOR shall reference ALL General, Existing Architectural, Architectural Demolition, Architectural, Mechanical, Mechanical Demolition, Plumbing Demolition, Plumbing, Electrical Demolition, Electrical, and Technology Sheets included in this Bid Group 7C as they relate to Flooring. This TRADE CONTRACTOR shall read all Notes and General Notes included in the drawings as they pertain to this scope of work. This TRADE CONTRACTOR shall review the project SCHEDULE included in this project manual and provide sufficient manpower to complete this TRADE CONTRACTOR’s scope of work within the designated durations provided.

Note: This TRADE CONTRACTOR’S scope of work shall be limited to those areas as indicated by Phase C on plans. Any work shown outside of this scope area shall not be included in this TRADE CONTRACTOR’S scope of work unless otherwise noted in this document. This is Phase 3 of 3 phases of the Master Facility Plan, thus some drawings may include areas of work not to be included in this scope of work. Refer to Exhibit A for further clarification on the area considered Phase C.

2. This TRADE CONTRACTOR shall be responsible for furnishing and installing all materials, skilled and/or licensed labor, equipment, tools, etc... to complete all aspects of this TRADE CONTRACTOR’s work for flooring including all Carpet Tile, Vinyl Tile, Quartz Tile, Rubber Stair Treads, Stair Nosing, Rubber Stair Risers, Rubber Tile, Terrazzo Treads and Landings, Walk-Off Carpet, Rubber Wall Base, all associated transitions and accessories, etc. as listed in the specifications and shown on the construction documents.

NOTE: This TRADE CONTRACTOR shall NOT be responsible for furnishing and installing Quartz Tile flooring at corridor 1-351 on the first floor. This will be provided by the Phase B Flooring Contractor.

NOTE: This TRADE CONTRACTOR shall provide all base per contract documents at casework locations. The installation of base on millwork items that are installed after the flooring installation shall be included in this TRADE CONTRACTOR’s bid and no additional mobilization for this will be paid by the owner.

3. This TRADE CONTRACTOR shall be responsible for providing all transition profiles per details on A10.00 as they relate to this TRADE CONTRACTOR’s scope of work. The transitions between ceramic tile and other flooring finishes will be provided by the CERAMIC TRADE CONTRACTOR. Transitions between the Stage Flooring and other materials shall be provided by the STAGE FLOORING TRADE CONTRACTOR.
4. This TRADE CONTRACTOR shall be responsible for any and all floor expansion joint covers per contract documents as well as all floor joints FJ-1, FJ-2, FJ-3 per details on A7.50.
5. This TRADE CONTRACTOR shall be responsible for patching flooring as required to match adjacent flooring at areas shown in the contract documents, refer to keynotes on A10 series drawings for additional information. This scope shall exclude keynote F31 on A10.11C.
6. This TRADE CONTRACTOR shall be responsible for all carpet at auditorium aisles, including rubber nosing at stairs as shown in the construction documents.

003000-1

7. This TRADE CONTRACTOR shall be responsible for providing a Walk-off Carpet at the east entrance vestibule 1-412 even though drawings call out for Quartz tile.
8. This TRADE CONTRACTOR shall be responsible for furnishing and installing the precast Terrazzo Treads and Landings designated as TRZ-1 and TST-1 per the contract documents. This TRADE CONTRACTOR shall also include the black epoxy abrasive strips for the terrazzo treads as shown in A6.01.
9. This TRADE CONTRACTOR shall be responsible for all layout work, measuring and field dimensioning associated with this Trade Contractor's work. This includes any areas where there might be curved floor transitions.
10. This TRADE CONTRACTOR shall be responsible for all floor preparation required for the work of this TRADE CONTRACTOR. Start of work by this trade contractor on top of or against concrete/masonry/drywall or any other surface acknowledges this trade contractor's acceptance of quality and completeness of adjacent surface.
11. This TRADE CONTRACTOR shall be responsible for and compliant with all specified requirements including but not limited to all: Performance Requirements, Submittals, QA, Testing, Training, QC, and Extra Materials specified and pertaining to this trade contractor's work as noted in the plans and specifications.

NOTE: This TRADE CONTRACTOR shall be responsible for providing all shop drawings, submittals and mock-up's per project specifications in a timely manner.

NOTE: This TRADE CONTRACTOR shall be responsible for furnishing and delivering any and all extra materials specified to owner as listed in the specifications and shown on the construction documents properly packaged and labeled. Coordinate storage location with Construction Manager prior to delivery.

12. This TRADE CONTRACTOR shall include all testing related work including but not limited to moisture, etc... All testing and results are to be documented and transmitted within 2-working days of test completion to Construction Manager.
13. This TRADE CONTRACTOR shall be responsible for protecting any and all flooring and related materials and equipment on-site and as specified: prior to installation, during installation and/or until final acceptance by Construction Manager.
14. All materials to be staged in approved location by Construction Manager and owner. This TRADE CONTRACTOR shall be responsible for coordinating staging/storing location with Construction Manager prior to any onsite delivery.
15. This TRADE CONTRACTOR to provide sufficient equipment, material, skilled manpower, supervision and/or premium time/shift work (all without additional compensation) as may be required to complete the work of this Trade Contractor in accordance with the overall project schedule.
16. All mobilizations and demobilizations related costs of this TRADE CONTRACTOR are to be included without consideration of additional compensation.
17. All surplus (left-over) flooring materials shall be hauled off site by this TRADE CONTRACTOR. This material shall not to be placed in an on-site dumpster.

003000-2

ALLOWANCES, BOND, & ALTERNATES

1. This TRADE CONTRACTOR shall include an allowance of **\$110,000.00 in their base bid** for floor prep and leveling and moisture mitigation. Contract amounts will be adjusted by change order for amounts greater or less than the allowance. Allowance to be utilized only at the direction of Construction Manager.
2. This TRADE CONTRACTOR shall provide **Unit Pricing** / S.F. for additional Flooring Leveling, if necessary, due to unforeseen conditions. Unit Pricing shall include all labor and material. Unit Pricing to be placed in designated location on Bid Form.
3. This TRADE CONTRACTOR shall provide **Unit Pricing** / S.F. for Flooring mitigation, if necessary, due to failed alkalinity or moisture tests. Unit Pricing shall include all labor and material. Unit Pricing to be placed in designated location on Bid Form.
4. This TRADE CONTRACTOR will be required to provide a Performance and Payment Bond for their work in accordance with 002010 of the General Conditions.

ACCEPTANCE

Accepted as listed above in addition to terms and conditions of the original construction documents on which the bid was based.

Company: Wight Construction Services, Inc.
2500 North Frontage Road
Darien, IL 60561

Signed: _____
Printed Name: _____
Position: _____
Date: _____

END OF SECTION 003000 –Scope

**BG9 BP107 SCOPE OF WORK FOR ACOUSTICAL CEILINGS AND WALL PANELS - SOUTH HIGH SCHOOL
PHASE C**

Scope – This TRADE CONTRACTOR’s scope shall include but not be limited to the scope listed below. Please see entirety of bid documents for all scope requirements.

1. This TRADE CONTRACTOR shall reference ALL General, Existing Architectural, Architectural Demolition, Architectural, Mechanical, Mechanical Demolition, Plumbing Demolition, Plumbing, Electrical Demolition, Electrical, and Technology Sheets included in this Bid Group 9 as they relate to Acoustical Ceilings. This TRADE CONTRACTOR shall read all Specification Sections in this manual as well as Notes and General Notes included in the drawings as they pertain to this scope of work. This TRADE CONTRACTOR shall review the project SCHEDULE included in this project manual and provide sufficient manpower and equipment to complete this trade contractor’s scope of work within the designated durations provided.

Note: This TRADE CONTRACTOR’S scope of work shall be limited to those areas as indicated by Phase C on plans. Any work shown outside of this scope area shall not be included in this TRADE CONTRACTOR’S scope of work unless otherwise noted in this document. This is Phase 3 of 3 phases of the Master Facility Plan, thus some drawings may include areas of work not to be included in this scope of work. Refer to Exhibit A included in the bid documents for further clarification on areas considered Phase C.

2. This TRADE CONTRACTOR shall be responsible for furnishing and installing all materials, skilled and/or licensed labor, equipment, tools, etc. to complete all aspects of this TRADE CONTRACTOR’s work including ALL Suspended Acoustical Ceiling Components including: acoustical ceilings (ACT-1, ACT-2, ACT-3), metal suspension systems, perimeter suspension edge trim, metal edge moldings, shadow moldings, trim, compasso trim, axiom transitions, transition trims, hangers, tie wires, fasteners, etc. as listed in Specification Section 095113 – Acoustical Panel Ceilings and shown on the reflected ceiling plans in the drawings.

NOTE: This TRADE CONTRACTOR shall not be responsible for any gypsum board ceilings (GYP-1) as shown in the Reflected Ceiling Plans. This shall be responsibility of the Framing and Drywall Contractor.

NOTE: This TRADE CONTRACTOR shall be responsible for furnishing all axiom trims/transitions (straight and curved). This TRADE CONTRACTOR shall be responsible for installing the trims where there is a transition from ACT to ACT or at the edge of ACT systems; the METAL FRAMING AND DRYWALL TRADE CONTRACTOR shall install the transitions furnished by this TRADE CONTRACTOR between ACT and Drywall Ceilings. It is the responsibility of THIS TRADE CONTRACTOR to field measure and coordinate the height of the transitions, as well as delivering in a timely manner as to not delay the METAL FRAMING AND DRYWALL CONTRACTOR.

NOTE: This TRADE CONTRACTOR shall NOT be responsible for the perimeter trim required for the window shade pocket detail per detail 1/A3.20.

3. This TRADE CONTRACTOR shall be responsible for any modification of existing grid as called out in the bid documents to receive new ceiling or new partition walls, including but not limited to keynotes C31 on A3.11C, C29 on A3.11E, etc.

00300-1

NOTE: Additional modifications to existing grids might be required and this work will be done as T&M work at CM’s direction and covered by the contract allowance. See Allowances section for additional information.

4. This TRADE CONTRACTOR shall be responsible for providing dark acoustical ceiling tiles and grid components where indicated in the construction documents, refer to keynote C47 on A3.13F.
5. This TRADE CONTRACTOR shall be responsible for the coordination and accommodation of miscellaneous equipment and fixtures scheduled to be installed in acoustical ceilings including but not limited to grilles, diffusers, access panels, light fixtures, fire alarm fixtures, sprinklers, etc. as listed in the specifications and shown on the construction documents.
6. This TRADE CONTRACTOR shall be responsible for removing and reinstalling the Acoustical Ceiling Tiles and suspension system as needed to complete the MEP demolition and new work where existing ceiling is expected to remain. These areas include the purple areas shown in Exhibit A. This work will be done on a T&M basis at CM’s direction and will be covered by the contract allowance. This TRADE CONTRACTOR shall be responsible to have labor available to complete this work per the construction schedule.
7. This TRADE CONTRACTOR shall be responsible for furnishing and installing all materials, skilled and/or licensed labor, equipment, tools, etc. to complete all aspects of this TRADE CONTRACTOR’s work including ALL Sounds Absorbing and Diffusive Wall Panels, Felt Wall Covering, Abuse-Resistant Sound Absorbing Panels, Wood-Fiber Sound Absorbing Panels, Acoustical Panels designated as WP-1, WP-2, WP-3 and WP-4 including: acoustical wall panels, shelf angles for demountable acoustical panels, and all accessories needed for a proper installation as listed in Specification Section 097723 – Fabric Wrapped Panels, 098413 Sound Absorbing and Diffusing Wall Panels, 098415 Felt Wall Covering, 098416 Abuse-Resistant Sound Absorbing Panels, 098443 Wood-Fiber Sound Absorbing Panels and shown on the reflected ceiling plans in the drawings.

NOTE: This TRADE CONTRACTOR shall be responsible for furnishing and installing the Unistrut over wood blocking and shelf angles as shown in the construction documents to be installed between/around this TRADE CONTRACTOR’s acoustic wall panels (for example, refer to elevation 1 on A7.19).

8. This TRADE CONTRACTOR shall NOT be responsible for furnishing or installing the Acoustical Panels shown in the construction documents as provided by the Rigging Contractor.
9. This TRADE CONTRACTOR shall be responsible of providing mockups as defined/ detailed in the specifications.
10. This TRADE CONTRACTOR shall be responsible for any and all final adjustments to the suspension system for final light fixture and sprinkler head location and positioning.
11. This TRADE CONTRACTOR shall provide all clip hangers, angles, and miscellaneous metal of any nature, which is required for work covered by this Contract.
12. This TRADE CONTRACTOR shall be responsible for protecting any and all Acoustical Ceilings related materials and equipment on-site and as specified: prior to installation, during installation and/or until final acceptance by Construction Manager. Refer to specifications for further detail.

ALLOWANCES, BOND, & ALTERNATES

- 13. This TRADE CONTRACTOR shall include an allowance of **\$70,000.00 in their base bid** to account for any unforeseen conditions. Contract amounts will be adjusted by change order for amounts greater or less than the allowance. Allowance to be utilized only at the direction of Construction Manager.
- 14. This TRADE CONTRACTOR will be required to provide a Performance and Payment Bond for their work in accordance with 002010 of the General Conditions.

ACCEPTANCE

Accepted as listed above in addition to terms and conditions of the original construction documents on which the bid was based.

Company: Wight Construction Services, Inc.
2500 North Frontage Road
Darien, IL 60561

Signed: _____
Printed Name: _____
Position: _____
Date: _____

END OF SECTION 00300 –Scope

BG9 BP109 PHASE C–SCOPE OF WORK FOR THEATER SHELLS SOUTH HIGH SCHOOL

Scope – This TRADE CONTRACTOR’s scope shall include but not be limited to the scope listed below. Please see entirety of bid documents for all scope requirements.

1. This TRADE CONTRACTOR shall reference ALL Drawings and Specs in this Bid Group 8 as they relate to Theater SHELLS. This TRADE CONTRACTOR shall read all Specification Sections in this manual as well as Notes and General Notes included in the drawings as they pertain to this scope of work. This TRADE CONTRACTOR shall review the project SCHEDULE included in this project manual and provide sufficient manpower and equipment to complete this TRADE CONTRACTOR’s scope of work within the designated durations provided.
2. This TRADE CONTRACTOR shall be responsible for furnishing and installing all materials, providing skilled and/or licensed labor, equipment, tools, etc... to complete all aspects of this trade contractor’s work including but not necessarily limited to: Acoustic Orchestra Shell Enclosure Tower Units, Ceiling Panels, Transporter Devices, and Integral Lighting and Electrical Distribution as shown in the bid documents, TO series drawings and specification section 116113 ACOUSTIC ORCHESTRA ENCLOSURE.

Note: This TRADE CONTRACTOR shall be responsible for reviewing all drawings, notes, details, etc. as they relate to the Orchestra Shell Enclosure.

3. This TRADE CONTRACTOR shall be responsible for any and all coordination required between this TRADE CONTRACTOR and other TRADE CONTRACTORS (i.e. Rigging, Electrical, etc.) to furnish a functioning system.
4. This TRADE CONTRACTOR is responsible to provide all ladders, scaffolding, cranes, hoisting, lifts, rigging etc... necessary to complete work in accordance with project schedule. This TRADE CONTRACTOR shall be responsible for any bracing and shoring required during installation as well.
5. This TRADE CONTRACTOR shall be responsible for all shop drawings and calculations, and submittals.
6. This TRADE CONTRACTOR shall be responsible for the installation of all supplementary structural supports as required to complete this scope of work, including all cutting, drilling, tapping, welding, ancillary hardware, shackles, turnbuckles, wire, etc..
7. This TRADE CONTRACTOR shall be responsible for protecting any and all Theatre Shells related materials on-site: prior to installation, during installation and/or until final acceptance by Construction Manager.
8. This TRADE CONTRACTOR shall be responsible for the aiming of the integral light fixtures in the orchestra shell enclosure per specifications.
9. This TRADE CONTRACTOR shall be responsible for and compliant with all specified requirements including but not limited to all: Performance Requirements, Submittals, QA, Testing, Training, QC, and Extra Materials specified and pertaining to this trade contractor’s work as noted in the plans and specifications.

00300-1

10. This TRADE CONTRACTOR shall be responsible to provide its own project layout according to the drawings, considering the benchmark locations and elevations that will be given by the Construction Manager.

ALLOWANCES, BOND, & ALTERNATES

11. This TRADE CONTRACTOR shall include an allowance of **\$5,000.00 in their base bid** to account for any unforeseen conditions. Contract amounts will be adjusted by change order for amounts greater or less than the allowance. Allowance to be utilized only at the direction of Construction Manager.
12. This TRADE CONTRACTOR will be required to provide a Performance and Payment Bond for their work in accordance with 00201 of the General Conditions.

ACCEPTANCE

Accepted as listed above in addition to terms and conditions of the original construction documents on which the bid was based.

Company: Wight Construction Services, Inc.
2500 North Frontage Road
Darien, IL 60561

Signed: _____

Printed Name: _____

Position: _____

Date: _____

END OF SECTION 00300 –Scope

00300-2

BG9 BP110 PHASE C–SCOPE OF WORK FOR THEATER PLATFORMS -AUDITORIUM AREA – SOUTH HIGH SCHOOL

Scope – This TRADE CONTRACTOR’s scope shall include but not be limited to the scope listed below. Please see entirety of bid documents for all scope requirements.

1. This TRADE CONTRACTOR shall reference ALL Drawings and Specs in this Bid Group 9 as they relate to Theater PLATFORMS. This TRADE CONTRACTOR shall read all Specification Sections in this manual as well as Notes and General Notes included in the drawings as they pertain to this scope of work. This TRADE CONTRACTOR shall review the project SCHEDULE included in this project manual and provide sufficient manpower and equipment to complete this TRADE CONTRACTOR’s scope of work within the designated durations provided.
2. This TRADE CONTRACTOR shall be responsible for furnishing and installing all materials, providing skilled and/or licensed labor, equipment, tools, etc... to complete all aspects of this trade contractor’s work including but not necessarily limited to: **Stage Platform Systems** as shown in the bid documents, including TP Series Drawings and specification section 116223 STAGE PLATFORM SYSTEMS.

Note: This TRADE CONTRACTOR shall be responsible for reviewing all drawings, notes, details, etc. as they relate to the Stage Platform Systems.

3. This TRADE CONTRACTOR shall be responsible for furnishing and installing all Studio Theatre Audience Seating Platform Systems, Orchestra Pit Filler Platform System and Platform System Storage Carts as shown in the bid documents.
4. This TRADE CONTRACTOR shall include all items related to the Audience Seating Platforms including but not limited to: platform supports, closure panels, finished hardboard, aluminum frame edge protection, step lighting, aisle lighting, associated transformers, cables, seating platform guardrails, etc.

NOTE: Quantity of platforms included shall be enough to accommodate ALL different layouts shown in the bid documents.

5. This TRADE Contractor shall include all items related to the Orchestra Pit Filler Platforms including but not limited to removable ledger angles and clamps, cable pass-through floor panels, sound absorbing insulation, storage carts, etc.

NOTE: The Orchestra Pit Filler Platforms shall be finished to match the stage flooring provided by others.

6. This TRADE CONTRACTOR is responsible to provide all ladders, scaffolding, cranes, hoisting, lifts, rigging etc... necessary to complete work in accordance with project schedule. This TRADE CONTRACTOR shall be responsible for any bracing and shoring required during installation as well.
7. This TRADE CONTRACTOR shall be responsible for all shop drawings and calculations, and submittals.

00300-1

8. This TRADE CONTRACTOR shall be responsible for the installation of all supplementary structural supports as required to complete this scope of work, including all cutting, drilling, tapping, welding, ancillary hardware, shackles, turnbuckles, wire, etc..
9. This TRADE CONTRACTOR shall be responsible for protecting any and all Stage Platforms related materials on-site: prior to installation, during installation and/or until final acceptance by Construction Manager.
10. This TRADE CONTRACTOR shall be responsible to coordinate with electrical, structural steel, and theater contractors and consultants for proper installation and operation of this scope of work.
11. This TRADE CONTRACTOR shall be responsible for and compliant with all specified requirements including but not limited to all: Performance Requirements, Submittals, QA, Testing, Training, QC, and Extra Materials specified and pertaining to this trade contractor’s work as noted in the plans and specifications.
12. This TRADE CONTRACTOR shall be responsible to provide its own project layout according to the drawings, considering the benchmark locations and elevations that will be given by the Construction Manager.

ALLOWANCES, BOND, & ALTERNATES

13. This TRADE CONTRACTOR shall include an allowance of **\$5,000.00 in their base bid** to account for any unforeseen conditions. Contract amounts will be adjusted by change order for amounts greater or less than the allowance. Allowance to be utilized only at the direction of Construction Manager.
14. This TRADE CONTRACTOR will be required to provide a Performance and Payment Bond for their work in accordance with 00201 of the General Conditions.
15. This TRADE CONTRACTOR shall provide an **Alternate No. 8.2 PLATFORMING ADDITIVE ALTERNATE** and fill this in the appropriate spot on the bid form.

ACCEPTANCE

Accepted as listed above in addition to terms and conditions of the original construction documents on which the bid was based.

Company: Wight Construction Services, Inc.
2500 North Frontage Road
Darien, IL 60561

Signed: _____

Printed Name: _____

Position: _____

Date: _____

00300-2

END OF SECTION 00300 –Scope

**BG9 BP111 PHASE C–SCOPE OF WORK FOR THEATER RIGGING AND CURTAINS -AUDITORIUM AREA –
SOUTH HIGH SCHOOL**

**Scope – This TRADE CONTRACTOR’s scope shall include but not be limited to the scope listed below.
Please see entirety of bid documents for all scope requirements.**

1. This TRADE CONTRACTOR shall reference ALL Drawings and Specs in this Bid Group 9 as they relate to Theater Rigging. This TRADE CONTRACTOR shall read all Specification Sections in this manual as well as Notes and General Notes included in the drawings as they pertain to this scope of work. This TRADE CONTRACTOR shall review the project SCHEDULE included in this project manual and provide sufficient manpower and equipment to complete this TRADE CONTRACTOR’s scope of work within the designated durations provided.
2. This TRADE CONTRACTOR shall be responsible for furnishing and installing all materials, providing skilled and/or licensed labor, equipment, tools, etc... to complete all aspects of this trade contractor’s work including but not necessarily limited to: **Stage Edge Rail System, Stage Rigging Systems, Motorized Acoustical Panels, and Theater Curtains, Borders, Legs, and Tracks. Refer to specifications and contract documents for more information.**

Note: This TRADE CONTRACTOR shall be responsible for reviewing all drawings, notes, details, etc. as they relate to the Theatre Rigging Systems.

3. This TRADE CONTRACTOR shall be responsible for furnishing and installing all items associated to the Stage Edge Rail including stanchions, safety caps, receiver cups, synthetic mesh net panels, hardware, removable floor plugs, system component storage carts, etc.

NOTE: This TRADE CONTRACTOR shall be responsible for coordinating with the Stage Flooring Contractor for requirements to install the Stage Edge Rail. Any modifications required by this TRADE CONTRACTOR to the stage flooring to install its scope of work shall be included in this TRADE CONTRACTOR’s scope at no additional cost.

4. This TRADE CONTRACTOR shall be responsible for all Theatre Rigging components including but not limited to: Manually Operated Counterweight Rigging Linesets, Motorized Rigging Linesets, Motorized Proscenium Fire Safety Curtain, Manually Operated Acoustic Curtains and Panels, Motorized Acoustic Curtains, Stage Masking Curtains and Tracks, Rigging Accessories, and Personnel Lifts and Ladders as shown in the bid documents. Refer to specification section 116133 for additional information.
5. This TRADE CONTRACTOR shall be responsible for furnishing and installing all Motorized Acoustical Panels, Theatre Curtains, associated borders, legs, tracks, etc.

NOTE: This TRADE CONTRACTOR shall be responsible for the motorized window shades per keynote C23 as shown on A3.11F for the Studio Theatre.

6. This TRADE CONTRACTOR shall be responsible for the delegated design of all items as specified in the bid documents. Any supplementary steel required for a proper installation of this TRADE CONTRACTOR’s scope of work shall be included at no additional cost. All attachments,

00300-1

anchorages, connections, and miscellaneous steel additions to accommodate pulleys, blocks, etc., shall be designed, supplied, and installed by this TRADE CONTRACTOR.

7. This TRADE CONTRACTOR is responsible to provide all ladders, scaffolding, cranes, hoisting, lifts, rigging etc... necessary to complete work in accordance with project schedule. This TRADE CONTRACTOR shall be responsible for any bracing and shoring required during installation as well.
8. This TRADE CONTRACTOR shall be responsible for all shop drawings and calculations, and submittals.
9. This TRADE CONTRACTOR shall be responsible for the installation of all supplementary structural supports as required to complete this scope of work, including all cutting, drilling, tapping, welding, ancillary hardware, shackles, turnbuckles, wire, etc..
10. This TRADE CONTRACTOR shall be responsible for all hardware associated for this scope of work including but not limited to all pulleys, carriers, blocks, clamps, brackets, pipes, battens, rods,
11. This TRADE CONTRACTOR shall be responsible for all motors and cables as necessary to furnish and install a functional and complete Theatre Rigging system. It is responsibility of this TRADE CONTRACTOR to coordinate electrical requirements with the ELECTRICAL CONTRACTOR in a timely manner.
12. This TRADE CONTRACTOR shall be responsible for protecting any and all rigging related materials on-site: prior to installation, during installation and/or until final acceptance by Construction Manager.
13. This TRADE CONTRACTOR shall be responsible to coordinate with electrical, structural steel, stage lighting, and theater contractors and consultants for proper installation and operation of this scope of work.
14. This TRADE CONTRACTOR shall be responsible for and compliant with all specified requirements including but not limited to all: Performance Requirements, Submittals, QA, Testing, Training, QC, and Extra Materials specified and pertaining to this trade contractor's work as noted in the plans and specifications.
15. This TRADE CONTRACTOR shall be responsible to provide its own project layout according to the drawings, considering the benchmark locations and elevations that will be given by the Construction Manager.
16. All electrical conduit, wiring, boxes, and low voltage will be by OTHERS. However, direct coordination with this TRADE CONTRACTOR will be required.

ALLOWANCES, BOND, & ALTERNATES

17. This TRADE CONTRACTOR **shall include an allowance of \$10,000.00 in their base bid** to account for any unforeseen conditions. Contract amounts will be adjusted by change order for amounts greater or less than the allowance. Allowance to be utilized only at the direction of Construction Manager.

00300-2

- 18. This TRADE CONTRACTOR will be required to provide a Performance and Payment Bond for their work in accordance with 00201 of the General Conditions.
- 19. This TRADE CONTRACTOR shall provide an **Alternate No. 8.4 STAGE RIGGING DEDUCTIVE ALTERNATE** and fill this in the appropriate spot on the bid form.
- 20. **Alternate 2:** This TRADE CONTRACTOR shall provide an alternate price for furnishing and installing the box boom lighting positions and all associated steel for the auditorium.
- 21. **Alternate 3:** This TRADE CONTRACTOR shall provide an alternate price for furnishing and installing the pipe grid system as shown on A3.11 for the Theatre Classroom.

ACCEPTANCE

Accepted as listed above in addition to terms and conditions of the original construction documents on which the bid was based.

Company: Wight Construction Services, Inc.
 2500 North Frontage Road
 Darien, IL 60561

Signed: _____
Printed Name: _____
Position: _____
Date: _____

END OF SECTION 00300 –Scope

Scope – This TRADE CONTRACTOR’s scope shall include but not be limited to the scope listed below. Please see entirety of bid documents for all scope requirements.

BG9 BP114 SCOPE OF WORK FOR LANDSCAPING SOUTH HIGH SCHOOL – PHASE B ONLY

1. This TRADE CONTRACTOR shall reference ALL Landscaping Sheets included in this Bid Group 9 as they relate to this scope of work. This TRADE CONTRACTOR shall read all Notes and General Notes included in the drawings as they pertain to this scope of work. This TRADE CONTRACTOR shall review the project SCHEDULE included in this project manual and provide sufficient manpower to complete this TRADE CONTRACTOR’s scope of work within the designated durations provided.

NOTE: All other bid packages being bid out are for Phase C; however, this bid package is intended to cover the scope of work needed for Phase B ONLY. The timing for Phase B Landscaping is September 2020. Refer to Landscaping drawings and specification issued in Addendum 1 for extents of scope.

2. This TRADE CONTRACTOR shall be responsible for furnishing and installing all materials, skilled and/or licensed labor, equipment, tools, etc... to complete all aspects of this trade contractor’s work including: Site Restoration, Turfs and Grasses, Shrubs, Perennials, Top Soils, Sod, Exterior Plants and Trees, Mulch, Topsoil Final Trimming, etc. 329100-Soil Landscape Bed Preparation, 329200-Lawns and Grasses, 329300-Woody Herbaceous Plant Installation, and etc. as listed in the Specifications and shown on the drawings.
3. This TRADE CONTRACTOR shall be responsible for furnishing and **all** fine grading of topsoil that will be left at (+/- 0.1 foot).
4. This TRADE CONTRACTOR shall be responsible for the furnish and install of the Site Restoration (all areas affected by construction activities), the Turf & Grasses, Sod, Exterior Plants & Trees, etc... as shown and detailed on both the Civil and Landscape Drawings. All work to include the furnish, install, maintenance and subsequent removal of Erosion Control Measures shown in relation to this scope.

NOTE: This TRADE CONTRACTOR shall be responsible for all “Landscape Notes” and “Legends” as established on Drawings L1.01.

5. This TRADE CONTRACTOR shall be responsible to provide and install all trees, shrubs, perennials / ground covers, grasses and vines as established per the Plant List on the drawings and specs.
6. This TRADE CONTRACTOR shall be responsible to remove, salvage, store and relocate the existing memorial garden stones, pavers, etc. The existing memorial garden is located on the west entrance of the building. The new memorial garden will be located in the east entrance of the building. Removal/Salvage of existing items shall be completed after 4/20/20 and before 4/27/20. The installation of the new memorial garden shall be done in 2021. The storage and protection of these items offsite is responsibility of this TRADE CONTRACTOR.
7. This TRADE CONTRACTOR shall be responsible for and compliant with all specified requirements including but not limited to all: Performance Requirements, Submittals, QA, Testing, Training, QC, as specified and pertaining to this trade contractor’s work as noted in the plans and specifications.

003000-1

NOTE: This TRADE CONTRACTOR shall be responsible for providing all shop drawings, submittals and samples per project specifications in a timely manner.

8. This TRADE CONTRACTOR to provide sufficient equipment, material, skilled manpower, supervision and/or premium time/shift work (all without additional compensation) as may be required to complete the work of this Trade Contractor in accordance with the overall project schedule.
9. This TRADE CONTRACTOR is responsible to provide all ladders, scaffolding, hoisting, lifts, etc. necessary to complete work in accordance with project schedule.
10. All mobilizations and demobilizations related costs of this TRADE CONTRACTOR are to be included without consideration of additional compensation.

ALLOWANCES, BOND, & ALTERNATES

1. This TRADE CONTRACTOR **shall include an allowance of \$10,000.00 in their base bid** to account for any unforeseen conditions. Contract amounts will be adjusted by change order for amounts greater or less than the allowance. Allowance to be utilized only at the direction of Construction Manager.
2. This TRADE CONTRACTOR will be required to provide a Performance and Payment Bond for their work in accordance with 00201 of the General Conditions.

ACCEPTANCE

Accepted as listed above in addition to terms and conditions of the original construction documents on which the bid was based.

Company: Wight Construction Services, Inc.
2500 North Frontage Road
Darien, IL 60561

Signed: _____

Printed Name: _____

Position: _____

Date: _____

END OF SECTION 003000 –Scope

S:\Dorien\Downers Grove SD99\5274-42 CHSD99 Improvements\01\DWG\CD\5274-42_L1.01 LANDSCAPE PLAN SOUTH.dwg Iremitz Aug 05, 2019 10:40:42 am
 Wight © Copyright 2019. All rights reserved. No part of these documents may be reproduced, stored, or transmitted in any form or by any means, electronic, mechanical, photocopying, recording or otherwise, without the prior written consent of Wight.

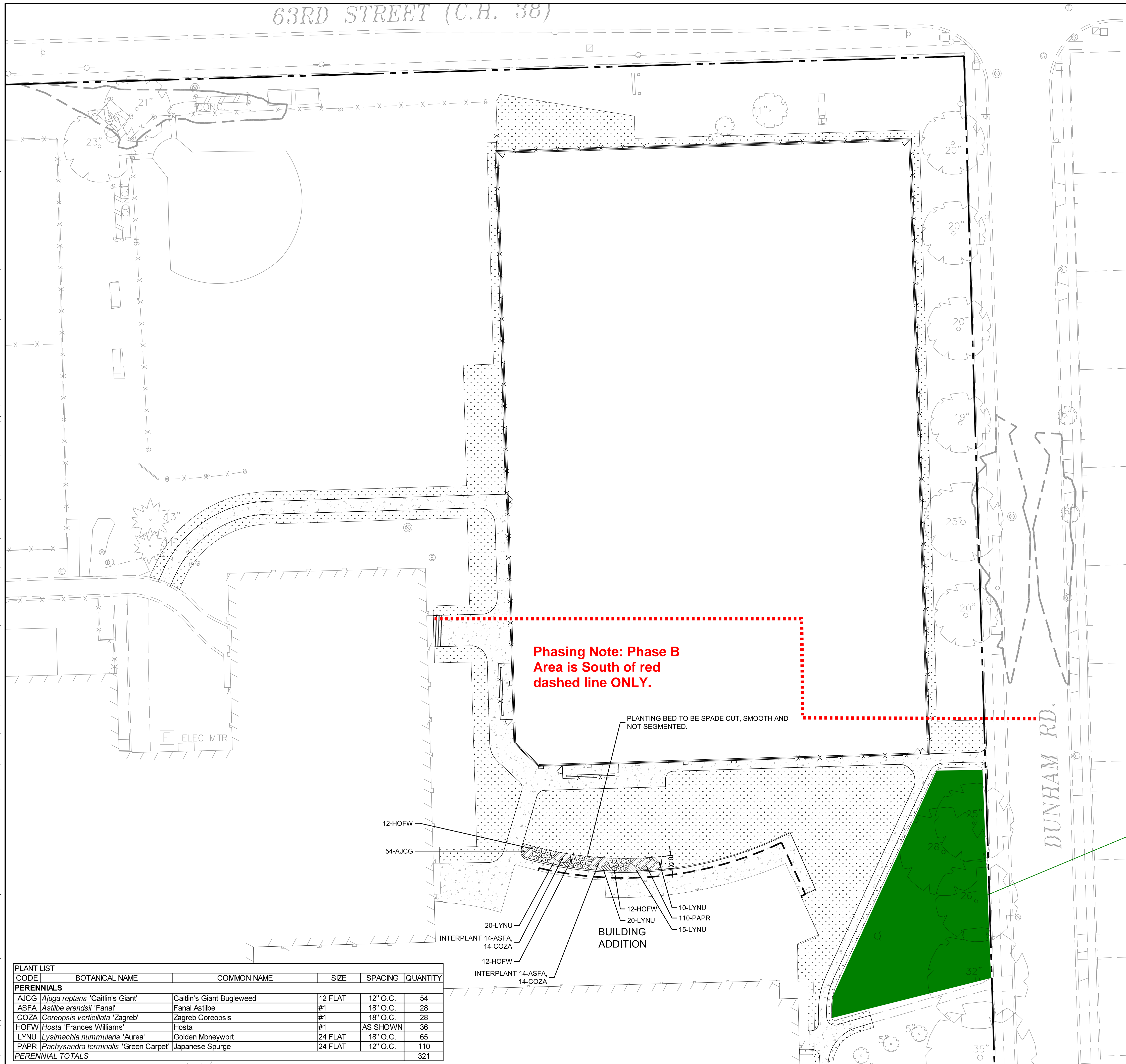

LEGEND

- SOD
- PERENNIALS
- SHADE TREE
- LARGE SHRUB

- LANDSCAPE NOTES**
- SOD LIMIT LINE IS APPROXIMATE. RESTORE TO LIMITS OF DISTURBANCE. ALL AREAS DISTURBED BY CONSTRUCTION SHALL BE RESTORED WITH TOPSOIL (MIN. 6" DEPTH), FERTILIZER, AND SOD AS SHOWN.
 - ALL AREAS DISTURBED BY CONSTRUCTION IN THE R.O.W. SHALL BE RESTORED WITH TOPSOIL (MIN. 6" DEPTH) AND KENTUCKY BLUEGRASS SOD.
 - CONTRACTOR RESPONSIBLE TO RESTORE ALL AREAS DISTURBED BY CONSTRUCTION, OUTSIDE SCOPE LIMIT, TO EXISTING CONDITION.
 - ALL PROPOSED PLANTING BED AREAS DISTURBED BY CONSTRUCTION SHALL BE RESTORED WITH TOPSOIL (MIN. 10" DEPTH) PRIOR TO PERENNIAL AND SHRUB INSTALLATION.
 - THE CONTRACTOR SHALL PROTECT ANY AND ALL TREES NOT SHOWN ON THE PLANS TO BE SAVED FROM DAMAGE DUE TO HIS OPERATIONS. CONTRACTOR SHALL INSTALL TREE PROTECTION FENCING AS SHOWN ON PLANS AND DETAILS PRIOR TO BEGINNING WORK.
 - THE CONTRACTOR WILL MAKE NO SUBSTITUTIONS WITHOUT PRIOR WRITTEN CONSENT BY THE LANDSCAPE ARCHITECT. THE CONTRACTOR WILL SUBMIT ANY SUBSTITUTIONS IN WRITING TO THE LANDSCAPE ARCHITECT.
 - ALL PLANTING TECHNIQUES AND METHODS SHALL BE CONSISTENT WITH THE LATEST EDITION OF "AMERICAN STANDARD FOR NURSERY STOCK" AND AS DETAILED ON THESE DRAWINGS. DISCREPANCIES SHALL BE REPORTED IMMEDIATELY TO THE LANDSCAPE ARCHITECT.
 - ALL PLANTING BEDS WILL RECEIVE 3" PREMIUM DOUBLE SHREDDED HARDWOOD BARK. GROUNDCOVERS SHALL RECEIVE 1-1/2" CAREFULLY PLACED AROUND BASE OF PLANT.
 - TREES PLACED IN TURF AREAS WILL HAVE 6" DIA. MULCH RING WITH 3" DEEP SPADE CUT EDGE.
 - ALL BEDLINES SHALL BE SPADE CUT TO A MIN. DEPTH OF 3". CURVED BEDLINES TO BE SMOOTH AND NOT SEGMENTED.
 - EXISTING TURF IN PROPOSED PLANTING AREAS SHALL BE STRIPPED AND REMOVED.
 - ALL PERENNIAL & SHRUB BEDS TO HAVE AMENDED TOPSOIL. 2" MINIMUM ORGANIC MATTER SHALL BE TILLED INTO THE TOP 10" OF TOPSOIL. THOROUGHLY TILL TO BREAK UP CLUMPS AND SPREAD EVENLY OVER SURFACE.
 - TREES SHALL BE INSTALLED A MINIMUM OF 10' HORIZONTALLY FROM NEAREST LIGHT POLE.
 - TREES SHALL BE INSTALLED A MINIMUM OF 5' HORIZONTALLY FROM UNDERGROUND ELECTRICAL FEEDERS, SANITARY SEWERS, SANITARY SERVICES, WATER MAINS, AND WATER SERVICES.
 - TREES SHALL BE INSTALLED A MINIMUM OF 10' HORIZONTALLY FROM UTILITY STRUCTURES AND APPURTENANCES, INCLUDING, BUT NOT LIMITED TO MANHOLES, VALVE VAULTS, VALVE BOXES, AND FIRE HYDRANTS.
 - ANY AREA COMPACTED BY CONSTRUCTION TRAFFIC SHALL BE TILLED OR RESTORED TO ALLOW FOR SUITABLE PLANTING CONDITIONS.
 - THE CROWNS AND ROOTS OF TREES WHICH ARE TO BE PRESERVED IN THE PROJECT AREA, BUT WHICH COULD BE NEGATIVELY AFFECTED DURING THE CONSTRUCTION PROCESS, SHALL BE PRUNED BY A QUALIFIED ARBORIST ACCORDING TO THE TREE PRUNING STANDARDS SET BY ANSI Z100 CODE.

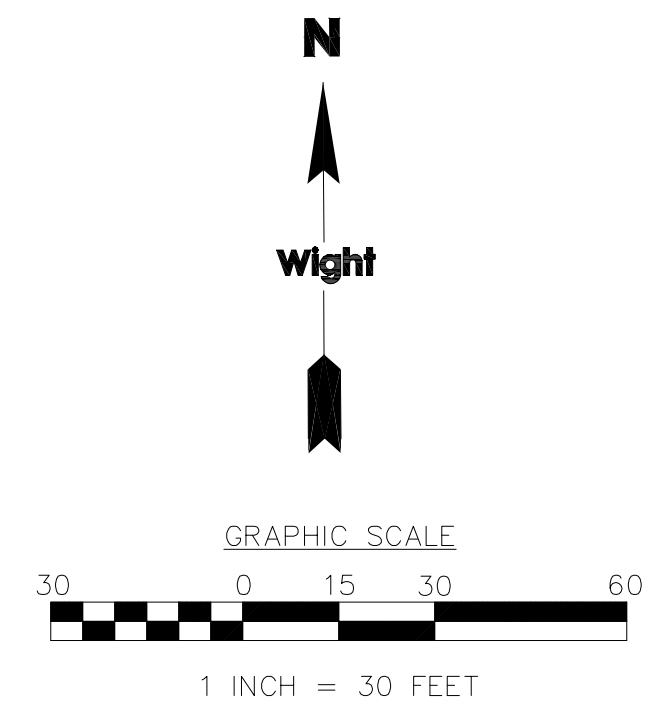

Phasing Note: Phase B Area is South of red dashed line ONLY.

This area needs to be considered for restoration. Landscaping Contractor shall be responsible for installing green seed blanket in this area.

PLANT LIST

CODE	BOTANICAL NAME	COMMON NAME	SIZE	SPACING	QUANTITY
PERENNIALS					
AJCG	<i>Ajuga reptans</i> 'Caitlin's Giant'	Caitlin's Giant Bugleweed	12 FLAT	12" O.C.	54
ASFA	<i>Astilbe arendsii</i> 'Fanal'	Fanal Astilbe	#1	18" O.C.	28
COZA	<i>Coreopsis verticillata</i> 'Zagreb'	Zagreb Coreopsis	#1	18" O.C.	28
HOFW	<i>Hosta</i> 'Frances Williams'	Hosta	#1	AS SHOWN	36
LYNU	<i>Lysimachia nummularia</i> 'Aurea'	Golden Moneywort	24 FLAT	18" O.C.	65
PAPR	<i>Pachysandra terminalis</i> 'Green Carpet'	Japanese Spurge	24 FLAT	12" O.C.	110
PERENNIAL TOTALS					321



Wight & Company
 wightco.com
 2500 North Frontage Road
 Darien, IL 60561
 P 630.969.7000
 F 630.969.7979

REV	DESCRIPTION	DATE
	ISSUED FOR CONSTRUCTION-PHASE B	07.29.2019
19	ISSUED FOR DOC MOD 008	06.14.2019
	ISSUED FOR BID GROUP 7 - PHASE B	06.07.2019
14	ISSUED FOR ADDENDUM 2 - BG6	06.05.2019
15	ISSUED FOR DOC MOD 005	06.03.2019
13	ISSUED FOR DOC MOD 004	05.16.2019
	FINAL PERMIT SUBMITTAL	05.13.2019
	ISSUED FOR BID - BID GROUP 6	05.10.2019
	ISSUED FOR BID - BID GROUP 5	05.10.2019
	ISSUED FOR CONSTRUCTION-PHASE A	05.08.2019

COMMUNITY SCHOOL DISTRICT 99 - MFP IMPLEMENTATION SOUTH HIGH SCHOOL
 1436 NORFOLK STREET
 DOWNERS GROVE, IL 60516

LANDSCAPE PLAN SOUTH

Project Number:
 5274-02
 Drawn By:
 LR
 Sheet:

L1.01

S:\Darien\Downers Grove SD99\5274-42 CHSD99 Improvements\01\DWG\CD\5274-42_L2.00 LANDSCAPE DETAILS SOUTH.dwg Iremitz Aug 05, 2019 10:45:05 am
 Wight © Copyright 2019. All rights reserved. No part of these documents may be reproduced, stored, or transmitted in any form or by any means, electronic, mechanical, photocopying, recording or otherwise, without the prior written consent of Wight.

1 TREE PLANTING
 SCALE: 1/2"=1'-0"

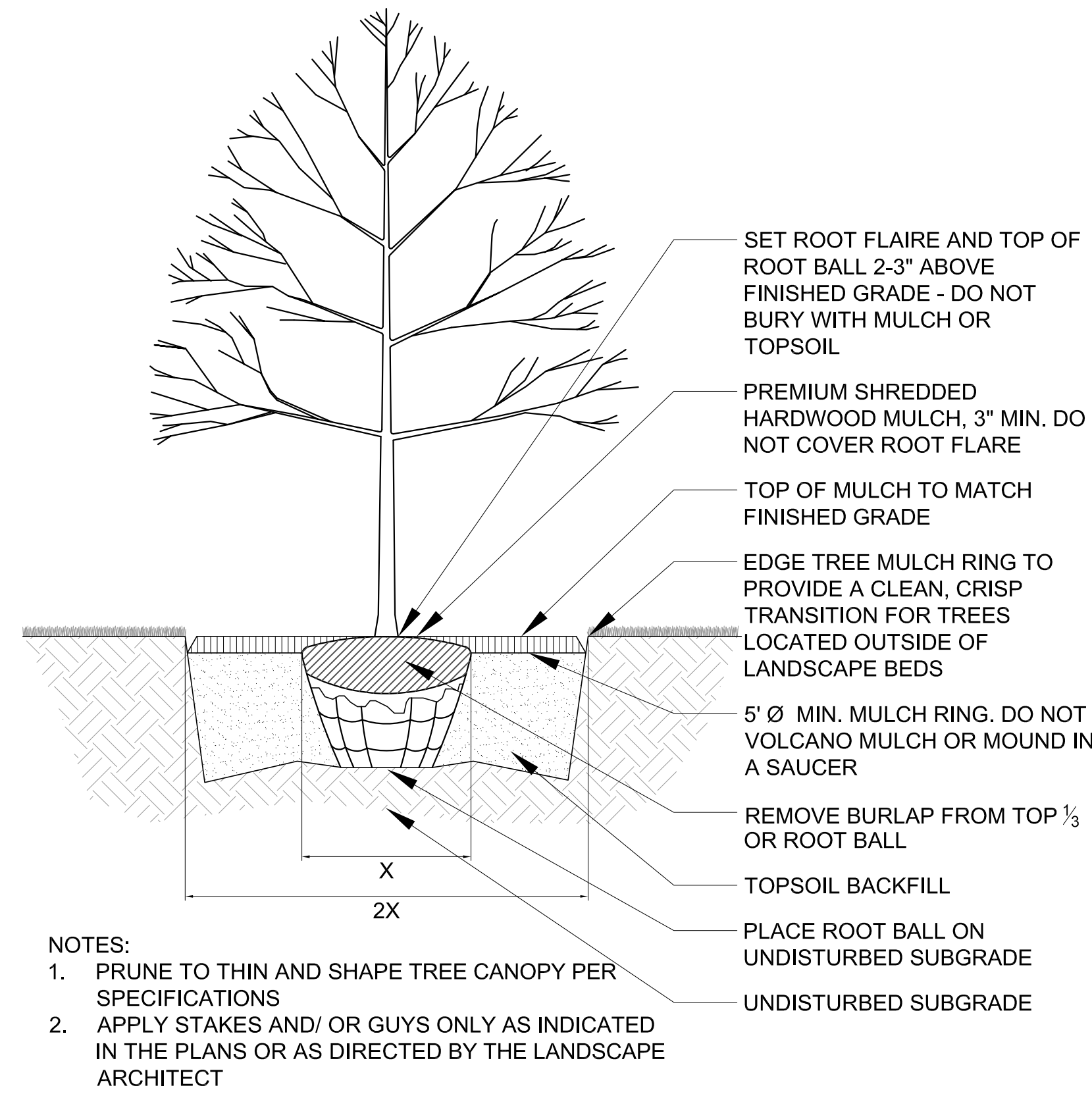

2 BACKLESS BENCH, SURFACE MOUNT 71"
 SCALE: NTS

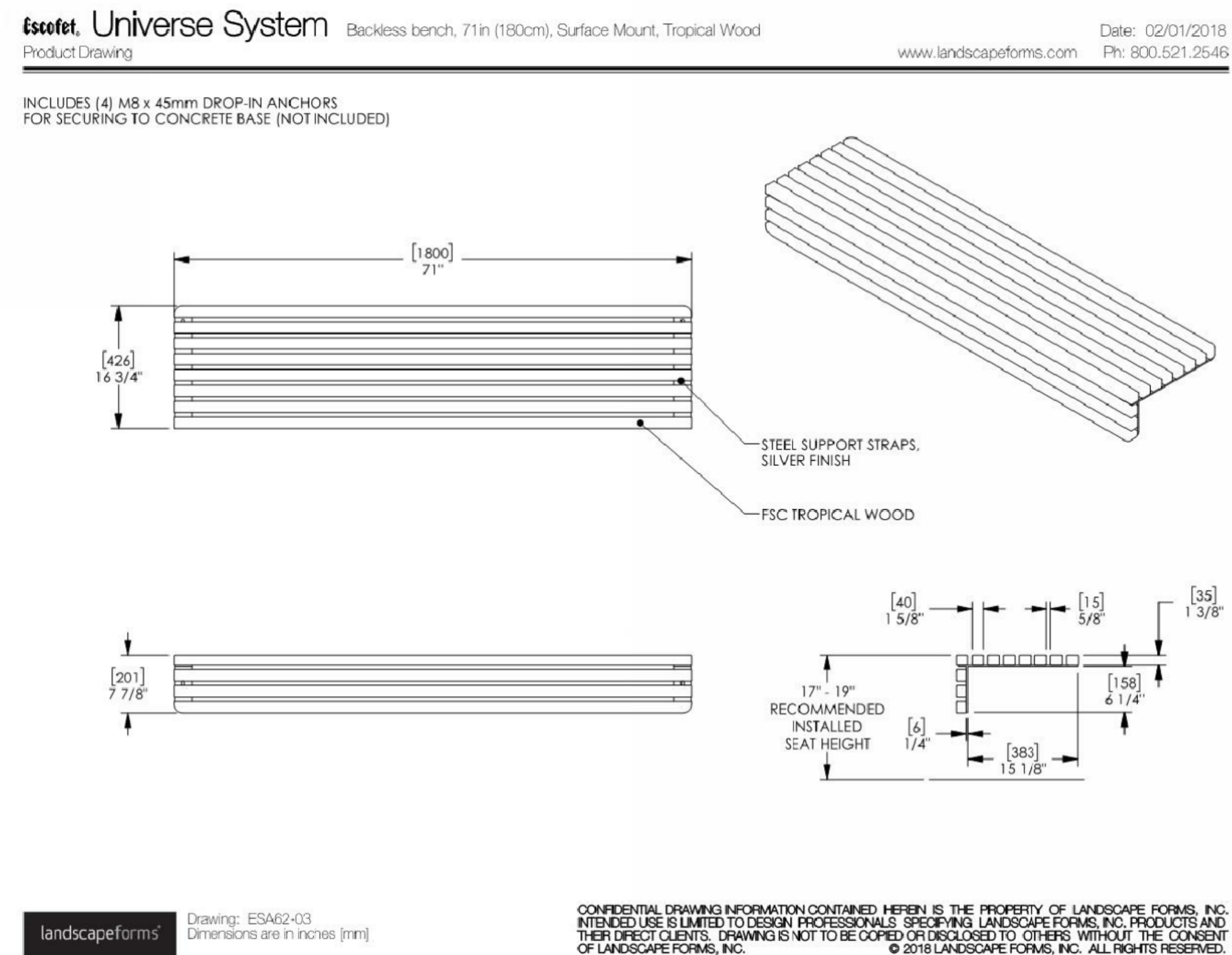

- NOTES:
 1. CONTRACTOR TO INSTALL PER MANUFACTURERS SPECIFICATIONS.
 2. BENCH TO BE LANDSCAPE FORMS ESCOFET UNIVERSE SYSTEM OR APPROVED EQUAL.

3 RECYCLING & TRASH RECEPTACLES
 SCALE: NTS

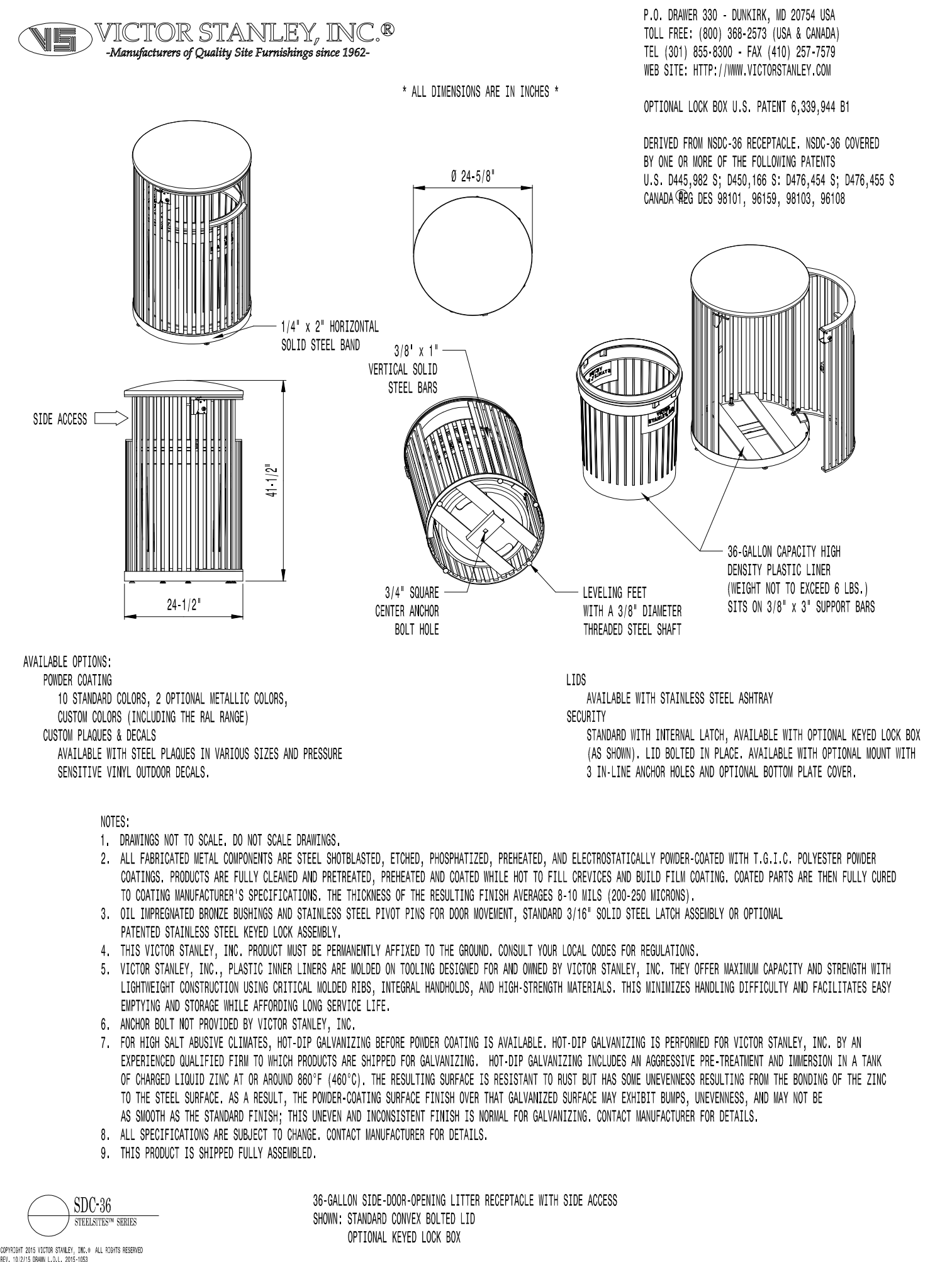

- NOTES:
 1. CONTRACTOR TO INSTALL PER MANUFACTURERS SPECIFICATIONS.
 2. RECYCLING & TRASH RECEPTACLES TO BE VICTOR STANLEY SDC-36 STEEL SITES COLLECTION OR APPROVED EQUAL.

4 SHRUB PLANTING
 SCALE: 1/2"=1'-0"

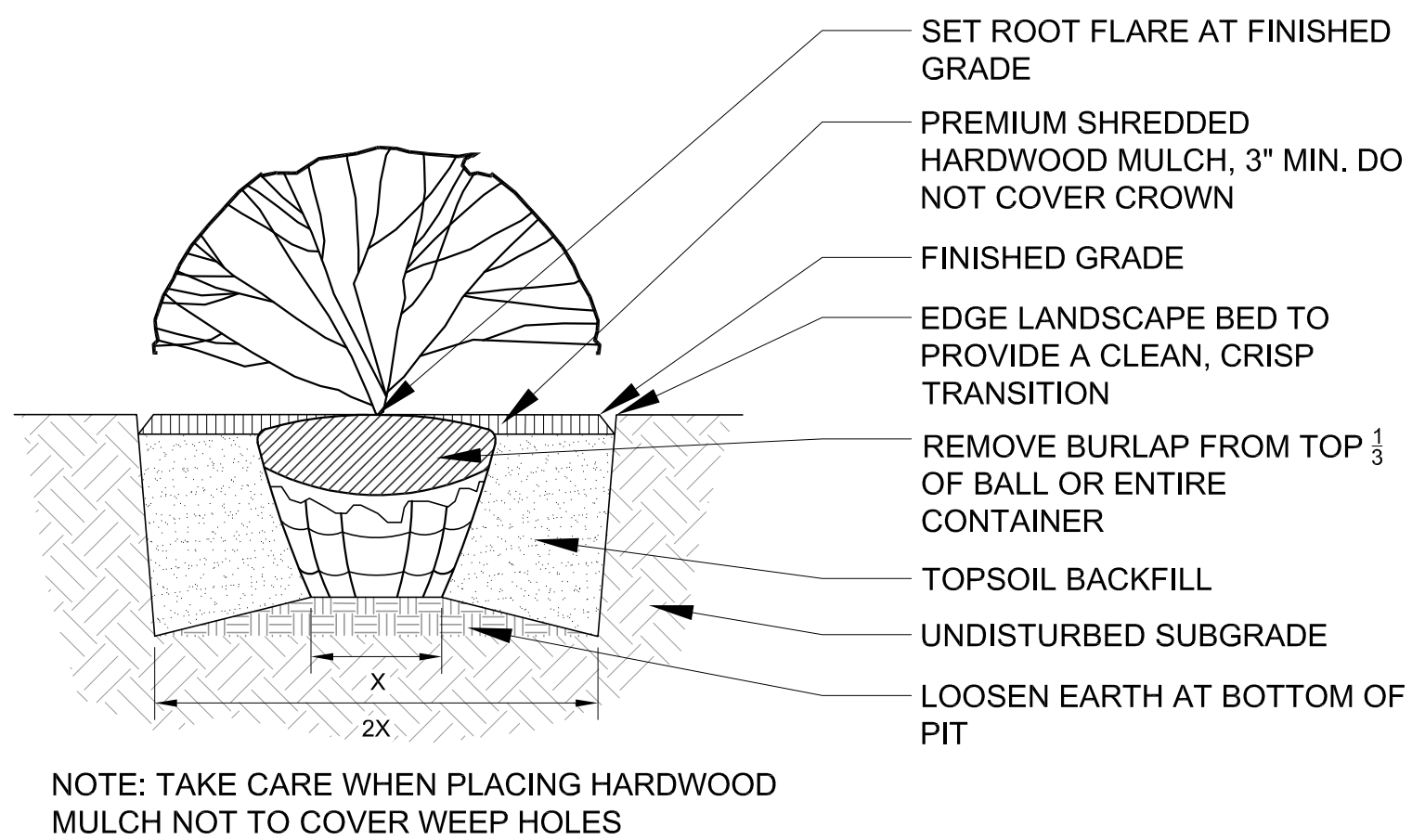

5 BACKLESS BENCH, SURFACE MOUNT 25"
 SCALE: NTS

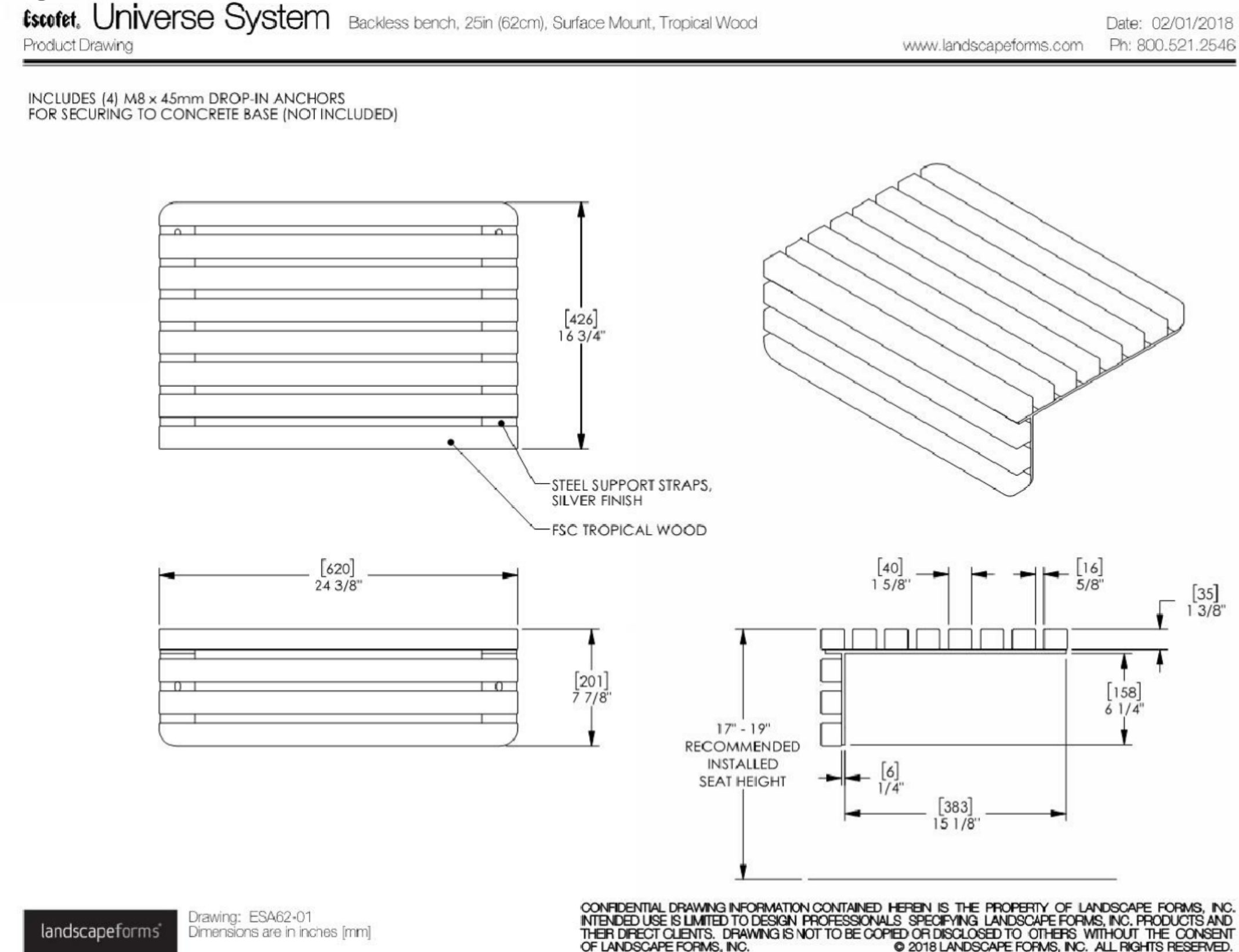

- NOTES:
 1. CONTRACTOR TO INSTALL PER MANUFACTURERS SPECIFICATIONS.
 2. BENCH TO BE LANDSCAPE FORMS ESCOFET UNIVERSE SYSTEM OR APPROVED EQUAL.

6 PERENNIAL PLANTING
 SCALE: 1/2"=1'-0"

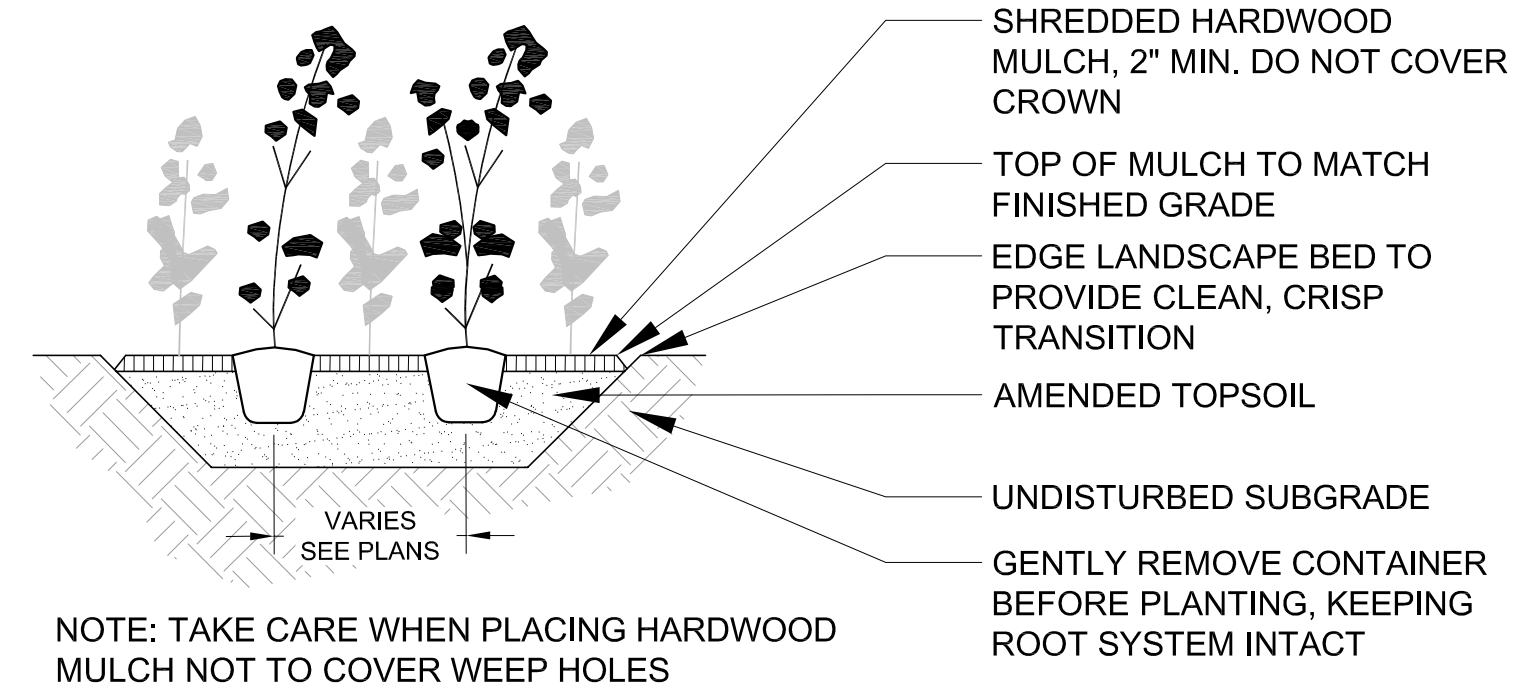

Wight & Company
 wightco.com
 2500 North Frontage Road
 Darien, IL 60561
 P 630.969.7000
 F 630.969.7979

REV	DESCRIPTION	DATE
	ISSUED FOR CONSTRUCTION-PHASE B	07.29.2019
19	ISSUED FOR DOC MOD 008	06.14.2019
	ISSUED FOR BID GROUP 7 - PHASE B	06.07.2019
14	ISSUED FOR ADDENDUM 2 - B66	06.05.2019
15	ISSUED FOR DOC MOD 005	06.03.2019
13	ISSUED FOR DOC MOD 004	05.16.2019
	FINAL PERMIT SUBMITTAL	05.13.2019
	ISSUED FOR BID - BID GROUP 6	05.10.2019
	ISSUED FOR BID - BID GROUP 5	05.10.2019
	ISSUED FOR CONSTRUCTION-PHASE A	05.08.2019

COMMUNITY SCHOOL DISTRICT 99 - MFP IMPLEMENTATION SOUTH HIGH SCHOOL
 1436 NORFOLK STREET
 DOWNERS GROVE, IL 60516

LANDSCAPE DETAILS SOUTH

Project Number:
 5274-02
 Drawn By:
 LR
 Sheet:

L2.00

SECTION 329200 – LAWNS AND GRASSES

PART 1 - GENERAL

1.1 DESCRIPTION

- A. The work includes furnishing and placing black earth (topsoil), fertilizer, seed and/or sod as stated in the project specifications, and performing all operations in connection with seeding and sodding, all complete and subject to the terms and conditions of the contract.

1.2 RELATED SECTIONS

- A. Drawings and general provisions of Contract, including General and Supplementary Conditions and other Division 1 Specification Sections, apply to this Section.
 - 1. Section 311000 – Site Clearing
 - 2. Section 312000 – Earth Moving
 - 3. Section 329100 – Soil and Landscape Bed Preparation, Landscape Excavation and Backfill
 - 4. Section 329300 – Woody and Herbaceous Plant Installation

1.3 DESCRIPTION

- A. Work includes furnishing all labor, materials and equipment required to complete the work described herein in strict accordance with the drawings and terms of the Contract.
- B. The landscape contractor shall be familiar with the project premises and how the existing conditions will affect the work.
- C. All previous grading to conform with the Drawings and Specifications

1.4 INSPECTION

- A. Become familiar with project requirements, site and existing conditions impact on scope of work
- B. Inspect existing conditions prior to commencing any work under this Section. Report any discrepancies to Landscape Architect.
- C. Failure to report discrepancies to Landscape Architect implies acceptance of existing conditions.

1.5 REFERENCES

- A. Illinois Department of Transportation “Standard Specifications for Road and Bridge Construction” (Standard Specifications) most recent edition

- B. ASTM International: ASTM C602 - Standard Specification for Agricultural Liming Materials.

1.6 DEFINITIONS

- A. Weeds: Vegetative species other than specified species to be established in given area.

1.7 SUBMITTALS

- A. Section 01 33 00 - Submittal Procedures: Requirements for submittals.
- B. Product Data: Submit data for seed mix, fertilizer, mulch, and other accessories.
- C. Manufacturer's Certificate: Certify Products meet or exceed specified requirements.
- D. Samples and Analysis:
 - 1. Submit, for review, samples and certified analysis by approved laboratory for seed,
 - 2. fertilizer, and lime prior to delivery to the site.
 - 3. Manufacturer's analysis for standard products will be acceptable.
- E. Acceptance of samples shall not be construed as final acceptance. The Landscape Architect reserves the right to have samples taken of the materials delivered to the site of the Work and analyzed for compliance with the Specifications.

1.8 CLOSEOUT SUBMITTALS

- A. Section 01 70 00 - Execution and Closeout Requirements: Requirements for submittals.
- B. Operation and Maintenance Data: Include maintenance instructions, cutting method and maximum grass height; types, application frequency, and recommended coverage of fertilizer.

1.9 QUALITY ASSURANCE

- A. Provide at least one person thoroughly trained and experienced in the skills required completely familiar with the design and application of the work described in this Section, and who shall be present at all times during progress of the work under this Section and shall direct all work required and performed under this Section.
- B. Provide seed mixture in containers showing percentage of seed mix, germination percentage, inert matter percentage, weed percentage, year of production, net weight, date of packaging, and location of packaging.
- C. Seed: Conform to current U.S. Department of Agriculture Rules and Regulations under the Federal Seed Act of August 9, 1939 and all subsequent revisions thereto, and the requirements of the state seed laws.

- D. Perform Work in accordance with Standard Specifications.

1.10 QUALIFICATIONS

- A. Seed Supplier: Company specializing in manufacturing Products specified in this section with minimum three years documented experience.
- B. Installer: Company specializing in performing work of this section with minimum five years documented experience.

1.11 WORKMANSHIP

- A. During seeding, keep all areas neat and clean and with precautions taken to avoid damage to existing plants, turf and structures.
- B. Remove all debris and waste material resulting from seeding operations from the project and the area cleaned up upon completion of seeding operation.
- C. Repair or restore to original condition any damaged areas caused by the landscape contractor.

1.12 PROTECTION AND REPAIR

- A. Use all means necessary to protect site seeding areas before, during, and after installation and to protect the installed work and materials of all other trades.
- B. In the event of damage to the site seeding areas including mulch or erosion control blanket, immediately make all repairs or replacements necessary to the approval of the Owner and at all no additional cost to the Owner.
- C. Install necessary barricades, temporary fences or signs to protect newly seeded or hydro-seeded/mulched areas until acceptance of the Work.

1.13 DELIVERY, STORAGE, AND HANDLING

- A. Section 01 60 00 - Product Requirements: Product storage and handling requirements.
- B. Deliver grass seed mixture in sealed containers. Seed in damaged packaging is not acceptable.
- C. Deliver fertilizer in waterproof bags showing weight, chemical analysis, and name of manufacturer.
- D. Protect seed, and other required materials against weather conditions and injuries during transit and job storage.
- E. Deliver all items to the site in their original containers with all labels intact and legible at time of Owners representative inspection.
- F. Use all means necessary to protect all items before, during and after installation and to protect the installed work and materials of all trades

G. Replacements:

1. Repair all damaged or rejected materials immediately
2. Make all repairs and replacements necessary to the approval of the Owners Representative at no additional cost to the owner.

1.14 GAURANTEE

- A. Guarantee this portion of the through the maintenance period and until final acceptance (See Paragraph 3.6 this section.)
- B. Within the guarantee period, replace all lawn areas which have failed to flourish and produce a stand of turf acceptable to the Owner due to defective materials or workmanship, or unfavorable weather conditions.
- C. The decision of the Owner for replacement Work shall be conclusive and binding upon the Contractor.
- D. The Contractor is responsible for all damage to persons or property caused by defective materials or workmanship or by the re-working of areas not acceptable.

PART 2 - PRODUCTS

2.1 MATERIALS

- A. Topsoil – See Section 329100 – Soil and Landscape Bed Preparation, Landscape Excavation and Backfill.
- B. Fertilizer
 1. Commercial Fertilizer shall be delivered to the site in unopened, original containers, each bearing name and address of the manufacturer, name brand or trademark and manufacturer's guaranteed analysis.
 2. Any fertilizer which becomes caked or otherwise damaged, making it unsuitable for use, will not be accepted.
 3. The fertilizer formula shall contain a minimum basis percentage by weight of the following:
Nitrogen, 33% insoluble in water 24%
Phosphoric Acid 4%
Potash 8%
 4. The balance of the fertilizer shall be made up of materials usually present in such a product, and shall contain IBDU (Isobutylidene Urea).
 5. Fertilizer shall be of the inorganic type in composition, dry and free flowing, equal to "PAREX" IBDU. Not more than 2% shall be retained on a 14-mesh sieve and not more than 25% shall pass thru a 65-mesh sieve. It shall be free from dust, sticks, sand, stone and other debris.

C. Kentucky Blue Grass Sod

1. General

a. Kentucky Blue Grass Sod

1. Kentucky Blue Grass Sod shall be nursery grown sod consisting of a blend of Kentucky Blue Grass species. with a minimum of two years growth. Sod shall show evidence of dense well-rooted growth and be practically free from weeds and non-specified species. Grass height of sod shall be approximately 2 inches. Sod shall be raked free of undesirable debris. Sod shall be as specified as follows or an approved equal:
2. It shall contain no bent grass, quack grass or other noxious weed growth and shall be free from fungus and other pests and/or diseases.
3. It shall be of firm, tough texture, having a compact growth of grass and good root development.
4. The sod root zone shall be of good, fertile, natural field soil and free from stones and debris and the sod shall contain sufficient moisture to maintain its vitality during transportation.

2. Harvesting of Sod

- a. Mowing: Before being cut and lifted, the sod shall have been mowed at least twice with a lawn mower, with the final mowing not more than seven days before the sod is cut.
- b. Cutting: The sod shall be carefully cut into uniform strips one inch thick, and 36-inches long. All strips shall be of the same width, which may be from 12-inches to 18-inches. Strips less than 12-inches or more than 18-inches in width will not be accepted. Each strip shall be rolled as compactly as is possible without breaking the turf.
- c. Sod cut for more than 24 hours shall not be used without the approval of the engineer.

3. Inspection of Sod

- a. All sod shall be fresh and green when placed. Any sod that is dried out, burned, inferior in quality, or in any way failing to meet the requirements of these specifications will be rejected and the Contractor shall immediately remove such rejected material from the premise and supply suitable material in its place.

PART 3 - EXECUTION

3.1 SITE PREPARATION

- A. Spreading and Rough Grading of topsoil as specified in Section 329100: Soil and Landscape Bed Preparation, Landscape Excavation, and Backfill. The Contractor shall spread and rough grade the areas to an elevation approximately 0.2 feet plus or minus below the finish grade as directed by the engineer. All equipment used for spreading and rough grading work shall be as approved by the engineer.

- B. Tilling: All areas to be seeded or sodded shall be thoroughly prepared to the required depth of approximately three inches, by disking, harrowing or by other approved means. Limited areas shown on the drawing, which are too small to make these operations practicable shall receive special scarification prior to final tilling. Tilling shall continue until the condition of the soil is acceptable to the engineer as suitable for the specified type of seeding or sodding. When conditions are such, by reason of drought, excess moisture, or other factors that satisfactory results are not likely to be obtained, the work will be stopped by the engineer and shall be resumed only when directed. Undulations or irregularities in the surface that would interfere with further Contractor's operations or maintenance shall be leveled before the next specified operation.
- C. Cleanup: After completion of tilling operations, the surface shall be cleared of all stones, stumps or other objects larger than 1-inch in thickness of diameter and of roots, brush, wire, grade stakes and other objects that may be a hindrance to maintenance operations. Adjacent paved areas shall be kept clean and soil or other dirt that may be brought upon the surface shall be removed promptly.
- D. Fine Grading: Final grades on the areas to be seeded or sodded are shown on the drawings by contour lines. The surfaces shall be left at the indicated grades in an even and properly compacted condition which insofar as practicable, will not provide dips and pockets where water may stand. Upon completion of tilling operations and immediately prior to sowing seed or placing sod, the area shall be finish graded as needed to correct surface irregularities produced by the preceding operations or by other cause and to restore design grades.

3.2 SPREADING FERTILIZER

- A. Fertilizer shall be distributed uniformly at a rate of 300 pounds per acres, over the areas indicated to be seeded or sodded, and shall be incorporated into the soil to a depth at least 2-inches by disking, harrowing or other acceptable methods. The incorporation of fertilizer may be a part of the tillage operation specified above.

3.4 SODDING

A. General

1. The surface on which sod is to be laid shall be firm and free from footprints or other depressions.
2. Sod shall be laid in such a manner that joints between courses do not coincide. Sod shall be tightly fitted and tamped lightly to ensure contact with the surface of the soil at all points.
3. All laid sod shall be protected from usage by workmen or equipment, so as not to disturb joints or cause depressions through footprints or vehicle ruts.
4. Any disturbed areas shall be redone to conform to grade.
5. On slopes steeper than 2:1 and elsewhere where so directed, the sod shall be fastened in place with suitable wooden pins or by other approved methods.

B. Watering

1. Sod shall be thoroughly watered immediately after installation.

2. The sod shall be watered as often as necessary to ensure sufficient water shall be applied to wet the sod bed at least 2-inches deep.
3. Watering shall be done in a manner that will avoid erosion due to application of excessive quantities, and the water equipment shall be of a type that will prevent damage to the finished surfaces.
4. If water is not available on site, the Contractor shall supply water from his own source. The Contractor shall furnish the hose and proper equipment for watering purposes.

C. Mowing

1. The Contractor shall be solely responsible for mowing during construction.

D. Sodded lawn areas to be acceptable shall be in a green and healthy condition, devoid of bare spots.

E. Protection

1. The Contractor is responsible for the proper care of the sodded areas during the period when the vegetation is being established.
2. Newly sodded areas shall be protected against traffic or other use, by enclosing the areas with snow fencing or other approved barrier.
3. "NEWLY SODDED" or other appropriate approved warning placards shall be posted until all work under the contract is completed and accepted.

F. Repair

1. If at any time before completion and acceptance of the entire work covered by this contract, any portion of the sodded surface becomes damaged, dies due to lack of water, becomes rutted due to improper protection, has been winter-killed or otherwise damaged or destroyed, the affected portion shall be repaired to re-establish the condition and grade of the soil prior to sodding and shall then be resodded as specified hereinbefore by the Contractor, at no additional cost to the Owner.

G. Maintenance during Sod Establishment: Maintenance including watering of grass shall continue until all sodding work under this contract has been completed and accepted by the Owner.

3.5 MAINTENANCE

A. Maintenance

1. The Contractor shall be responsible for maintenance until 30 days after the certificate of substantial completion. After the 30 day period from the date on the certificate of substantial completion, the Owner shall be responsible for all aspects of the maintenance.
2. Maintenance during this time period shall include all requirements aforementioned within this specification.
3. The contractor is responsible for the control of weeds during establishment and the maintenance period. Weeds shall be spot treated with a broad-leaved herbicide that is safe for grass or hand pulled. Do not broadcast herbicide applications. The contractor shall remedy all damage resulting from improper herbicide use.

3.6 ACCEPTANCE

A. Completion of the Work

1. Upon completion of work, the Contractor shall notify the Landscape Architect and the Owner at least ten (10) days prior to requested date of substantial completion of all or portions of the work. Landscape Architect will review all of the work and prepare a punch list of work not installed or not installed in conformance with the contract documents. All work in the punch list must be completed within five (5) working days from date of issue. Where work does not comply with requirements, replace rejected work and continue specified protection and maintenance until reviewed by Landscape Architect and found to be acceptable.

B. Certificate of Substantial Completion

1. Certificate of substantial completion will be issued for acceptable work at sole discretion of the Landscape Architect. If punch list items are issued with the certificate, they must be corrected within five (5) working days. If items are not corrected within five (5) working days than the certificate of substantial completion will be revoked and reissued when the punch list items are corrected.

C. Final Acceptance

1. After the 30 day maintenance period following the date of substantial completion the Landscape Architect and the Owner will review the work for final acceptance. Upon satisfactory completion of repairs and / or replacements the Landscape Architect will certify, in writing, final acceptance of the work, which will serve as evidence that Contractor's obligations have been met.

END OF SECTION 329200

SECTION 329300 – WOODY AND HERBACEOUS PLANT INSTALLATION

PART 1 - GENERAL

1.01 DESCRIPTION

- A. Provide, install, and maintain trees, shrubs, vines, and herbaceous materials as shown and specified in the contract plans. The work includes:
1. Woody plant material including trees, shrubs, and vines
 2. Herbaceous plant material including annuals, biennials, perennials, ornamental grasses, vines, bulbs, and plugs
 3. Mulch and Planting Accessories
 4. Existing Tree Care
 5. Maintenance and Warranty Period

1.02 RELATED SECTIONS

- A. Section 329100 – Soil and Landscape Bed Preparation, Landscape Excavation and Backfill
- B. Section 329200 – Lawns and Grasses

1.03 QUALITY ASSURANCE

A. Qualifications

1. The Contractor shall be a company specializing in landscape installation with a minimum of five (5) years of experience on comparable projects.

B. Code and Standards Compliance

All materials and work shall comply with applicable sections of the following references:

1. American Association of Nurserymen, Inc. (MN) Standard: American Standard for Nursery Stock (ANSI Z60.1 -1990)
2. Hortus Third, Cornell University, 1976

C. Source Quality Control

1. All landscape materials shall be from stock inspected and certified by authorized governmental agencies. The stock shall comply with governmental regulations prevailing at the supply source and the job site. The Architect reserves the right to ask for certification by authorized governmental agencies.
2. All landscape materials that have been treated with herbicides, pesticides, insecticides, fungicides, etc. should have been applied by a licensed applicator and been treated with products that comply with governmental regulations. The Architect reserves the right to ask for certification.

3. Products packaged in sealed containers shall be labeled with manufacturer's certified analysis. The composition of bulk materials shall be tested by an approved laboratory in accordance with procedures established by the Association of Official Agricultural Chemists, wherever applicable, or as specified by product specifications referenced herein.
4. Plant Material Selected by Contractor
 - a. Contractor shall locate all plant material to be supplied for the project and inform the Landscape Architect and Owner in writing of plant location(s) at least thirty (30) days prior to scheduled installation date.
 - b. In the event plant material is found to be unacceptable after review by the Landscape Architect, the Contractor shall pursue other sources until acceptable plant material is found, at no additional cost to the Owner and Landscape Architect.
 - c. Selection or lack of selection at the plant source does not impair the right of the Landscape Architect to review and reject material at the time of shipping, during installation of the work, or after the installation of the work.

D. Substitutions

1. If specified landscape material is not obtainable, notify the Landscape Architect, who will identify alternate sources or substitutes. If substitutions are smaller in size than the specified material, credits to the base bid contract will be made based on comparable cost differentials customary for materials and sizes involved.

1.04 SUBMITTALS

A. Qualifications

1. The Contractor shall submit qualifications.

B. Nursery List

1. Submit nursery list that complies with the above items under Section 1.03, Quality Assurance.

C. Samples and Product Data

1. Submit samples and/or product data for all items listed below in Section 2.01, Materials.

D. Schedule

1. Upon authorization to proceed with the work, a schedule indicating the dates of each of the following items will be prepared by the Contractor and submitted to the Landscape Architect:
 - a. Tagging of plant material in nurseries.
 - b. Staking of plant locations on the site.
 - c. Digging and preparation of plant pits and beds.
 - d. Delivery of plant material to the site.

- e. Planting schedule.
- f. Substantial completion of the work.

1.05 PRODUCT DELIVERY, STORAGE, AND HANDLING

A. General

- 1. Notify the Landscape Architect and the Owner forty-eight hours in advance of all delivery times for plant material.
- 2. Store materials only in locations approved by the Landscape Architect and the Owner.

B. Packaged Materials

- 1. Deliver packaged materials in unopened containers showing weight, analysis, and name of manufacturer. During shipment and storage on site, protect materials from breakage, moisture, heat, or other damage and according to manufacturer's recommendations.

C. Woody and Herbaceous Plant Materials

- 1. Schedule shipping to minimize on site storage of plants. Stock shall not be shipped until the planting preparations have been completed.
- 2. Label the size and variety of plant and securely attach to individual plants or to bundles of like variety and size.
- 3. During shipment, plants shall not be bent, stacked, or bound in a manner that damages bark, breaks branches, deforms root balls, or destroys natural shape.
- 4. Plant material shall be transported within enclosed trailers or covered by tarpaulin to protect the material from damage caused by drying winds, heat, freezing, or other exposure that may be harmful to the plants. Plant material arriving at the site in a damaged condition shall be rejected and removed from the site.
- 5. If delays beyond the Contractor's control occur after delivery, plants shall be kept watered and protected from sun, wind, and mechanical damage; root balls shall be covered with topsoil or mulch. Container-grown stock shall not be removed from containers until planting time. Keep the roots constantly moist until planted.
- 6. Handle plants at all times in accordance with the best horticultural practices. Lift balled and burlapped materials from the bottom of the ball only. Balled and burlapped plants which have cracked or broken balls shall be rejected and removed from the site.

PART 2 - PRODUCTS

2.01 MATERIALS

A. Woody and Herbaceous Plant Material

- 1. Provide plant materials true to name and variety established by the American Joint Committee on Horticultural Nomenclature Standardized Plant Names, Second Edition, 1942, as indicated on the Drawings.
- 2. All planting stock shall be nursery-grown in accordance with good horticultural practice. Plants shall be free of disease, insects, eggs, larvae, and defects such as knots, sunscald, injuries, abrasions, or disfigurement. They shall be sound, healthy and

vigorous, of uniform growth, typical of the species and variety, well formed, free from irregularities, with the minimum quality conforming to American Standard for Nursery Stock.

3. Plants indicated, as "specimen plants" shall be exceptionally heavy, symmetrical, and tightly knit, cultured, to be unquestionably superior in form, branching, compactness, and symmetry.
4. Plants indicated as plugs shall be, at a minimum, grown in 2 ½ inch diameter containers with sidewall grooves, ribs, or slits.
5. The minimum acceptable sizes of all plants shall be measured before pruning and with branches in normal position. Unless otherwise designated on the drawings, all plant dimensions shall conform to those listed in ANSI Z60.1, American Standard for Nursery Stock.
 - a. Where height is indicated within a range, the smaller dimension is the minimum acceptable; the larger dimension represents the maximum permissible except with approval of the Landscape Architect. The average dimension of all plants must at least equal the average of the height range specified.
 - b. Spread shall meet the minimum dimension specified in all directions and must be considered as pivoting on the center of the plant. Where range is shown between two spread dimensions, the smaller dimension is the minimum acceptable. Spreads shall at least average on the average of the range indicated.
 - c. Caliper is the trunk diameter taken at a specified distance above root collar as described in ANSI Z60.1.
 - d. Branching point is the distance above ground where balanced branching occurs or where a dimension on trunk appears to form the head of the tree.
 - e. Provide plant material of sizes shown or specified. Plant material of a larger size may be used, if acceptable to the Landscape Architect, and if sizes of roots or root-balls are increased proportionately in accordance with ANSI Z60 standards or greater. Increased size shall result in no additional cost to the Owner.
6. Root Treatment
 - a. Root treatments on all plants shall conform to the requirements of ANSI Z60.1. Plants shall be dug and prepared for shipment in a manner that will not cause damage to branches, shape, and future development after planting.
 - b. Balled and burlapped (B & B) plants shall have a firm, natural ball of earth of sufficient diameter and depth to encompass the fibrous and feed root systems necessary for full recovery of the plant. Ball shall be securely wrapped with burlap and bound with cord. Ball sizes shall meet the requirements of the ANSI Z60.1.
 - c. Plants furnished in containers shall have the roots well established in the soil mass and shall have grown in the container for at least one growing season. Containers shall be large enough to provide earth-root mass of adequate size to support the plant tops being grown. Plants, other than ground covers, over-established in the container, as evidenced by pot-bound root ends, will not be accepted.
7. Plant materials shall be subject to final approval by the Landscape Architect at the site. The Landscape Architect reserves the right to reject any plant material that does not meet project specifications at the time of planting.

B. Topsoil

1. Topsoil for landscape work shall be amended as specified in specification section 329100, Soil and Landscape Bed Preparation, Landscape Excavation and Backfill.

C. Backfill

1. Backfill for landscape work shall be amended as specified in specification section 329100, Soil and Landscape Bed Preparation, Landscape Excavation and Backfill.

D. Shredded Hardwood Bark Mulch

1. Hardwood bark mulch shall be shredded or double-ground, composted hardwood, not to exceed two (2) inches in its largest dimension, free of foreign matter, sticks, stones, roots, soil and/or other unacceptable material.
2. Proportion of fines (material passing sieve size #60) shall not exceed 10% as determined by weight.
3. Contractor shall provide a 1 quart (minimum) sample of mulch to the Landscape Architect project manager for review and approval, before starting work.

E. Anti - Transpirant

1. Anti - transpirant shall be a protective film emulsion providing protective film over evergreen plant surfaces only, permeable to permit transpiration, as manufactured by Wilt Pruf Products, Inc. or approved equal. Mix and apply in accordance with manufacturer's instructions.

F. Herbicide

1. Herbicides shall be products with rates of application that conforms to registered uses and is applied by a licensed professional applicator.
 - a. For woody materials ten (10') feet or further from a water body: Garlon 4 herbicide as manufactured by DowElanco or approved equal.
 - b. For woody and/or herbaceous material ten (10') feet or further from a water body: Roundup Pro herbicide as manufactured by DowElanco or approved equal.
 - c. For woody and herbaceous materials within ten (10') feet of a water body: Rodeo herbicide as supplied by DowElanco or approved equal.

G. Pesticides, Insecticides, Fungicides, etc.

1. If plant material becomes infected with any pests or insects, the most practical and environmentally benign methods should be utilized to control the problem. All products should comply with government regulations and be applied by a licensed applicator. The Landscape Architect reserves the right to ask for certification.

H. Water

1. If water is not available on site, the Contractor shall supply water from his own source. The Contractor shall furnish the hose and proper equipment for watering purposes.

I. Tree Watering Bags

1. Tree watering bags shall be by Treegator or approved equal. Bags shall be installed for all trees installed from June 1 through September 15.

J. Guying and Staking Materials

1. Guying and staking shall only be performed as noted on the plans or as directed by the Landscape Architect.
2. Stakes for tree support shall be hardwood free from knot, rot, cross grain or other defects that would impair strength. Stakes shall be a minimum of 2" by 2" in diameter by 8'-0" long and pointed on one end.
3. Ground anchors for guying shall be 2" x 2" x 3'-0" long wood stake, pointed on one end.
4. Guying wire shall be 12 gauge annealed galvanized steel.
5. Guying cable shall be a minimum of five strands, making a 3/16" diameter steel cable.
6. Hose chafing guards shall be new or used 2-ply, one half inch reinforced rubber or plastic hose and shall be the same color on the project. Length shall be one and one-half times the circumference of the plant at its base.
7. Survey flags to be fastened to guys shall be white plastic surveyor's tape, 6" in length.
8. Turnbuckles shall be galvanized or cadmium-plated steel and have a 3" minimum lengthwise opening fitted with screw eyes.

PART 3 - EXECUTION

3.01 PROJECT CONDITIONS

A. General

1. Prior to beginning work, the Contractor shall examine and verify the acceptability of the job site and notify the Owner of unsatisfactory conditions. Do not proceed with the work until unsatisfactory conditions have been corrected or resolved.
2. Where planting occurs in close proximity to other site improvements, provide adequate protection for all site areas prior to commencing work. Any items damaged during planting operations shall be promptly replaced or repaired to their original condition at the Contractor's expense and no additional cost to the Owner.
3. A list of plants, including a schedule of sizes, quantities, and other requirements is shown on the drawings for convenience of the Owner. Verify and supply the quantities required to complete the work as drawn.

B. Utilities

1. Contractor shall be solely responsible for determining location of all utilities. Contractor shall be responsible for obtaining site utility plans and contacting local utility locator service, and shall perform no work on site until utility locator service has marked site utilities. Perform work in a manner that will avoid possible damage. Excavate to avoid underground utilities including hand digging as required. All damage to utilities resulting from work covered in these contract documents will be repaired at the Contractor's expense and no additional cost to the Owner. No time extension will be allowed due to delay in utility location.

C. Planting Season

1. Plant material shall be dug and planted only during the planting season appropriate for each individual plant species. Pre-digging of plants with proper storage may extend the planting season. However, the installation of plant material outside the normal planting season shall be done only with the approval of the Landscape Architect.
2. Evergreen Material: Plant evergreen materials between September 2 and November 1 or in spring before new growth begin. If project timeline requires planting at other times, spray plants with anti-transpirant prior to planting operations.
3. Deciduous Trees: Plant deciduous trees in a dormant condition. If deciduous trees are planted in-leaf, spray with an anti-transpirant prior to planting operations.
4. Woody Material: Plant woody plant materials in Spring between April 1 to June 30 or in Fall between September 1 to November 30.
5. Herbaceous Material: Plant herbaceous materials (including plugs) in Spring between April 15 (with no threat of frost) and June 30 or in Fall between September 1 to October 15.
6. Bulbs: Plant bulbs in a dormant condition between November 1 and 30.
7. When the ground is frozen, no planting activities shall occur.

D. Coordination with Other Work

1. Proceed with complete landscape work as rapidly as portions of the site become available, working within the season limitations for each kind of landscape work is required.

3.02 PREPARATION

A. Layout

1. Layout and plant installation cannot begin until all landscape bed preparation, as detailed within Section 329100, and final grading has been achieved. Once complete, the Contractor must layout all planting areas as shown on the contract drawings/plan. The layout must be performed by qualified personnel. The tree and shrub locations must be marked by staking and all bed limits must be painted. The Landscape Architect must approve the layout prior to installation.
2. Individual plant locations for trees and shrubs as noted on the plan shall be staked on the project site by the Contractor and approved by the Landscape Architect before any planting operations commence. The Landscape Architect reserves the right to adjust plant material locations to meet field conditions, without additions to the base contract price.
3. Accurately stake plant material according to the drawings. Where location or spacing dimensions are not clearly shown, request clarification from the Landscape Architect.
4. If obstructions are encountered that are not indicated, do not proceed with planting operations until alternate plant locations have been selected and approved in writing by the Landscape Architect.
5. If alternate locations are not possible, notify the Landscape Architect of the adverse conditions so the Landscape Architect can request a proposal from the Contractor for method of correction. The Contractor shall obtain approval from the Owner for the additional work prior to continuing work in the affected area.

3.03 PERFORMANCE

A. General

1. Rocks/underground obstructions shall be removed and proper planting depths shall be established to conform to Section 329100 – Soil and Landscape Bed Preparation, Landscape Excavation and Backfill.
2. Plant Pit Excavation
 - a. Planting pits shall be round, with vertical sides and flat bottoms, and sized in accordance with the specification and dimensions shown on the drawings.
 - b. If rotating augers or other mechanical diggers are used to excavate holes, the vertical sides of the pits shall be scarified, fractured, or otherwise broken down to eliminate impervious surfaces.
 - c. Loosen or scarify soil in the bottom of all plant pits to a depth of four (4") inches.
3. Existing native topsoil are to be used as backfill during installation. The existing native topsoil used for herbaceous or shrub backfill shall meet the requirements as specified within Section 329100 – Soil and Landscape Bed Preparation, Landscape Excavation and Backfill. Landscape beds shall be excavated to proper depths and amended as specified. Landscape beds shall be brought to a smooth and even surface conforming to established grades.

B. Planting Operations

1. When the ground is frozen, no planting activities shall occur.
2. Balled and burlapped (B & B) trees and large shrubs:
 - a. Set the plant in the pit to the same relationship to the grade as in the original container or at the top of the burlap ball, faced to give the best appearance or relationship to one another and adjacent structures. Cut away burlap, rope, wire, or other wrapping materials one-third (1/3) of the way from the top of the ball and remove from pit. Do not remove burlap or ties from sides or bottom of ball. If plastic wrap or other non-biodegradable materials are used in lieu of burlap, completely remove them before placing of backfill. Cleanly cut off broken or frayed roots. Place approved topsoil and fertilizer around the ball and carefully compact to avoid injury to the roots and to fill the voids. Apply fertilizer at a rate recommended by the manufacturer. After backfilling planting pit, approximately two-thirds full, add water and allow planting mixture to settle. After the water has been absorbed, fill the planting pit with topsoil tamp light to grade and form a watering basin of the size indicated. In tree grates, set top of root ball to allow a two-inch air space between the mulch layer and the bottom of the grate.
 - b. Plant container-grown shrubs as specified above for balled and burlapped plants and as modified herein. Remove containers before planting and loosen the sides of root ball in several places, freeing the roots on the outside of the ball sufficiently to encourage rapid root extension into the surrounding soil and to prevent girdling of root mass.

3. Plant groundcover, perennials, plugs and annuals so that the top of the root mass is even with the surrounding grade. Adjust spacing as necessary to evenly fill planting bed with indicated quantity of plants. Backfill planting with specified planting mixture and fertilizer at a rate recommended by manufacturer.
4. Where erosion control blanket is specified on the plan documents, plant herbaceous plugs after placement of erosion control blanket. Contractor will be required to carefully slit installed erosion control blanket for plug installation. Contractor shall ensure minimal disturbance to the erosion control blanket during installation.
5. Plant bulbs to the depths and spacing as indicated on the plans and details.
6. Planting of shrubs, groundcovers, bulbs and annuals around tree root balls shall occur beyond the perimeter of the root ball. Do not plant directly over any root balls.

C. Mulching

1. General

- a. Mulch shall be applied by hand, with appropriate tools and equipment, in such a way as to prevent and preclude damage to the plant material being mulched. Plant material damaged or destroyed due to improper mulching operations will be replaced by the contractor, at his expense.
- b. Plant material shall be mulched with approved mulch to the following depths:
- c. Shredded Hardwood Bark Mulch
 1. Woody plant material to receive a maximum depth 4"; minimum 3" of shredded hardwood bark mulch
- d. Mulch shall be applied evenly over the entire area to be mulched with the following exceptions:
 1. Mulch shall be held back a minimum of 1" from the base of tree trunks, and tapered up to the adjacent depth.
 2. Mulch shall not be placed against, among or between the trunks or stems of multi-stemmed trees, shrubs, perennials, or any other plant material.
 3. Leafy stems of groundcover or vines shall not be buried under mulch material.
 4. Plant material requiring differing depths of mulch which are present in one planting bed shall be mulched to each plant type's required depth; transitions between areas of differing depths of mulch shall be accomplished as to minimize uneven surfaces.
- e. Prior to installation of new mulch, old decomposed mulch is to be removed as necessary to proper depth of new mulch.
- f. "Volcano" mulching, the practice of heaping mulch against the stems or trunks of plant material is strictly forbidden. Plant material with bark or trunk damage due to this practice will be replaced by the Contractor, at his expense.

2. Mulch tree rings

- a. Maintain and/or re-establish existing mulched tree rings

1. Remove excess or decomposed mulch to prevent build up over tree roots and/or against the trunk
 2. Mulched tree rings shall be a minimum of 6 ft diameter on trees of 8" caliper or less; larger trees shall have mulch rings a minimum of 3 ft radius, measured from the outside of the base of the tree (for a tree 24" in caliper, the mulch ring will be 8 ft in diameter: $3\text{ ft} + 24" + 3\text{ ft} = 8\text{ ft}$).
 3. Supply and install approved shredded hardwood mulch to trees rings as needed to bring mulch depth to that specified.
 4. Edge mulch rings as necessary to maintain a clean, crisp edge.
- b. Establish new mulched tree rings
1. Remove grass, weeds and all other existing cover, including surface roots, from areas to be developed as mulch rings.
 2. Mulched tree rings shall be a minimum of 6 ft diameter on trees of 8" caliper or less; larger trees shall have mulch rings a minimum of 3 ft radius, measured from the outside of the base of the tree (for a tree 24" in caliper, the mulch ring will be 8 ft in diameter: $3\text{ ft} + 24" + 3\text{ ft} = 8\text{ ft}$).
 3. Edge mulch rings as specified on drawings.
 4. Supply and install approved shredded hardwood mulch to depth as specified.
- c. Edging of tree rings
1. All tree rings within lawn or turf areas are to be edged as necessary to maintain a clean, crisp appearance.
 2. Edging is to be accomplished by hand with an edging tool, or by using a rotating or vibrating blade power driven machine which produces a maximum 2" deep x 2" wide trench at the transition edge. Edging machines which produce a cut deeper than 2" are not acceptable.
 3. All edging work is to be performed and accomplished in such a way as to prevent and preclude damage or injury to surface roots.
 4. All debris generated by edging activities is to be removed from adjacent surfaces.
3. Mulch Perennial and Shrub Landscape Beds
- a. Maintain and/or re-establish existing mulched landscape beds
1. Remove excess or decomposed mulch to prevent build up over crown of plant
 2. Supply and install approved shredded hardwood to landscape beds as needed to bring mulch depth to that specified.
 3. Edge existing landscape beds as necessary to maintain a clean, crisp edge.
- b. Establish new landscape beds
1. Remove grass, weeds and all other existing cover in areas shown in plans, including surface roots as directed by landscape architect, from areas to be developed as planting beds.
 2. Mulched landscape beds shall have a clearance buffer of (6) six inches between the first row of planting and landscape bed edge.
 3. Supply and install approved organic shredded leaf mulch to depth as specified.

c. Edging of landscape beds

1. All landscape beds within lawn or turf areas are to be edged to maintain a clean, crisp appearance.
2. Edging is to be accomplished by hand with an edging tool, or by using a rotating or vibrating blade power driven machine which produces a maximum 2" deep x 2" wide trench at the transition edge. Edging machines which produce a cut deeper than 2" are not acceptable.
3. All edging work is to be performed and accomplished in such a way as to prevent and preclude damage to existing and installed plant material.
4. All debris generated by edging activities is to be removed from adjacent surfaces.

D. Pruning

1. General

- a. Pruning is to be performed by Certified Arborists only. Plant material is to be pruned only to remove damaged or broken material. The Architect shall approve pruning techniques and appearance before proceeding with all pruning.
- b. Trimmings shall be removed from the site and legally disposed.

2. Trees

- a. Prune trees by removing all dead wood, badly formed, interfering limbs, and sufficient other growth to ensure healthy and symmetrical growth of new wood. The proportion is, in all cases, subject to the approval of the Architect. The central leader shall not be removed.
- b. In the case of multiple leaders, preserve the one which will best promote the symmetry of the tree, and remove or cut back the remainder so that they will not compete with the selected leader. Cut back surrounding top branches to conform to the leader.
- c. Specified multi-Stem trees are to be pruned per the direction of the landscape architect to help maintain canopy clearance for accessibility and room for lower landscape plantings.
- d. Contractor to contact landscape architect at least 24 hours before installation and before commencement of pruning activities.

3. Shrubs

- a. Prune shrubs by removing all dead wood and broken branches, thinning out canes and cutting back or removing asymmetrical branches. Pruning shall result in a loose outline conforming to the natural shape of the shrub type. Shearing to unnatural shapes will not be accepted.

3.04 CLEAN UP AND PROTECTION

A. Clean Up

1. Excess and waste material shall be removed daily. Keep pavement clean and work area in an orderly condition.
2. When planting in an area has been completed, the area shall be cleared of all debris, soil piles, containers and all paved areas swept.
3. At least one paved pedestrian access route and one paved vehicular access route to each building shall be kept clean at all times. Other paving shall be cleaned when work in adjacent areas is completed.

B. Repairs

1. Any damage to existing landscape, paving, or other such features as a result of work related to this contract shall be repaired by the responsible Contractor to its original condition. Treat, repair, or replace damaged work at the Contractor's expense and at no additional cost to the Owner.

C. Protection

1. Protect landscape work and materials from damage due to landscape operations, operations by other contractors and trades, and trespassers. Maintain protection during installation and maintenance periods.

D. Insurance

1. Insurance on plant material and other materials stored or installed is the responsibility of the Contractor. Such insurance shall cover fire, theft, vandalism, and any other damage that may occur to the plant material. Should the Contractor elect not to provide such insurance, the Contractor will in no way hold the Owner responsible for any losses incurred during the project. The Contractor is responsible for all costs incurred in replacing materials prior to date of substantial completion.

3.05 MAINTENANCE

A. Maintenance

1. The Contractor shall be responsible for maintenance until 1 year after the certificate of substantial completion. After the 1 year period from the date on the certificate of substantial completion, the Owner shall be responsible for all aspects of the maintenance. The Contractor should review the site periodically during the warranty period to determine what changes, if any, should be made in the maintenance program.
2. Maintenance during this time period shall include pruning, cultivating, weeding, watering, and application of appropriate insecticides and fungicides necessary to maintain plants free of insects and disease.
 - a. Re-set settled plants to proper grade and position. Restore and replenish mulch beds per specifications.
 - b. Water-in woody and herbaceous plant material at the time of initial planting. Water should be enough to saturate the soil and provide adequate coverage to settle the soil and remove any air pockets or voids within the planting bed. If settling occurs add additional topsoil and mulch as necessary to restore the final grade as shown on

- plans taking care to not cover crowns. Additional material needed to perform this work shall come at no additional cost to the Owner.
- c. After initial water-in, the Contractor is responsible to water the plant material at a minimum of twice per week until 1 year after substantial completion during the first growing season.
3. Maintenance review should occur at a minimum of 1 time per month during the warranty period to confirm the condition of plant material.

3.06 ACCEPTANCE

A. Completion of the Work

1. Upon completion of work, the Contractor shall notify the Landscape Architect and the Owner at least ten (10) days prior to requested date of substantial completion of all or portions of the work. Landscape Architect will review all of the work and prepare a punch list of work not installed or not installed in conformance with the contract documents. All work in the punch list must be completed within five (5) working days from date of issue. Where work does not comply with requirements, replace rejected work and continue specified protection and maintenance until reviewed by Landscape Architect and found to be acceptable.

B. Certificate of Substantial Completion

1. Certificate of substantial completion will be issued for acceptable work at sole discretion of the Landscape Architect. If punch list items are issued with the certificate, they must be corrected within five (5) working days. If items are not corrected within five (5) working days than the certificate of substantial completion will be revoked and reissued when the punch list items are corrected.

C. Warranty

1. Maintain and warrant for a period of one (1) year, following the certificate of substantial completion, all work, against any defects (including death and unsatisfactory growth) as determined by the Landscape Architect. Defects resulting from neglect by the Owner, abuse or damage by others, or unusual phenomena or incidents beyond the Contractor's control are exceptions. Should questions arise concerning the responsibility of replacement, the Landscape Architect shall be the sole judge of the need for replacement.
2. Remove and replace all work found to be dead or in unhealthy condition during warranty period as determined by Landscape Architect.
3. Replacements shall match adjacent specimens of same species. Replacements are subject to all requirements stated in the contract documents and are subject to review by the Landscape Architect at the project site and should be installed during appropriate planting seasons.
4. Repair grades, paving and any other damage resulting from replacement planting operations, at no additional cost to the Owner.
5. Replacements made during the warranty period or following review for final acceptance will carry an additional one (1) year warranty beginning at the time of replacement.

D. Final Acceptance

1. One (1) years after date of substantial completion the Landscape Architect and the Owner will review the work for final acceptance. Upon satisfactory completion of repairs and / or replacements the Landscape Architect will certify, in writing, final acceptance of the work, which will serve as evidence that Contractor's one (1) year warranty obligations have been met.

END OF SECTION 329300

SECTION 329100 – SOIL AND LANDSCAPE BED PREPARATION,
LANDSCAPE EXCAVATION AND BACKFILL

PART 1 - GENERAL

1.01 DESCRIPTION

A. Section Includes

1. Stockpile excavated topsoil and relocate on site to meet finished grade elevations.
2. Furnish and place of subsoil, topsoil, and organic compost to meet finished grade elevations.
3. Soil testing of supplemental topsoil.
4. Preparation and placement of topsoil in landscape planting beds and turf areas to required finished grades including all soil amendments.
5. Finished grading of all landscape beds and turf areas.

1.02 RELATED SECTIONS

A. Section 312100 – Rough Grading

B. Section 329200 – Lawns and Grasses

C. Section 329300 – Woody and Herbaceous Plant Installation

1.03 QUALITY ASSURANCE

A. Qualifications

1. The contractor shall be a company specializing in landscape construction with a minimum of five (5) years of experience on comparable projects.

B. Code and Standards Compliance

1. All materials and work shall comply with applicable codes, standards and with the requirements of local agencies. The Contractor shall obtain all permits required.

1.04 SUBMITTALS

A. Topsoil Data

1. Provide, to the Landscape Architect, the location(s) and name(s) of topsoil sources from which supplemental topsoil is to be obtained for the project, approximate quantities obtained at each site, depth at which soil was taken and indicate whether crops had grown on site(s).

B. Other Samples

1. The following materials shall be submitted to the Architect for approval prior to delivery to the site.
 - a. Submit 1 quart samples of imported topsoil, sand, and organic compost to be used.
 - b. Submit manufacturer's data for fertilizers and amendments recommended by the soil testing analysis.

1.05 PRODUCT DELIVERY, STORAGE AND HANDLING

A. Topsoil and Organic Compost

1. Coordinate and deliver topsoil and organic compost to pre-approved staging areas. Inform the Architect of all delivery schedules, twenty-four (24) hours in advance of delivery.
2. All deliveries of topsoil and organic compost which in any way fails to meet the requirements of these specifications will be rejected, and the Contractor shall immediately remove such rejected material from the premises and supply suitable material in its place.
3. No deliveries will be permitted when weather conditions are unsatisfactory, or if the approved staging area is not in a satisfactory condition to receive material. No frozen material will be accepted. Do not deliver or handle soil in wet, muddy or frozen conditions. Protect stockpiles from winds and disturbance with landscape fabric or other material.
4. Trucks making deliveries shall use routes as directed to avoid damage to property. The Contractor shall deliver material in dump trucks having pneumatic tires and shall be unloaded from the trucks where directed. All material that is deposited other than in the place designated shall be moved.

B. Other Materials

1. Handle and store all other materials according to manufacturer's recommendations.

1.06 JOB CONDITIONS

A. General

1. Prior to beginning work, the Contractor shall examine and verify the acceptability of the job site and notify the Landscape Architect of unsatisfactory conditions. The Contractor shall not proceed with the work until unsatisfactory conditions have been corrected or resolved.
2. Where soil preparation occurs in close proximity to other site improvements, adequate protection shall be given to all features prior to commencing work. Any items damaged during soil preparation operations shall be promptly repaired to their original condition at no additional cost to the Owner.

B. Utilities

1. Have all underground utilities located by servicing agencies. In the vicinity of utilities, hand excavate to minimize the possibility of damage to underground utilities.

C. Excavation

1. When conditions detrimental to plant growth are encountered such as limestone, rubble fill, adverse drainage conditions, or obstruction, notify the Landscape Architect prior to placement of any soil.

PART 2 - PRODUCTS

2.01 MATERIALS

A. Subsoil Fill

1. Where site conditions require a layer of fill below the specified bed depth, provide a clean, debris-free mineral material with a brown sandy clay content and granular material with no stones measuring larger than one inch in diameter. The pH should range between 5.5 to 6.5 with no limestone present. Gray clay soils shall not be accepted.

B. Topsoil

1. Utilize on-site topsoil to complete work. Provide imported topsoil material as needed to supplement on-site topsoil.
2. Topsoil, whether on site or imported, shall be uniformly pulverized and blended.
3. Topsoil shall be a sandy loam mineral soil, uniform in color and texture; corresponding to native soils; containing no grass roots, sod, weeds, rocks, stiff clay, clods, or any other substance undesirable to plant growth. The soil shall be loose, friable, and of good tilth. The pH shall range between 5.5 to 6.5.
4. Nutrient data as follows. All soil sampling and testing shall comply with procedures in the USDA Ag. Handbook 60: Diagnosis and Improvement of Saline and Alkali Soils.

Phosphorus	Min. 75 lbs./ac.
Potassium	Min. 300 lbs./ac.
Calcium	Min. 1,500 ppm
Cation Exchange Capacity	Min. 20 meq/100g
Soluble Salt	Max. 1,000 ppm

- a. Organic content shall not be less than 3 percent and not greater than 5 percent determined by loss of ignition.
- b. Gradation:

<u>Sieve Designation</u>	<u>Percent Passing</u>
No. 4 (4.76 mm)	100
No. 10 (2.00 mm)	95 - 100
No. 18 (1.00 mm)	90 - 100
No. 35 (500 micron)	65 - 100
No. 60 (250 micron)	0 - 50
No. 140 (105 micron)	0 -20
No. 270 (53 micron)	0 -10

- c. Textural Grades:

Fine gravel, coarse sand, medium sand	20 - 40 %
Silt	25 - 60 %
Clay	5 - 20 %

Clay content shall be determined by Bouyoucous hydrometer Test.

- C. Sand shall be clean, sharp, coarse sand passing 1/4" mesh screen and free of foreign and organic matter. The pH shall range between 5.5 to 6.5.
- D. Organic Compost shall be thoroughly decomposed organic waste produced at an IEPA registered composting facility. The compost shall have no glass or metal shards present. Any plastic or other man made material shall be no larger than 1/4 in. and sieved out to be less than one percent of the total dry weight. A copy of the compost test results complying with IEPA standards for General Use Compost and certification of IEPA registration shall be provided to the Engineer with each shipment of compost. Compost shall be capable of supporting and germinating vegetation.

E. pH Adjustment

Soil pH adjustments will be made based on soil test lab recommendations.

- 1. Limestone: Calcium carbonate (ground limestone) with 50% passing a No. 200 mesh sieve, 90% passing a No. 100 mesh sieve and 100% passing a No.10 mesh sieve. Total carbonates shall not be less than 80%.
- 2. Sulfur: Granular sulfur.

PART 3 - EXECUTION

3.01 PREPARATION

Protection of Site Improvements: Protect all existing site improvements during excavation. If any existing improvements are damaged, replace or make arrangements with the proper authorities for repair.

3.02 PERFORMANCE

- A. Permanent Grass and Sod Bed Preparation: Place topsoil to the required depths per the plans. Distribute required soil amendments evenly and thoroughly per soil test results and incorporate fertilizer into the top 2 inches of dry topsoil as described in Section 329200 – Lawns and Grasses.
- B. Landscape Bed Preparation: Prior to installation of any shrubs and herbaceous material, incorporate 2 inches minimum of organic compost into the top 10 inches of topsoil by disking or tilling.
- C. Landscape Planter Preparation: Prior to the installation of any shrubs and herbaceous material, place the soil mixture consisting of 2 parts topsoil and 1 part sand to the required depths per the plans. The sand, in the amount required to produce an acceptable planter soil blend, shall be mechanically blended during the pulverization process prior to placement into the planter. The planter soil mixture shall be placed in two lifts. The first lift shall be 2/3 of the planter soil depth. After placing each lift, moisten the surface at a rate sufficient to hydraulically settle the soil. Allow the water to thoroughly percolate through the soil before placing the next lift.

D. Landscape Excavation and Backfill

1. Planting pits shall be round, with vertical sides and flat bottoms, and sized in accordance with the dimensions shown on the drawings.
2. If rotating augers or other mechanical diggers are used to excavate holes, the vertical sides of the pits shall be scarified, fractured, or otherwise broken down to eliminate impervious surfaces.
3. Loosen or scarify soil in the bottom of all plant pits to a depth of four (4") inches.
4. Existing native soils are to be used as backfill during plant installation. The existing native topsoil and sub-soils used for herbaceous or shrub backfill shall meet the requirements as specified within this section. Landscape beds shall be excavated to proper depths and amended as specified. Landscape beds shall be brought to a smooth and even surface conforming to established grades.
5. Where pavement and other structures have been removed, bring planting bed to sub-grade with suitable subgrade fill.

3.03 CLEANUP AND PROTECTION

A. Clean Up

1. Debris and excess material shall be removed from the site immediately after installation.
2. When an excavation or backfill area is completed, completely clean up all soil piles and sweep all walks and drives.
3. All existing sidewalks and driveways providing access to on-site buildings shall be kept clean and free of obstructions. Other paved areas shall be cleaned when work in adjacent areas is completed

B. Protection

1. Protect all completed work from disturbance from operations of other trades and trespassers. Replace damaged work to specified conditions at no additional cost to the owner.

3.04 ACCEPTANCE

A. Completion of the Work

1. Upon completion of work, the Contractor shall notify the Landscape Architect and the Owner at least ten (10) days prior to requested date of substantial completion of all or portions of the work. Landscape Architect will review all of the work and prepare a punch list of work not installed or not installed in conformance with the contract documents. All work in the punch list must be completed within five (5) working days from date of issue. Where work does not comply with requirements, replace rejected work and continue specified protection and maintenance until reviewed by Landscape Architect and found to be acceptable.

B. Certificate of Substantial Completion

1. Certificate of substantial completion will be issued for acceptable work at sole discretion of the Landscape Architect. If punch list items are issued with the certificate, they must be corrected within five (5) working days. If items are not corrected within five (5) working days than the certificate of substantial completion will be revoked and reissued when the punch list items are corrected.

C. Final Acceptance

1. After the certificate of substantial completion the Landscape Architect and the Owner will review the work for final acceptance. Upon satisfactory completion of repairs and / or replacements the Landscape Architect will certify, in writing, final acceptance of the work, which will serve as evidence that Contractor's obligations have been met.

END OF SECTION 329100